



Manual



LITHIUM BATTERY
SB12V160E-ZC

13.2V/160Ah
(2.1kW LiFePO4)

User Manual SB12V160E-ZC Lithium Iron Phosphate battery

Dear customer,

This manual contains all the information necessary to install, use and maintain the Super B SB12V160E-ZC Lithium Iron Phosphate Battery. We kindly ask you to read this manual carefully before using the product. In this manual, the SB12V160E-ZC battery will be referred to as: the Li-Ion battery.

This manual is meant for the installer and the user of the Li-Ion battery. Only qualified, certified personnel may install and perform maintenance on the Li-Ion battery. Please consult the index at the start of this manual to locate information relevant to you.

This is the original manual, keep it in a safe location!

Copyright© Super B b.v. All rights reserved. Licensed software products are owned by Super B or its subsidiaries or suppliers, and are protected by national copyright laws and international treaty provisions. Super B products are covered by Dutch and foreign patents, issued and pending. Information in this publication supersedes that in all previously published material. Specifications and price change privileges reserved. Super B is a registered trademark of Super B b.v.

For more information, or to order documents, contact:

Super B b.v.
Diamantstraat 1e
7554 TA Hengelo (Ov)
The Netherlands

Tel: +31(0)748200010
Fax: +31(0)748200011
E-mail: info@super-b.com
www: www.super-b.com

Table of content

1. Introduction	5
1.1. Product description	5
1.2. Glossary of Terminology	5
1.3. Used symbols	6
2. Product specifications	6
2.1. Product features	6
2.2. General product specifications	6
2.3. Technical specifications	7
2.3.1. Battery designation	7
2.3.2. Electrical properties	7
2.3.3. Dimensions	8
2.4. Environmental conditions	8
2.5. Required tools	9
2.6. Components	9
2.6.1. List of components	9
2.7. Connections, indicators and battery controls	10
2.7.1. Con1 (I/O Connection 4)	11
2.7.2. Con2 (I/O connection 7)	11
2.8. Peripheral equipment	11
2.8.1. Obligatory	11
2.8.2. Optional	12
3. Safety guidelines and measures	12
3.1. General	12
3.2. Installation	12
3.3. Use	13
3.4. Disposal	13
3.5. Safety symbols and markings on product	13
4. Installation	14
4.1. General information	14
4.2. Unpacking	14
4.3. Preparing the battery for use	14
4.3.1. Placement of the battery	14
4.3.2. Placement and removal of a fuse	15
4.4. Connection wires	16
4.5. Installing the battery in an electrical circuit	16
4.5.1. Installing a Battery Disconnect device,	16
4.5.2. Connecting CANopen interface	17
4.5.3. Connecting the battery to the load	19

4.5.4.	Connecting a charger to the battery	21
4.5.5.	Disconnecting a battery	21
4.5.6.	More configuration options	22
5.	Battery use	25
5.1.	General information	25
5.2.	Charging	25
5.2.1.	Charging rate	25
5.2.2.	Charging method	25
5.2.3.	Battery balancing	27
5.2.4.	Serial String balancing	28
5.2.5.	Determining the battery's state of charge (SoC)	28
5.3.	Battery use	29
5.3.1.	Battery fault condition	29
5.4.	Battery Monitoring Software	29
5.4.1.	Continuous Battery Monitoring	30
5.4.2.	Battery History Recording	31
6.	Inspection, cleaning and maintenance	31
6.1.	General information	31
6.2.	Inspection	31
6.3.	Cleaning	32
6.4.	Maintenance	32
7.	Storage	32
8.	Transportation	32
8.1	General	32
9.	Disposal and recycling	33
9.1.	General information	33
10.	Troubleshooting	34
11.	Warranty and liability	36
Appendix I	Declaration of Conformity	38
Appendix II	Certificate of Compliance	39
Appendix III	Performance Graphs	40
Appendix IV	Conductor requirements	42

1. Introduction

1.1. Product description

The SB12V160E-ZC is a Lithium Iron Phosphate rechargeable battery. Potential applications of this battery include: off grid power supply, marine power supply, medium for (renewable) energy storage (traction) battery for vehicles. The boundaries of its use, as described in this manual should always be upheld. The Li-Ion battery may not be used in medical or in aviation related applications. The Li-Ion battery may not be used for any purposes other than described in this manual. Using the battery for any other purpose will be considered improper use and will void the warranty of the product. Super B b.v. cannot be held responsible for any damage caused by improper, incorrect or unwise use of the product. Read and understand this manual completely before using the product.

Super B provides a CE declaration of conformity (appendix I) and a Certificate of Compliance (appendix II) for the product. In accordance with CE guidelines, a design and manufacturing schedule is available. A Material Safety Data Sheet is also available.

The SB12V160E-ZC complies with the following council directives:

- 2006/66/EC on Environmental EU Compliance
- 2004/108/EC (December 15, 2004) on Electromagnetic Compatibility

The SB12V160E-ZC complies with the following standards:

- EMC: Emission - EN61000-6-3 (2007) +A1 (2001); Immunity - EN6100-6-2 (2005) + AC (2005)
- IEC 62133, Safety IEC Compliance
- IEC 61960(ed2.0), Performance IEC Compliance
- IEC 62281, Transportation IEC Compliance

During the use of the product, user safety should always be ensured, so installers, users, service personnel and third parties can safely use the product. The user must always have access to this manual; keep it in a safe accessible location.

1.2. Glossary of Terminology

Endurance Life-cycle:	The products maximum lifespan, achieved by adhering to the guidelines presented in this manual.
Charge cycle:	A period of use from fully charged, to fully discharged, and fully recharged again.
BCI:	Battery Communication Interface
SoC:	State of charge

1.3. Used symbols

The following icons will be used throughout the manual:

- ⚠ Warning!** A warning indicates severe damage to the user and/or product may occur when a procedure is not carried out as described.
- ⚠ Caution!** A caution sign indicates problems may occur if a procedure is not carried out as described. It may also serve as a reminder to the user.

2. Product specifications

2.1. Product features

- Traction battery
- Lithium Iron Phosphate (LiFePO₄)
 - Safe lithium technology
 - Superior abuse tolerance
- Integrated BMS (Batterie-Managementsystem)
- Glass fiber reinforced plastic (GRFP) Casing, Aluminum / PE sandwich side panels
- Terminals for 2 x 95mm² wire connection per terminal
- Integrated fuse, 32V / 500A
- 3C continuous discharge (480A)
- CANopen interface for battery monitoring
- Battery monitoring / History Storage
- Adaptive cell balancing
- Serial string equalization
- Serial string connection up to 1150V DC
- Battery Disconnect device, Relay, Latching relay (bi-stable)
- Battery Disconnect device, CAN Controlled

2.2. General product specifications

Product name:	SB12V160E-ZC
Producer:	Super B b.v.
Battery type:	Lithium Iron Phosphate (LiFePO ₄)
Product Lifespan:	+/-5 to 10 years or 1000-2000 cycles at 1C charge / discharge or 8000 cycles at C3 charge / discharge*

*The lifespan value given above is an indication. Battery lifespan depends strongly on the applied charging and discharging loads. For more information on the lifespan of the battery, appendix II may be consulted.

2.3. Technical specifications

Mass:	26.75 kg +/- 0.250 kg
Ingress protection rating	IP53

2.3.1. Battery designation

Battery designation:	4IFP227/415/315
----------------------	-----------------

2.3.2. Electrical properties

Nominal voltage	13.2V DC
Charge method	CCCV
Maximum end of charge voltage	14.6V
End of charge voltage for endurance (cycle life)	14.4V DC
Charge current	160A (1C)
Charge current for endurance (cycle life)	52.8A (C/3)
End-of-discharge voltage	8V DC
End-of-discharge voltage for endurance (cycle life)	10V DC
Maximum serial string connection voltage	1150V DC
Discharge current	480A (3C)
Discharge current for endurance (cycle life)	52.8A (C/3)
Discharge pulse current (10 seconds) (external fuse)	1280A (8C)
Discharge pulse current (60 second) (external fuse)	800A (5C)
Discharge performance at 20 °C (rated capacity)	160Ah / 2112Wh
Discharge performance at -20 °C (capacity)	104Ah / 1372.8Wh
High rate discharge performance at 20 °C (capacity)	144Ah / 1900,8Wh
Short-circuit protection (fuse):	500A
Self-discharge:	± 10% per year

More information on the battery's discharge performance and capacity may be found in appendix III.

2.3.3. Dimensions

Height (H):	313.00 / 314.00 mm
Width (W):	413.50 / 414.50 mm
Thickness (T):	225.00 / 226.00 mm

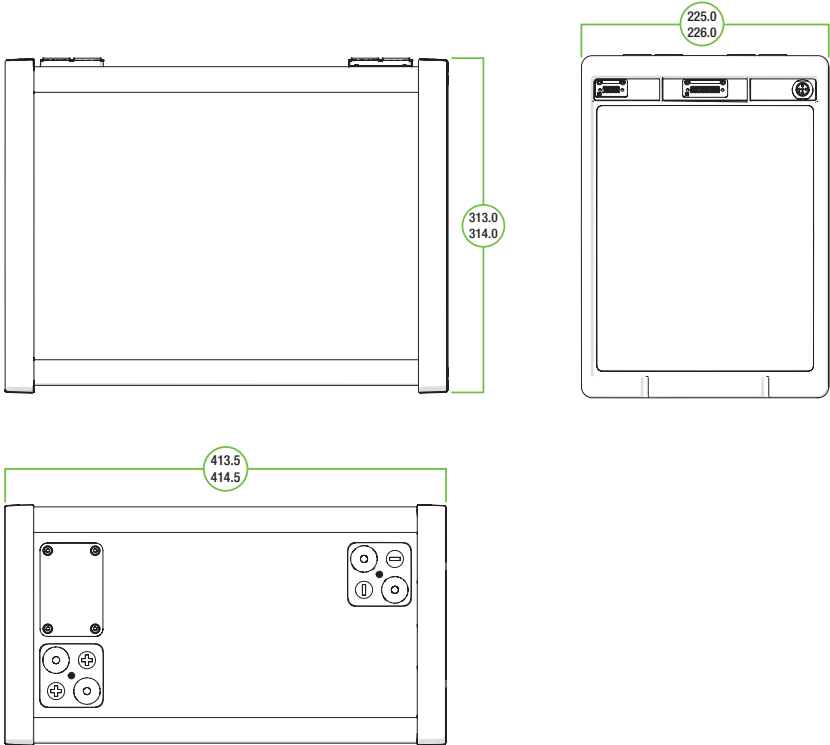

2.4. Environmental conditions

- ⚠ Warning!** The Li-Ion Battery may only be used in conditions specified in this manual. Exposing the battery to conditions outside the specified boundaries may lead to serious damage to the product and/or the user.

Use the battery in a dry, clean, dust free, well ventilated space. Do not expose the battery to fire or water or solvents.

When the batteries are placed in an enclosed environment without air circulation, it's advised to provide 2 ventilation holes of 100mm x 100mm each. This helps to prevent the heat built-up.

Operating temperature range (Charge) (1)	-20°C to +60°C
Operating temperature range (Discharge)	-20°C to +60°C
Storage temperature range	-20°C to +60°C
Relative humidity	Between 5 and 85 %, non-condensing
Placement angle (continuously)	90 degrees
Vibrations and shocks	As described in UN38.3 and IEC 6228

(1) Fast charging at temperatures lower than 0°C or higher than 45°C can reduce battery life. For maximum battery life a charge temperature range of 0°C to +45°C is advised. Consult your reseller or Super B for charge rate recommendations for your application.

2.5. Required tools

- M13 Hexagon socket wrench
- Fuse TORX key

2.6. Components

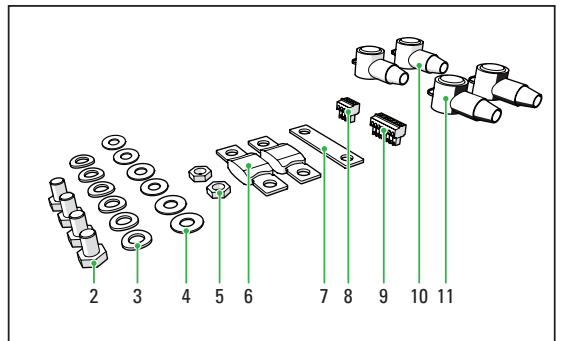
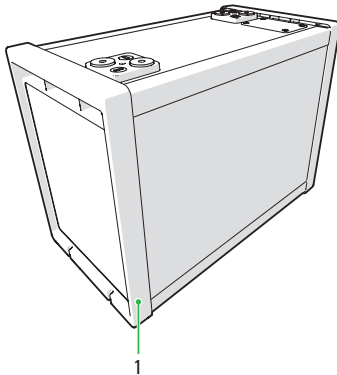

2.6.1. List of components

1. (1) Super B SB12V160E-ZC Battery
2. (4x) M8 Bolt
3. (6x) M8 Spring washer
4. (6x) M8 Plain washer
5. (2x) M8 Nut
6. (2x) Mega Fuse 32V/500A
7. (1x) Dummy Fuse
8. (1x) Phoenix plug 4
9. (1x) Phoenix plug 7
10. (2x) Terminal cover, Red
11. (2x) Terminal cover, Black

2.7. Connections, indicators and battery controls

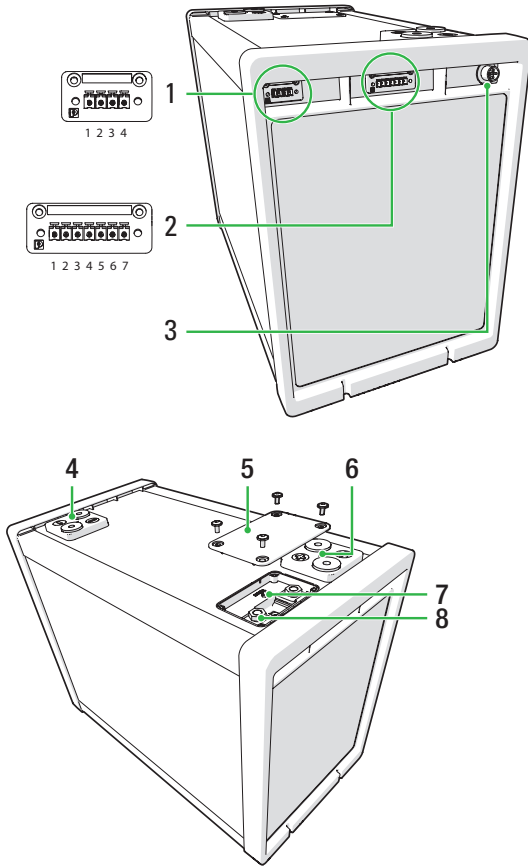

1. Con 1 (I/O Connection 4; Phoenix FRONT-MC 1,5/4-STF-3,81 1850877)
2. Con 2 (I/O Connection 7; Phoenix FRONT-MC 1,5/7-STF-3,81 1850903)
3. Con 3 (CANopen; 5-pin "micro" style connector)
4. Terminal - (2x 95mm² wire connection)
5. Fuse cover
6. Terminal + (2x 95mm² wire connection)
7. Reset button
8. Fuse connections

2.7.1. Con1 (I/O Connection 4)

Pin1:	+, OFF
Pin2:	-, ON
Pin3:	-, OFF
Pin4:	+, ON

2.7.2. Con2 (I/O connection 7)

Pin1:	V+ max 30 Volt
Pin2:	AN_SOC (Analogue state of charge)
Pin3:	Nc (Not connected)
Pin4:	Rc, (Relay common contact)
Pin5:	Rnc, (Relay normaly close contact)
Pin6:	Rno, (Relay normaly open contact)
Pin7:	GND, (Ground)

2.8. Peripheral equipment

2.8.1. Obligatory

In order for the Li-Ion battery to be used safely, an approved external switch off device must be installed. This should either be a relay or latching relay (bi-stable) controlled by the battery's BMS or a relay or latching relay controlled by a remote switch (CAN controlled). (see paragraph 4.4) Failure to install an external switch off device will void the warranty of the Li-Ion battery.

2.8.2. Optional

The Li-Ion battery can be used in combination with a number of (Super B) products:

Article name	Article code
SB-LIR250 (relay)	9586 100 3106 0
SB-V23130C2021A412-TE (latching relay)	9586 100 3108 0
SB Terminator Resistor Female	9586 100 4001 0
SB Terminator Resistor Male	9586 100 4002 0
SB CAN Male-female Cable 0.6m	9586 100 3001 0
SB CAN Male-female Cable 1m	9586 100 3002 0
SB CAN Male-female Cable 2m	9586 100 3003 0
SB CAN Male-female Cable 5m	9586 100 3004 0
SB CAN Male-female Cable 10m	9586 100 3005 0
SB T-splitter	9586 100 3006 0
SB BiB LV48V350A 8718531360914	9586 100 3008 0
SB USB to Can	9586 100 3201 0
SB Monitor Software	9586 100 3201 0
Mounting bracket ZC casing	9586 300 0009 0

3. Safety guidelines and measures

3.1. General

- ⚠ **Warning!** Keep the battery away from fire, excessive heat, water, dust and contamination.
- ⚠ **Corrosive!** Do not touch the battery's electrolyte after leakage. If contact occurs, flush with (lukewarm) water and seek medical assistance immediately.
- ⚠ **Warning!** Do not disassemble, crush, or puncture the battery.
- ⚠ **Warning!** Keep the Li-Ion battery away from children.
- ⚠ **Warning!** Never touch the battery contacts or allow (conductive) objects to touch the contacts.

3.2. Installation

- ⚠ **Warning!** Never use the Li-Ion battery without a properly installed Battery Disconnect device, controlled by either the Li-Ion battery or a Battery communication Interface (SB BCI-C1).

3.3. Use

- ⚠ **Warning!** Do not overcharge the Li-Ion battery.
- ⚠ **Warning!** Never short circuit the battery.

3.4. Disposal



Dispose of the battery in accordance with local, state and federal laws and regulations. Batteries may be returned to the manufacturer. Do not mix with other (industrial) waste.

3.5. Safety symbols and markings on product

A number of safety symbols and markings can be found on the product. These markings are displayed below. Never remove these markings!

Symbol	Description
	Keep the Li-Ion battery upright. Never tilt the battery more than 90 degrees.
	Dispose of the Li-Ion battery in accordance with local, state and federal laws and regulations. Batteries may be returned to the manufacturer. Do not mix with other (industrial) waste.
	This product, or sections of this product can be recycled.

4. Installation

4.1. General information

- ⚠ **Warning!** Do not disassemble, crush, or puncture the Li-Ion battery.
- ⚠ **Warning!** Never install or use a damaged battery.

When connecting several batteries in series or parallel, always use batteries of the same brand, type, age, capacity and state of charge.

The Li-Ion battery is one on one interchangeable with AGM/GEL lead acid batteries.

4.2. Unpacking

Check the battery for damage after unpacking. If the battery is damaged, contact your reseller or Super B. Do not install or use the battery if it is damaged!

4.3. Preparing the battery for use

4.3.1. Placement of the battery

Before it is used, the Li-Ion battery must be positioned in such a way that it will not move around in its compartment during use. If necessary, the Li-Ion battery may be fixed in place by means of Super B mounting brackets. The brackets can be screwed in place by means of bolts or screws (See Figure 1).

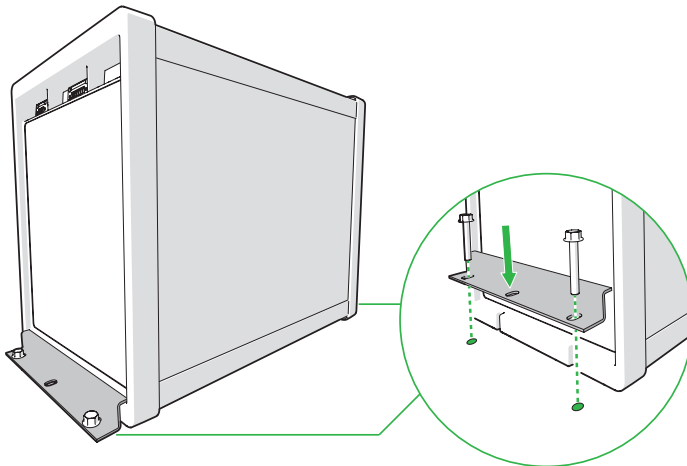

Figure 1. Installing the Li-Ion battery using the Super B mounting brackets

4.3.2. Placement and removal of a fuse

Before the Li-Ion battery can be used, either an internal fuse or a dummy fuse needs to be installed into it. Two 48V/500A Mega fuses and one dummy fuse are supplied with the product. Other fuses may only be used in the product when they are approved by Super B for this application.

- Use an internal (Mega) fuse if a single battery is installed, if two batteries are installed in series or if a number of batteries are installed parallel to one another. The discharge current may not exceed 500A and the maximum voltage may not exceed 48V.
- Use a dummy fuse if three or more batteries are placed in series, if maximum discharge current exceeds 500A or if the maximum voltage exceeds 48V.

⚠ Warning! Always use an external fuse with the appropriate value when a dummy fuse is used.

Use the following steps to place a Mega Fuse or a dummy fuse in the battery (Figure 2):

1. Turn off any device or charger the battery is connected to.
2. Turn off the external BMS (latching) relay or external BMS cut-off switch.
3. Disconnect the negative wire from the - pole of the battery (see paragraph 4.5.5. for the details).
4. Disconnect the positive wire from the + pole of the battery.
5. Unscrew the fuse cap using the fuse TORX key.
6. Unscrew the fuse contacts using the M13 wrench.
7. Press the reset button for 5 seconds.
8. Place the (new) fuse between the contacts, place washers and spring washers and tighten the fuse contact points to 13Nm.
9. Fasten the fuse cap.
10. Proceed to the next paragraph to read the instructions on installing the battery in an electrical circuit.

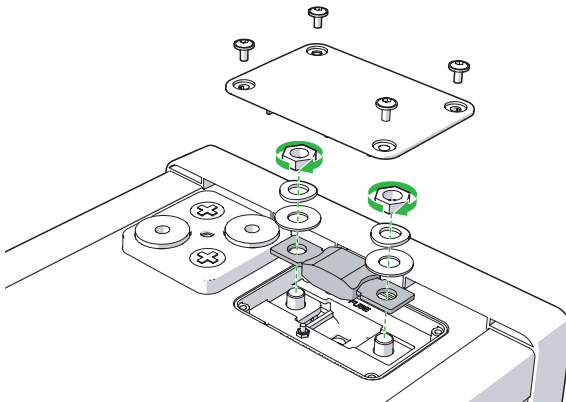

Figure 2. Install a fuse

4.4. Connection wires

Use appropriate wire for the connection wires to ensure no overheating or unnecessary losses occur. Consult the SAE-J378 or ISO 10133:2012 standards to determine the appropriate wire properties. Use appropriate fuses matching the wires and load. See appendix IV for more details.

4.5. Installing the battery in an electrical circuit

- ⚠ **Warning!** Never use the Li-Ion battery without a properly installed Battery Disconnect device (relay or latching relay) controlled by either the Li-Ion battery or a Battery communication Interface (SB BCI-C1)
- ⚠ **Warning!** Install the appropriate fuse before connecting the battery to other devices (see paragraph 4.3.2). Use an appropriate external fuse if a dummy fuse is used.

4.5.1. Installing a Battery Disconnect device,

An external Battery Disconnect device can be installed between the + or - terminal of the battery and the load. This Battery Disconnect device can be controlled in one of two ways:

- Connect a latching relay or a normal relay to the battery's internal driver.
- Connect a latching relay or a normal relay to a remote switch. If applicable, consult the manual of the remote switch for the appropriate installation instructions.

Connecting a latching relay to the battery:

1. When using a latching relay, connect it to Con 1 (I/O Connection 4) as displayed in Figure 3. The internal driver controls both high and low side.

The output of Con 1 can be found in Table 1.

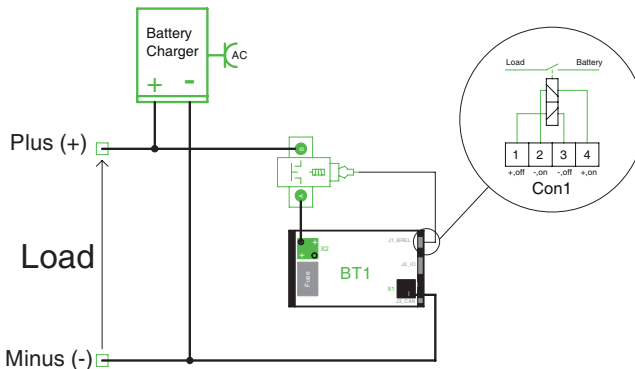

Figure 3. Connect a latching relay as Battery Disconnect device

	Con 1 output (12V DC)
Continuous	2,7A
100ms pulse	15 A

Table 1.

Connecting a normal relay as Battery Disconnect device:

Warning! Always connect the relay between the + or - terminal of the battery and the load.

- When using a normal relay, connect it to Con 2 (I/O Connection 7), Pin 4 (Rc) and Pin 5 (Rnc) as displayed in Figure 4.

	Pin 4
V max	250V DC
A max	5A

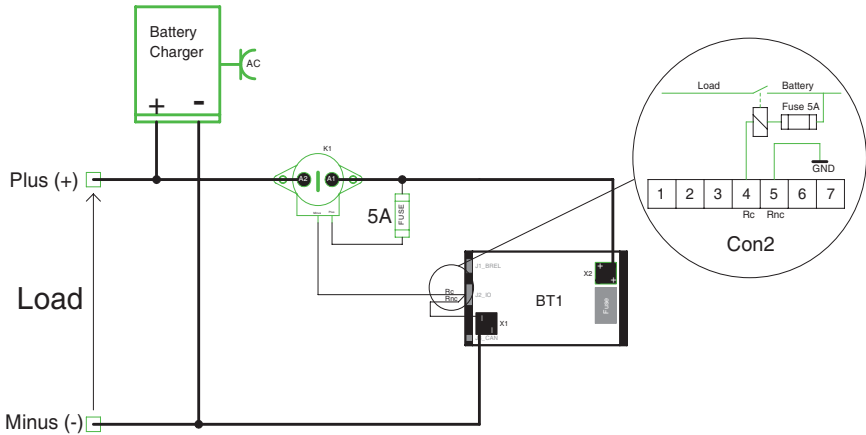

Figure 4. Connect a normal relay as Battery Disconnect device.

4.5.2. Connecting CANopen interface

To use the battery monitoring software, the CAN bus of the Li-Ion battery (CON 3) needs to be connected to the computer on which the monitoring software is installed.

More information on the CANopen bus can be found at the CiA website: www.can-cia.org.

The required documentation can be found in the following CiA documents: (or in a future version of these documents.)

- CiA 301
- CiA 303_1 V1.8.0; Sections 5 (AC and DC parameters) and 7.2: (5-pin "micro" style connector)

CAN Bus network topology

The CAN Bus must be used in a bus network topology (see Figure 5 and Figure 6). Do not use a ring- or a star topology. The CAN specifications restrict the Bus length/Bus speed. Displayed in Table 2 is an overview of these restrictions.

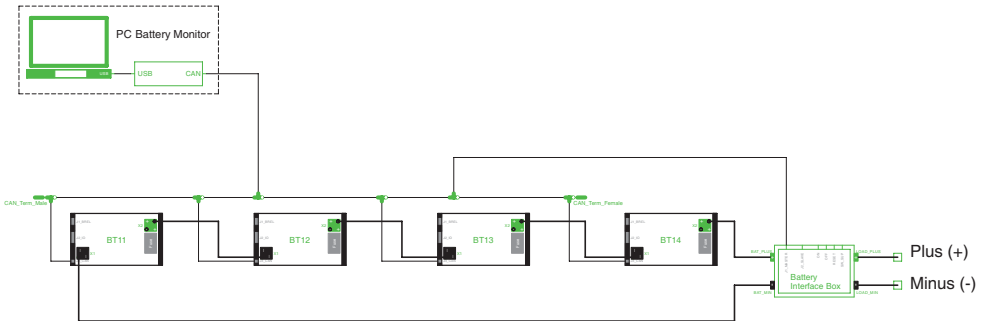

Figure 5. CAN Bus network topology

Bit rate	Bus length (L)	Max. stub length (S)	Accumulated stub length
250 kbit/s	250 m	11 m	55 m

Table 2. CAN bus speed

The default speed of the Can BUS is 250 kbit/s.

A high speed bus requires termination at the two ends of the bus. The CAN to USB converter can either be connected at one end of the bus (with termination) or in the middle of the bus with no termination; termination should then be placed at the endnodes of the bus line.

Termination Resistors

Use termination resistors at the end nodes to impede reflections on the line. The value of this resistor should be +/- 120 ohms. More information on termination resistors can be found in CiA document 303_1 V1.8.0, section 5.

CAN bus power

Due to the galvanic separation between the battery monitoring hardware and the battery, an external power supply is needed for the CAN bus. The CAN bus can be powered by either the SB-BCI. If the SB-BCI cannot be used, the CAN bus can be powered through Con 2 (I/O Connection 7). This situation may occur when a USB-to CAN interface is directly connected to the battery (Figure 6).

1. Connect Pin 1 of Con2 to the + terminal of the battery.
2. Connect Pin 7 of Con2 to the - terminal of the battery.

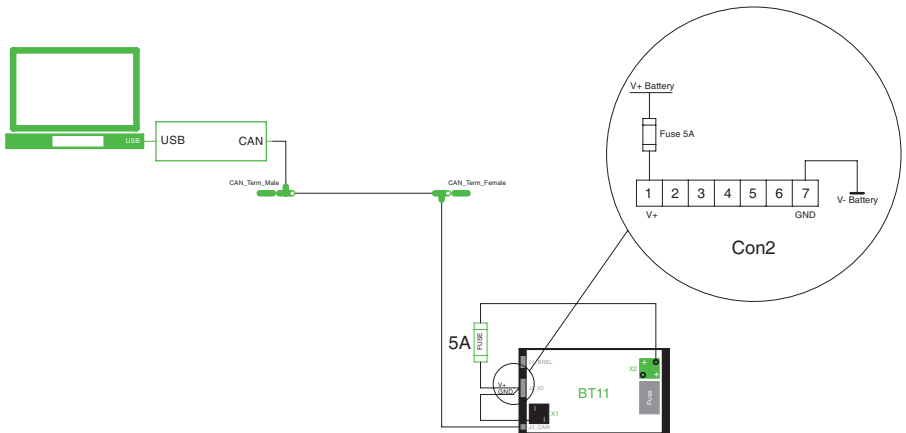

Figure 6. Use Con2 to power the CAN bus

4.5.3. Connecting the battery to the load

⚠ Warning! Ensure you have completed all the previous steps described in chapter 4 before connecting the battery to the load.

1. Slide the terminal covers over the connection wires.
2. Connect the + terminal of the battery to the - or A2 terminal of the relay (Figure 7).
3. Connect the load or charger to the + or A1 terminal of the relay.
4. Connect the - terminal of the battery. Do not connect the - terminal first as this may lead to short circuits (Figure 7).
5. Ensure both contacts are tightened to 20Nm.
6. Place the terminal covers over the terminals (Figure 8).

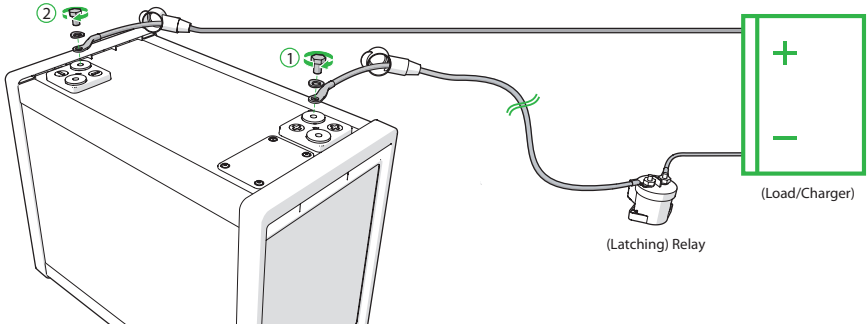

Figure 7. Connecting the battery to the load

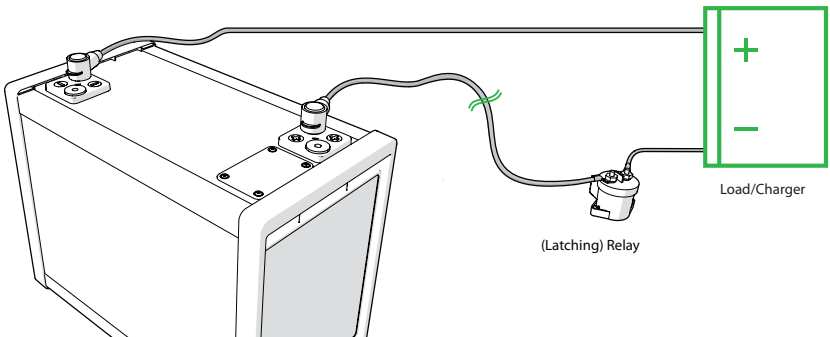

Figure 8. Securing the terminal covers

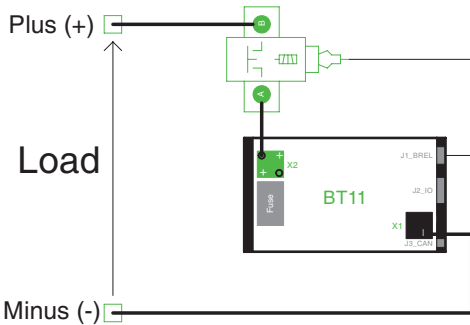

Figure 9. Connecting the battery to the load

4.5.4. Connecting a charger to the battery

⚠ Warning! Ensure you have completed all the previous steps described in chapter 4 before connecting the battery to the charger.

1. Connect the charger behind the Battery Disconnect device as displayed in Figure 10.
2. Disconnect the charger from the mains and the battery if it is not used for a long time.

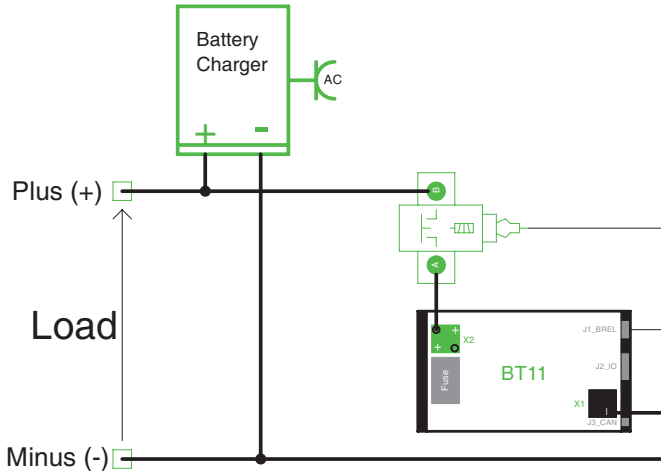

Figure 10. Connecting the charger

4.5.5. Disconnecting a battery

1. Turn off any device or charger the battery is connected to.
2. Turn off the external BMS (latching) relay or external BMS cut-off switch.
3. Disconnect the negative wire from the - terminal of the battery.
4. Disconnect the positive wire from the + terminal of the battery.

4.5.6. More configuration options

Other configurations to connect the battery are also possible: see Figure 11 - Figure 21.

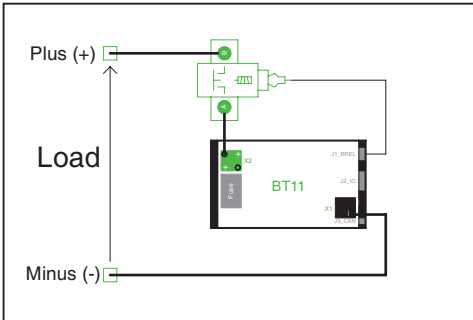

Figure 11. Example 1

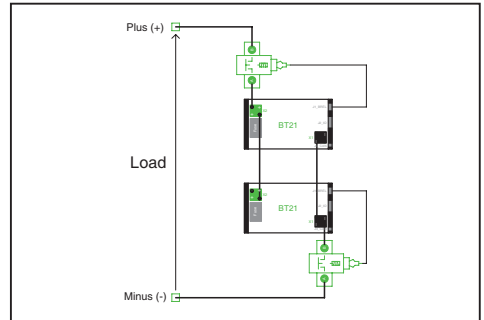

Figure 12. Example 2

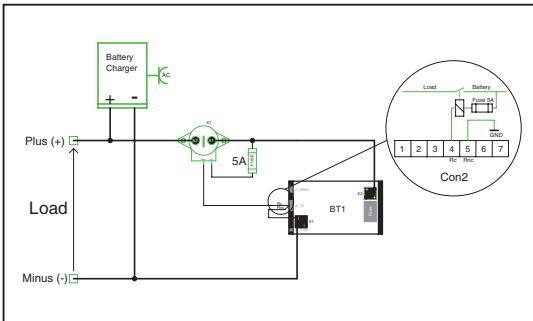

Figure 13. Example 3

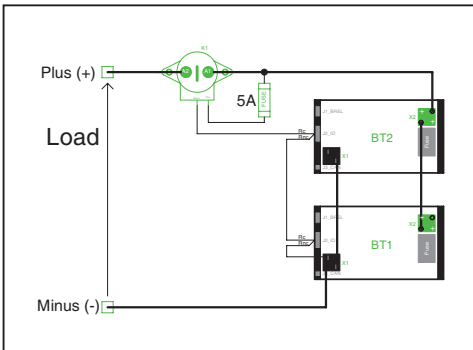

Figure 14. Example 4

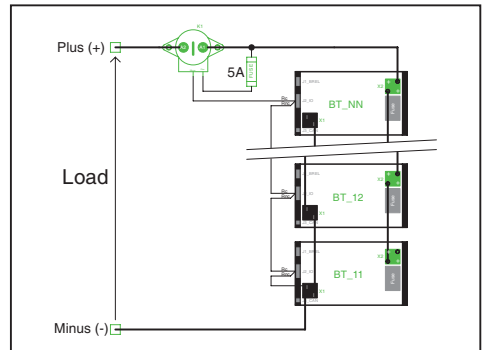

Figure 15. Example 5

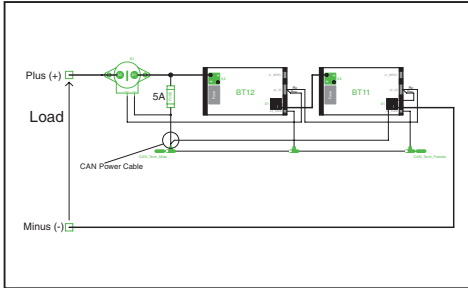

Figure 16. Example 6

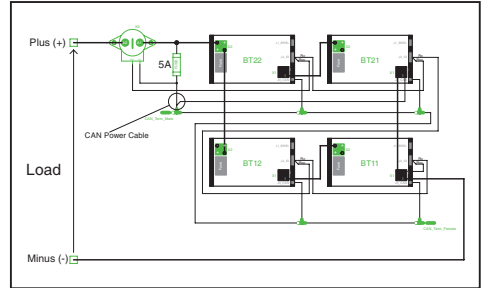

Figure 17. Example 7

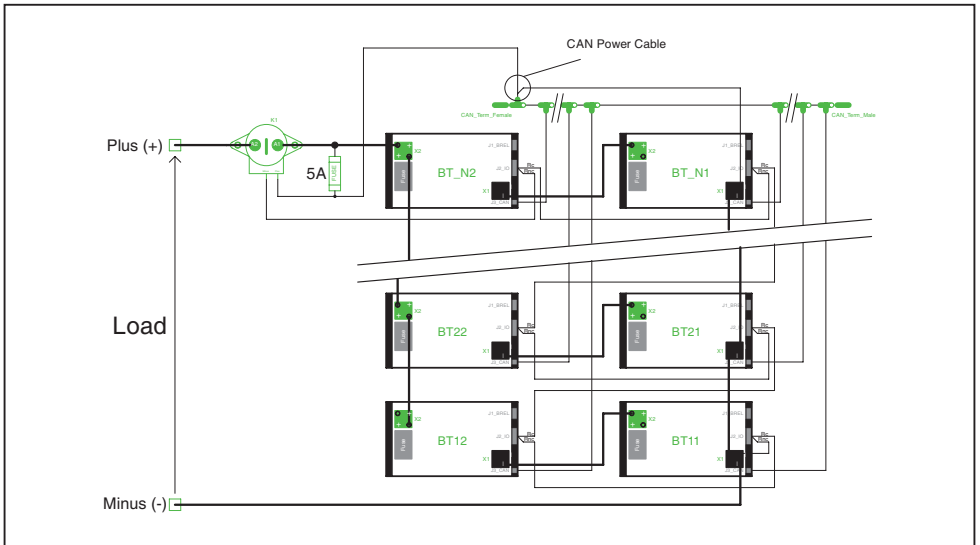

Figure 18. Example 8

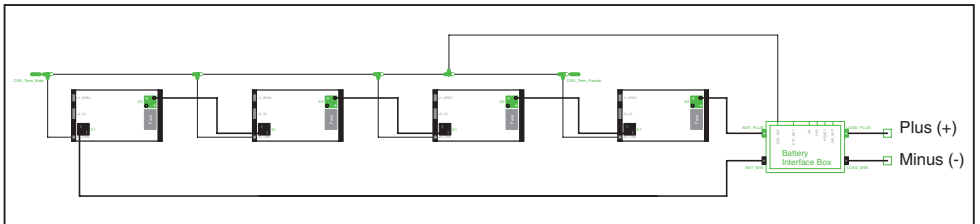

Figure 19. Example 9

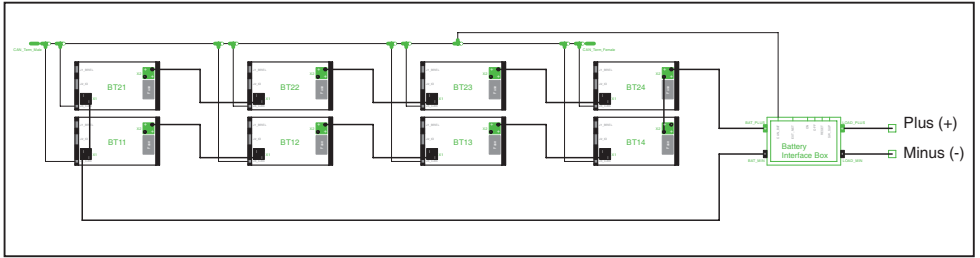

Figure 20. Example 10

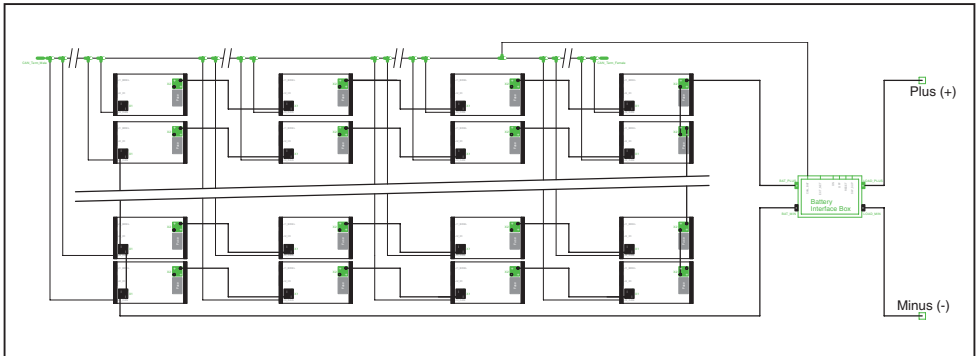

Figure 21. Example 11

5. Battery use

5.1. General information

⚠ Warning! Keep the Li-Ion battery away from children.

5.2. Charging

⚠ Warning! Never overcharge the Li-Ion battery, this will permanently damage the battery. Always use a charger which automatically halts the charging process when the battery is full.

⚠ Warning! Stop the charging process if the battery gets too hot during charging ($>55-60^{\circ}\text{C}$)

⚠ Warning! Never charge a battery with a charging current larger than 1C as this will damage the battery.

⚠ Caution! Disconnect the charger from the mains and the battery if it is not used for a long time.

⚠ Caution! To preserve the lifespan of the Li-Ion battery use a Super B charger or a charger approved by Super B. The use of other chargers, such as lead-acid chargers will shorten the lifespan of the Li-Ion battery. AGM / GEL chargers may be used if the charge voltages of the different charge states don't exceed the charge voltage limits of the battery.

1. Connect the charger to the battery as described in paragraph 4.5.3.
2. Charge the battery whenever the voltage of the battery drops below 10V or if the state of charge drops below 20% to preserve the lifespan of the battery.

5.2.1. Charging rate

Super B Lithium Iron Phosphate batteries can be charged in 1 hour. Displayed in Table 1 are the charge times for the Li-Ion battery at different charge currents. Always use the indicated charge current and end of charge voltage during charging.

Charging rate			
Parameter	Time	Charge current	End of charge voltage
Maximum	1 hour	1C	14,4V DC
Endurance lifecycle	3 hours	C3	14,4V DC

Table 3. Charging rates at different charge currents

5.2.2. Charging method

Super B recommends using this charging method since it aids in balancing the battery, prolonging the lifespan of the battery.

Charge Profile Super B Batteries

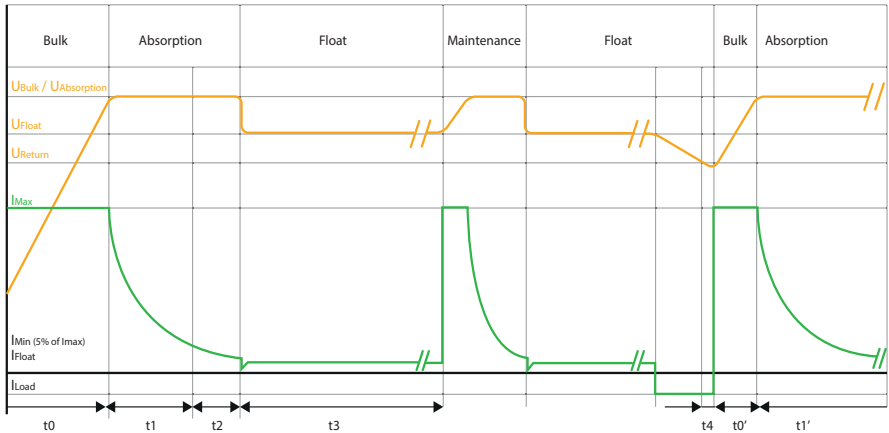

Figure 22. Charge curve

Bulk phase

In this phase the batteries are charged with a constant current up to the end of charge voltage (U_{bulk}). If U_{bulk} is reached the charger will automatically switch to absorption phase. The maximum charge current (I_{max}) for Super B batteries is 1C, however for endurance cycle life Super B suggests to limit the current to C3 (1C = nominal battery capacity, C3 = 1/3 of nominal capacity).

On some chargers the time t_0 can be programmed. The time t_0 depends on charger current and battery capacity. Super B suggests to set this time according the following formula: $t_0 = 2 * (BTCAP / ChCAP)$. Where BTCAP = 1C Battery Capacity and ChCAP = charger capacity. Example: Battery capacity 160Ah, Charger capacity 40A, t_0 set to $2 * (160Ah / 40A) = 8$ Hours.

Bulk Phase				
Parameter	Typical	Min	Max	Remark
U_{Bulk}	14,4V DC	14,3V DC	14,6V DC	-
I_{max}	C3	-	1C	-
t_0	$2 * (BTCAP / ChCAP)$	-	-	Optional

Table 4. Bulk Phase

Absorption phase

In this phase the charge voltage must be maintained at $U_{\text{Absorption}}$ to fully charge the battery. If the charger current drops below 5% (I_{min}) of the 1C current the absorption phase can be maintained for t_2 minutes, see Figure 22.

Absorption Phase				
Parameter	Typical	Min	Max	Remark
U_{Bulk}	14,4V DC	14,3V DC	14,6V DC	-
I_{min}	3% of 1C	-	5% of 1C	-
t_1	20 minutes	10 minutes	1 hour	-
t_2	10 minutes	5 minutes	30 minutes	-

Table 5. Absorption Phase

Float phase

In this phase the charge voltage is set to U_{Float} . If the battery voltage drops below U_{Return} for longer than t_4 seconds then the charging process has to be repeated.

Absorption Phase				
Parameter	Typical	Min	Max	Remark
U_{Bulk}	13,8V DC	13,7V DC	13,9V DC	-
U_{Float}	13,5V DC	13,4V DC	13,6V DC	-
t_4	60 sec	5 sec	-	-

Table 6. Float Phase

Optional maintenance phase

If supported by the charger, every t_3 hours the charger can do a maintenance charge to make sure that the batteries are kept fully charged.

Float Phase				
Parameter	Typical	Min	Max	Remark
t_3	300 hours	160 hours	400 hours	-

Table 7. Maintenance phase

5.2.3. Battery balancing

- The Li-Ion battery is automatically balanced when the charger goes to float mode and no current is drawn from the battery (see paragraph 5.2.2).

During the batteries lifespan, the cells within the battery may be unbalanced due to high discharge currents and short float charge periods. This may result in a loss of capacity and overcharged cells. Cells may be equalized by means of the following procedure:

1. Apply a constant voltage of 14.4 and a current of < 2A to manually equalize the Li-Ion battery.

5.2.4. Serial String balancing

The batteries in a battery bank are “balanced” when every battery in the bank possesses the same state of charge (SoC). SoC refers to the current remaining capacity of an individual battery relative to its maximum capacity as the battery charges and discharges. For example, a 160 Ah battery with 80 Ah of remaining capacity has a 50% state of charge (SoC).

All battery cells must be kept within an SoC range to avoid damage or lifetime degradation. The allowable SoC min and max levels vary from application to application. In applications where battery run time is of primary importance, all cells may operate between a min SoC of 10% and a max of 100% (or a fully charged state).

With a series/parallel array of cells, it is generally safe to assume the cells connected in parallel will auto-balance with respect to each other. That is, over time, the state of charge will automatically equalize between parallel connected cells as long as a conducting path exists between the cell terminals.

It is also safe to assume that the state of charge for cells connected in series will tend to diverge over time due to a number of factors. Gradual SoC changes may occur due to temperature gradients throughout the pack or differences in impedance, self-discharge rates or loading cell to cell. Although the battery pack charging and discharging currents tend to dwarf these battery to battery variations, the accumulated mismatch will grow unabated unless the batteries are periodically balanced. Compensating for gradual changes in SoC from battery to battery is the most basic reason for balancing series connected batteries. Typically, a passive balancing scheme is adequate to rebalance SoC in a stack of cells with closely matched capacities. Therefore CAN Balancing is required, see paragraph 4.5.6 for examples.

5.2.5. Determining the battery’s state of charge (SoC)

1. Connect Pin1 of Con2 to the battery’s + pole.
2. Connect Pin 7 of Con2 to ground.
3. Determine the voltage at Pin 2 of CON2 (see Figure 23).

The analog SoC output ranges from 0 to 10 volt, in which 0V corresponds with 0% SoC and 10V corresponds with 100% SoC.

The SoC is an indication. Charging currents smaller than 100mA are not used in the SoC calculation.

4. Take the battery through a complete charge cycle if the SoC indication does not provide an accurate representation of the SoC. This will recalibrate the SoC.

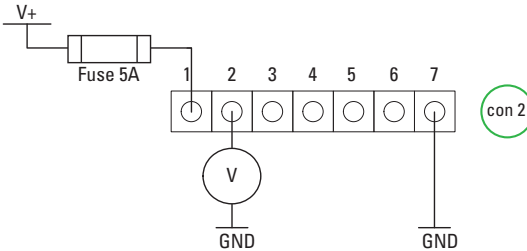

Figure 23. Determining the batteries SoC

5.3. Battery use

- ⚠ **Warning!** Do not short circuit the battery, this may lead to battery damage, explosion or fire.
- ⚠ **Warning!** Never touch the terminals of the battery.
- ⚠ **Warning!** Always use a Battery Disconnect device when connecting the battery to a load.
- ⚠ **Warning!** Always remain within the limits indicated in paragraph 2.3.2 during the use of the Li-Ion battery.

5.3.1. Battery fault condition

During battery use the external Battery Disconnect device may be triggered, disconnecting the battery from all loads and the charger. This shut off is the result of a fault condition. To identify and resolve this fault condition, chapter 10 may be consulted. The Battery Monitoring software may also be used to identify a fault condition. (see paragraph 5.4)

5.4. Battery Monitoring Software

Battery monitoring software offers the possibility to continuously monitor a number of battery properties through sensors within the Li-Ion battery. It also enables one to download a complete recording of the battery's properties over time (see paragraph 5.4.2).

The Battery Monitoring software and the hardware needed to connect the battery to the computer is not included with the Li-Ion battery. An overview of these products is given in paragraph 2.8.

5.4.1. Continuous Battery Monitoring

The Battery monitoring software is able to continuously monitor and relay the following battery properties:

Status

- Serial number: This is the software identification number of the battery
- Voltage: This is the terminal voltage of the battery
- Current: This is the actual current that runs through the battery
- Temperature: this is the highest temperature in the battery
- Charge: the State Of Charge
- Cycles: the number of cycles the battery has completed in its lifetime
- Capacity: The nominal battery capacity
- Status
 - Battery ready: everything is in order or there is a fault condition
 - Overvoltage: A voltage that is too high, resulting in overloading the battery
 - Undervoltage: Voltage that is too low, which indicates that the battery is flat
 - Overcurrent Charge: The battery is charged with a current that is too high
 - Overcurrent Discharge: The battery is discharged with a current that is too high
 - High Temperature: The battery is too hot
 - Fuse: The fuse is broken
- Ucell, the voltages of the cells in the battery
- TCell, the temperatures of the cells
- Tcase, The temperature of the case
- Tfuse, the temperature of the fuse
- Tshunt, the temperature of the shunt resistor
- Cleft, available instantaneous energy
- Rshunt, nominal resistance value of the calibrated resistance

Logging

Showing the battery log.

Statistics

Error counters

- Overvoltage, the number of times the charging voltage has been too high
- Undervoltage, the number of times the battery has been discharged too deeply
- Overtemp, the number of times the battery has been too hot
- Overcurrent Charge, the number of times the battery has received too much charging current

- Overcurrent Discharge, the number of times that too much current has been withdrawn from the battery
- Fuse, the number of times the fuse has been broken

Cell Voltages and Temperature

Four rows, one for each cell, four columns with the following contents

- Umin, lowest cell voltage ever
- Umax, highest cell voltage ever
- Tmin, lowest cell temperature ever
- Tmx, highest cell temperature ever

Temperatures

- Fuse, a column for the lowest and highest fuse temperature ever
- Case, a column for the lowest and the highest case temperature ever
- Shunt, a column for the lowest and highest shunt resistor temperature ever

5.4.2. Battery History Recording

The complete battery history can be downloaded with the battery monitor software. This recording can only be accessed by a reseller or Super B for evaluation.

6. Inspection, cleaning and maintenance

6.1. General information

⚠ Warning! Never attempt to open or dismantle the battery! The inside of the battery does not contain serviceable parts.

1. Disconnect the Li-Ion battery from all loads and charging devices before performing cleaning and maintenance activities (see paragraph 4.5.5).
2. Remove the fuse or dummy fuse before cleaning and maintenance activities (see paragraph 4.3.2).
3. Place the enclosed protective caps over the terminals before cleaning and maintenance activities to avoid the risk of contacting the terminals.

6.2. Inspection

1. Inspect for loose and/or damaged wiring and contacts, cracks, deformations, leakage or damage of any other kind. If damage to the battery is found, it must be replaced. Do not attempt to charge or use a damaged battery. Do not touch the liquid from a ruptured battery
2. Observe and note the run time that a new, fully-charged battery provides for powering your product. Use this new battery run time as a basis to compare run times for older batteries.

The run time of the Li-Ion battery will vary depending on the products' configuration and the application it is used for.

3. Routinely check the battery's charge status. Lithium Iron Phosphate batteries continue to slowly self-discharge (10% per year) when not in use or whilst in storage.
4. Carefully monitor batteries that are approaching the end of their estimated life.
5. Consider replacing the battery with a new one if you note either of the following conditions:
 - The battery run time drops below about 80% of the original run time.
 - The battery charge time increases significantly.

6.3. Cleaning

If necessary, clean the Li-Ion battery with a soft, dry cloth. Never use liquids, solvents, or abrasives to clean the Li-Ion battery.

6.4. Maintenance

The Li-Ion battery is maintenance free. Charge the battery to approximately 50% of its capacity at least once every year to preserve the battery's capacity.

7. Storage

Follow the storage instructions in this manual to optimize the lifespan of the battery during storage. If these instructions are not followed and the Li-Ion battery has no charge remaining when it is checked, consider it to be damaged. Do not attempt to recharge or use it. Replace it with a new battery.

1. Remove the fuse from the battery during storage. (See paragraph 4.3.2)
2. Disconnect the Li-Ion battery from all loads and, if present, the charging device.
3. Place the terminal covers over the battery's terminals during storage.
4. Store the battery in a cool and well ventilated space.
5. Avoid exposure of the battery to sunlight and/or UV radiation.
6. Charge or discharge the battery to 50% of its capacity before storage.
7. Charge the battery to approximately 50% of its capacity at least once every year.

8. Transportation

8.1. General

Always check all applicable local, national, and international regulations before transporting a Lithium Iron Phosphate battery.

Transporting an end-of-life, damaged, or recalled battery may, in certain cases, be specifically limited or prohibited.

The transport of the Li-Ion battery falls under hazard class UN3480, class 9. For transport over water, air and land, the battery falls within packaging group PI965 Section I.



Use Class 9 Miscellaneous Dangerous Goods and UN Identification labels for transportation of lithium ion batteries which are assigned Class 9. Refer to relevant transportation documents. Lithium batteries and lithium ion cells are regulated in the U.S. in accordance with Part 49 of the Code of Federal Regulations, (49 CFR Sections 105-180) of the U.S. Hazardous

Materials Regulations.

Visit www.iata.org for the complete transport regulations and packing instructions for this product. The relevant information for Lithium batteries can be found under "Programs" > "Cargo" > "Dangerous goods (HAZMAT)".

9. Disposal and recycling

9.1. General information

Always discharge the battery before disposal. Use electrical tape or other approved covering over the battery connection points to prevent short circuits.

Battery recycling is encouraged. Dispose of the battery in accordance with local, state and federal laws and regulations. Batteries may be returned to the manufacturer.

USA & Canada:

Lithium Iron Phosphate batteries are subject to disposal and recycling regulations that vary by country and region. Always check and follow your applicable regulations before disposing of any battery. Contact Rechargeable Battery Recycling Corporation (www.rbrcc.org) for U.S.A. and Canada, or your local battery recycling organization.

EC

Waste must be disposed of in accordance with relevant EC Directives and national, regional and local environmental control regulations. For disposal within the EC, the appropriate code according to the European Waste Catalogue (EWC) should be used.

Other

Many countries prohibit the disposal of waste electronic equipment in standard waste receptacles.

10. Troubleshooting

Problem	Possible reason	Solution
The capacity of battery has decreased	The cells within the battery are not properly balanced, causing them to discharge at different rates.	Connect the Monitor Software to the battery to verify the status of the battery. If the battery status “balancing required” is active, follow the procedures described in paragraphs 5.2.3 and 5.2.4 to balance the cells within the battery. If no difference is found, the lost capacity is due to battery aging. This process cannot be reversed.
The battery does not provide a charge / the battery cannot be charged	The fuse of the battery is not installed	Install the fuse; follow the procedures described in paragraph 4.3.2
	The fuse in the battery is broken	Disconnect all loads and chargers, check and correct for short circuits and defects. Then replace the fuse; follow the procedures described in paragraph 4.3.2
	The reset button was not pressed for 5 seconds after the installation of the fuse or after a fault condition.	Press the reset button for 5 seconds.
	Batteries connected in series may fail to charge if a defective battery is present in the series.	Check the series for defective batteries. If a defective battery is found, replace it.
	The battery has been discharged to deeply causing the battery management system to trigger the external switch off device. The BMS is now in “fault condition”.	Disconnect all loads and connect a charger to the battery. Then press the reset button for at least 5 seconds to resolve the “fault condition”. (The reset button can be found in the fuse compartment; see paragraph 2.7.)

Problem	Possible reason	Solution
	The battery has been overcharged, causing the battery management system to trigger the external switch off device. The BMS is now in "fault condition".	Disconnect the charger from the battery and press the reset button for at least 5 seconds to resolve the "fault condition". (The reset button can be found in the fuse compartment; see paragraph 2.7.)
	The batteries cells have become unbalanced. During charging one or more cells overcharge, causing the battery management system to trigger the external switch off device. The BMS is now in "fault condition".	Disconnect the charger from the battery and press the reset button for at least 5 seconds to resolve the "fault condition". (The reset button can be found in the fuse compartment; see paragraph 2.7.) Drain the battery, then equalize the battery's cells as described in paragraph 5.2.4.
	The battery has overheated causing the battery management system to trigger the external switch off device. The BMS is now in "fault condition".	Disconnect the charger and all loads and wait for the battery to cool down. Then press the reset button for at least 5 seconds to resolve the "fault condition". (The reset button can be found in the fuse compartment; see paragraph 2.7.)
A ticking sound can be heard from within the battery	The Battery Management System has detected an error and is trying to trigger an external switch off device to disconnect from the load/charger. The BMS uses an internal relay to do so. However no external switch off device is connected (to the BMS), causing the internal relay to keep firing.	Immediately disconnect the battery from the load and install a switch off device; see paragraph 4.5.1. Then press the reset button for at least 5 seconds to resolve the "fault condition".

11. Warranty and liability

11.1 Upon delivery, the customer is obliged to immediately verify whether the products have been damaged during transport. The customer must notify Super B of such transport damage as soon as possible, in any event no later than within three (3) days of delivery, by means of an accurate, written statement, stating the damage and where possible a photograph.

11.2 If the customer demonstrates that the products do not conform to the agreement, Super B has the option to repair and/or replace the relevant products by new products when returned and/or to refund the invoice value, exclusive of any dispatch costs.

11.3 If the customer is a private individual not acting for or on behalf of any company or business, the customer has the right to return the product to Super B within seven (7) days of delivery. In this event, goods returned are only accepted if the product and its original packaging are free of damage, while the dispatch costs for returning the goods shall be at the customer's expense.

11.4 Super B shall use its best endeavors to manufacture reliable and safe products and to deliver these to the customer.

11.5 Super B grants a three year limited warranty for manufacturing faults. 'Manufacturing faults' do not include damage caused as a result of (a) general tear and wear, (b) short circuit, (c) overcharging, (d) deep discharging, (e) a wrongful connection to engines and other devices, (f) the absence of an approved and properly installed external BMS relay or other switch off device (g) any other wrongful use contrary to the user instruction; and (h) any use contrary to the product specifications of that product.

11.6 Any liability to the customer in any case ends if the customer fails to notify Super B of the existence of the defect within three (3) days of having discovered the defect, in writing, in order to enable Super B to investigate this.

11.7 Any liability of Super B for damage suffered by the customer is in any case limited to the invoice amount of the relevant products. Super B can never be held liable for consequential damage or losses of profits, unless such damage has been caused by gross negligence or willful misconduct of Super B.

11.8 To the extent that a court determines that the limitation of liability as meant in clause 11.7 cannot be invoked against a particular claim for damages by the customer, Super B's liability for loss of property, damage to property and bodily injury (including death) caused by the application of those particular Super B products shall in any event be limited to the amount actually paid out by Super B's insurance company to Super B in accordance with the insurance cover of that insurance policy for that particular type of damage. Super B has taken out insurance against certain risks, namely for the application of Super B products in land vehicles and in aviation, respectively, each as described in the respective insurance policies. These policies contain a usual limitation of insurance payment to be paid out to Super B if, and to the extent that, the event is a covered event.

Appendix I. Declaration of Conformity

Super B b.v.

Diamantstraat 1e, 7554 TA, Hengelo, the Netherlands

+31 (0) 74-8200010, www.super-b.com

June 20, 2014

Declaration of Conformity

Product Number/Name/Description:

SB12V160E-ZC (Lithium Ion Battery) 13.2V / 160Ah / 2122Wh (Energy / TractionBattery)

The undersigned hereby declares, on behalf of Super B b.v. Hengelo, the Netherlands, that the above-referenced product, to which this declaration relates, is in conformity with the provisions of:

- Council Directive 2006/66/EC, Environmental EU Compliance
- Council Directive 2004/108/EC (December 15, 2004) on Electromagnetic Compatibility

European standards used:

- EN61000-6-3 (2007) +A1 (2011), EN 55016-2-3 (2010) + A1 (2010) + C1 (2013), EMC (Emission) Compliance
- EN61000-6-2 (2005) + AC (2005), EN 61000-4-2 (2009), EN 61000-3 (2006) + A1 (2008) + A2 (2010), EN 61000-4-4 (2012), EN 61000-4-5 (2007), EN 61000-4-6 (2009), EMI (Immunity) Compliance
- IEC 62133, Safety IEC Compliance
- IEC 61960{ed2.0}, Performance IEC Compliance

The Technical Construction File required by this Directive is maintained at the corporate headquarters of Super B b.v., Diamantstraat 1e, 7554TA, Hengelo, the Netherlands.

M.H. Doornekamp

CEO

Appendix II. Certificate of Compliance

Super B b.v.

Diamantstraat 1e, 7554 TA, Hengelo, the Netherlands
+31 (0) 74-8200010, www.super-b.com

June 20, 2014

Certificate of Compliance

Product Number/Name/Description:

SB12V160E-ZC (Lithium Ion Battery) 13.2V / 160Ah / 2122Wh (Energy / TractionBattery)

The undersigned, on behalf of Super B b.v. Hengelo, the Netherlands,, does hereby certify that the product listed above is compliant to:

- a) Transport Clasification UN3480
- b) UN 38.3; Part III; of the UN Recommendations on the TRANSPORT OF DANGEROUS GOODS.
- c) IEC 62281, Transportation IEC Compliance
- d) SP 230, Special provision
- e) SP 188 / PI965, Part II IATA , Packing instructions
- f) DIRECTIVE 2006/66/EC, Environmental EU Compliance
- g) IEC 62133, Safety IEC Compliance
- h) EN61000-6-3 (2007) +A1 (2011), EN 55016-2-3 (2010) + A1 (2010) + C1 (2013), EMC (Emission) Compliance
- i) EN 61000-6-2 (2005) + AC (2005), EN 61000-4-2 (2009), EN 61000-4-3 (2006) + A1 (2008) + A2 (2010), EN 61000-4-4 (2012), EN 61000-4-5 (2007), EN 61000-4-6 (2009), EMI (Immunity) Compliance
- j) IEC 61960{ed2.0}, Performance IEC Compliance

M.H. Doornekamp

CEO

Appendix III. Performance Graphs

Depth of Discharge v/s Cycle life

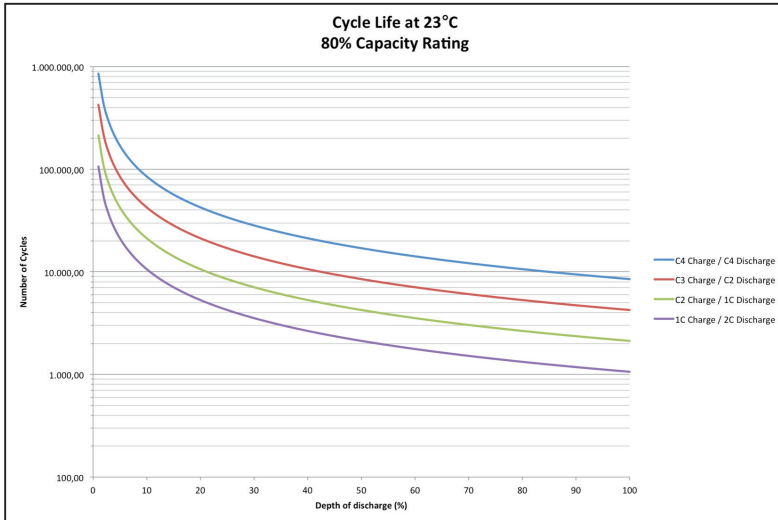

Temperature performance

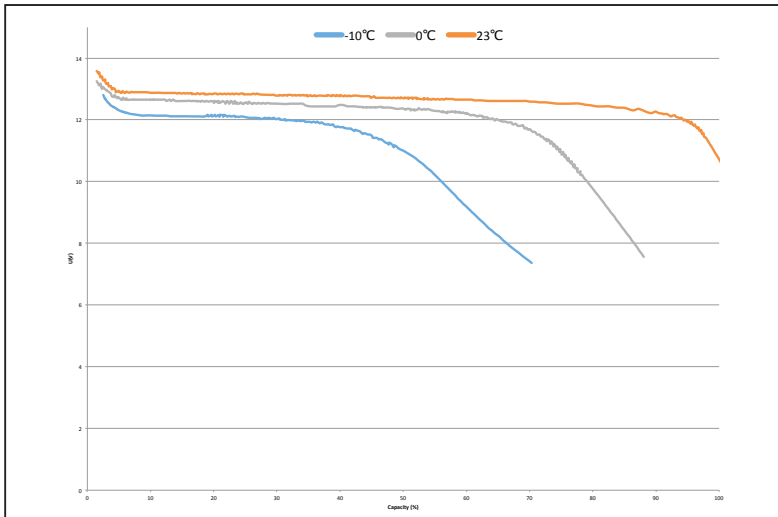

Load performance

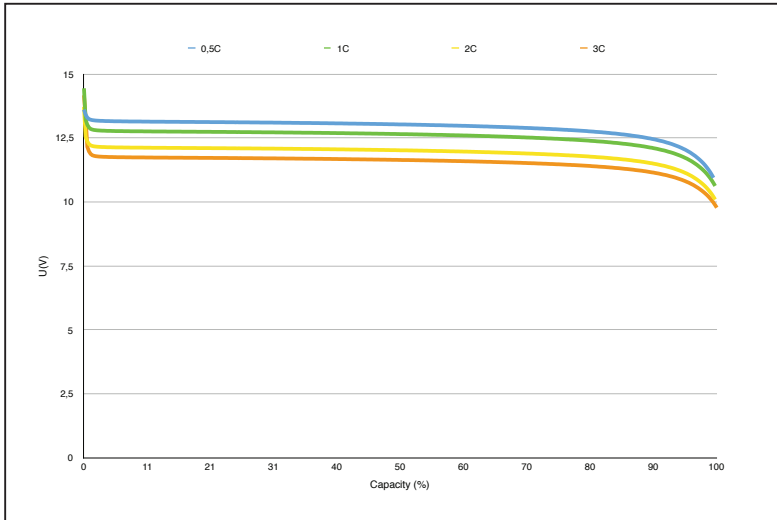

Peukert component

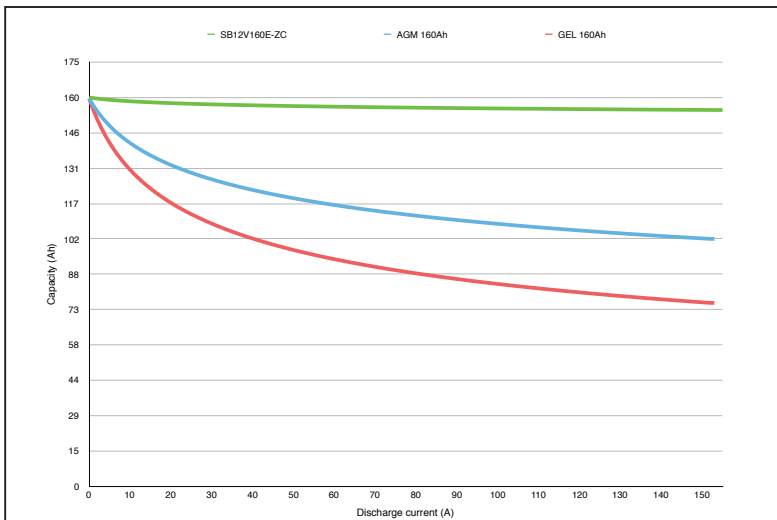

Appendix IV. Conductor requirements

Subject

Use appropriate wire for the connection wires to ensure no overheating or unnecessary losses occur. Consult the SAE-J378 or ISO 10133:2012 standards to determine the appropriate wire properties. Use appropriate fuses matching the wires and load.

The below information is a summary extracted from the ISO10133:2012, reading the ISO ISO10133:2012 is recommended.

Conductor requirements 12V d.c. system at 30 °C ambient temperature

Allowable maximum current, in amperes, for single conductors at insulation temperature ratings. With a maximum voltage drop of 3%.

- S is the conductor cross-sectional area, in square millimeters
- I is the load current, in amperes
- L is the length, in meters, of conductor from the positive power source to the electrical device and back to the negative source connection.

Conductors at insulation temperature 105 °C:

S / L	1	2	3	4	5	6	7	8	9	10	15	20	25	30	35	40	45	50	75	100
0,75	16	8	5	4	3	3	2	2	2	2	1	1	1	1	0	0	0	0	0	0
1	22	11	7	5	4	4	3	3	2	2	1	1	1	1	1	1	0	0	0	0
1,5	33	16	11	8	7	5	5	4	4	3	2	2	1	1	1	1	1	1	0	0
2,5	45	27	18	14	11	9	8	7	6	5	4	3	2	2	2	1	1	1	1	1
4	55	44	29	22	18	15	13	11	10	9	6	4	4	3	3	2	2	2	1	1
6	75	66	44	33	26	22	19	16	15	13	9	7	5	4	4	3	3	3	2	1
10	120	110	73	55	44	37	31	27	24	22	15	11	9	7	6	5	5	4	3	2
16	170	170	117	88	70	59	50	44	39	35	23	18	14	12	10	9	8	7	5	4
25	200	200	183	137	110	91	78	69	61	55	37	27	22	18	16	14	12	11	7	5
35	240	240	240	192	154	128	110	96	85	77	51	38	31	26	22	19	17	15	10	8
50	325	325	325	274	220	183	157	137	122	110	73	55	44	37	31	27	24	22	15	11
70	375	375	375	375	307	256	220	192	171	154	102	77	61	51	44	38	34	31	20	15
95	430	430	430	430	417	348	298	261	232	209	139	104	83	70	60	52	46	42	28	21
120	520	520	520	520	520	439	376	329	293	263	176	132	105	88	75	66	59	53	35	26
150	560	560	560	560	560	549	470	412	366	329	220	165	132	110	94	82	73	66	44	33

Conductors at insulation temperature 85 - 90 °C:

S / L	1	2	3	4	5	6	7	8	9	10	15	20	25	30	35	40	45	50	75	100
0,75	16	8	5	4	3	3	2	2	2	2	1	1	1	1	0	0	0	0	0	0
1	22	11	7	5	4	4	3	3	2	2	1	1	1	1	1	1	0	0	0	0
1,5	30	16	11	8	7	5	5	4	4	3	2	2	1	1	1	1	1	1	0	0
2,5	40	27	18	14	11	9	8	7	6	5	4	3	2	2	2	1	1	1	1	1
4	50	44	29	22	18	15	13	11	10	9	6	4	4	3	3	2	2	2	1	1
6	70	66	44	33	26	22	19	16	15	13	9	7	5	4	4	3	3	3	2	1
10	100	100	73	55	44	37	31	27	24	22	15	11	9	7	6	5	5	4	3	2
16	150	150	117	88	70	59	50	44	39	35	23	18	14	12	10	9	8	7	5	4
25	185	185	183	137	110	91	78	69	61	55	37	27	22	18	16	14	12	11	7	5
35	225	225	225	192	154	128	110	96	85	77	51	38	31	26	22	19	17	15	10	8
50	300	300	300	274	220	183	157	137	122	110	73	55	44	37	31	27	24	22	15	11
70	360	360	360	360	307	256	220	192	171	154	102	77	61	51	44	38	34	31	20	15
95	410	410	410	410	410	348	298	261	232	209	139	104	83	70	60	52	46	42	28	21
120	480	480	480	480	480	439	376	329	293	263	176	132	105	88	75	66	59	53	35	26
150	520	520	520	520	520	520	470	412	366	329	220	165	132	110	94	82	73	66	44	33

Conductors at insulation temperature 70 °C:

S / L	1	2	3	4	5	6	7	8	9	10	15	20	25	30	35	40	45	50	75	100
0,75	16	8	5	4	3	3	2	2	2	2	1	1	1	1	0	0	0	0	0	0
1	20	11	7	5	4	4	3	3	2	2	1	1	1	1	1	1	0	0	0	0
1,5	25	16	11	8	7	5	5	4	4	3	2	2	1	1	1	1	1	1	0	0
2,5	35	27	18	14	11	9	8	7	6	5	4	3	2	2	2	1	1	1	1	1
4	45	44	29	22	18	15	13	11	10	9	6	4	4	3	3	2	2	2	1	1
6	60	60	44	33	26	22	19	16	15	13	9	7	5	4	4	3	3	3	2	1
10	90	90	73	55	44	37	31	27	24	22	15	11	9	7	6	5	5	4	3	2
16	130	130	117	88	70	59	50	44	39	35	23	18	14	12	10	9	8	7	5	4
25	170	170	170	137	110	91	78	69	61	55	37	27	22	18	16	14	12	11	7	5
35	210	210	210	192	154	128	110	96	85	77	51	38	31	26	22	19	17	15	10	8
50	270	270	270	270	220	183	157	137	122	110	73	55	44	37	31	27	24	22	15	11
70	330	330	330	330	307	256	220	192	171	154	102	77	61	51	44	38	34	31	20	15
95	390	390	390	390	390	348	298	261	232	209	139	104	83	70	60	52	46	42	28	21
120	450	450	450	450	450	439	376	329	293	263	176	132	105	88	75	66	59	53	35	26
150	475	475	475	475	475	475	470	412	366	329	220	165	132	110	94	82	73	66	44	33

Conductor requirements 48V d.c. system at 30 °C ambient temperature

Allowable maximum current, in amperes, for single conductors at insulation temperature ratings. With a maximum voltage drop of 3%.

- S is the conductor cross-sectional area, in square millimeters
- I is the load current, in amperes
- L is the length, in meters, of conductor from the positive power source to the electrical device and back to the negative source connection.

Conductors at insulation temperature 105 °C:

S / L	1	2	3	4	5	6	7	8	9	10	15	20	25	30	35	40	45	50	75	100
0,75	12	8	5	4	3	3	2	2	2	2	1	1	1	1	0	0	0	0	0	0
1	18	11	7	5	4	4	3	3	2	2	1	1	1	1	1	1	0	0	0	0
1,5	21	16	11	8	7	5	5	4	4	3	2	2	1	1	1	1	1	1	0	0
2,5	30	27	18	14	11	9	8	7	6	5	4	3	2	2	2	1	1	1	1	1
4	40	40	29	22	18	15	13	11	10	9	6	4	4	3	3	2	2	2	1	1
6	50	50	44	33	26	22	19	16	15	13	9	7	5	4	4	3	3	3	2	1
10	70	70	70	55	44	37	31	27	24	22	15	11	9	7	6	5	5	4	3	2
16	100	100	100	88	70	59	50	44	39	35	23	18	14	12	10	9	8	7	5	4
25	140	140	140	137	110	91	78	69	61	55	37	27	22	18	16	14	12	11	7	5
35	185	185	185	185	154	128	110	96	85	77	51	38	31	26	22	19	17	15	10	8
50	230	230	230	230	220	183	157	137	122	110	73	55	44	37	31	27	24	22	15	11
70	285	285	285	285	285	256	220	192	171	154	102	77	61	51	44	38	34	31	20	15
95	330	330	330	330	330	330	298	261	232	209	139	104	83	70	60	52	46	42	28	21
120	400	400	400	400	400	400	376	329	293	263	176	132	105	88	75	66	59	53	35	26
150	430	430	430	430	430	430	430	412	366	329	220	165	132	110	94	82	73	66	44	33

Conductors at insulation temperature 85 - 90 °C:

S / L	1	2	3	4	5	6	7	8	9	10	15	20	25	30	35	40	45	50	75	100
0,75	10	8	5	4	3	3	2	2	2	2	1	1	1	1	0	0	0	0	0	0
1	14	11	7	5	4	4	3	3	2	2	1	1	1	1	1	1	0	0	0	0
1,5	18	16	11	8	7	5	5	4	4	3	2	2	1	1	1	1	1	1	0	0
2,5	25	25	18	14	11	9	8	7	6	5	4	3	2	2	2	1	1	1	1	1
4	35	35	29	22	18	15	13	11	10	9	6	4	4	3	3	2	2	2	1	1
6	45	45	44	33	26	22	19	16	15	13	9	7	5	4	4	3	3	3	2	1
10	65	65	65	55	44	37	31	27	24	22	15	11	9	7	6	5	5	4	3	2
16	90	90	90	88	70	59	50	44	39	35	23	18	14	12	10	9	8	7	5	4

25	120	120	120	120	110	91	78	69	61	55	37	27	22	18	16	14	12	11	7	5
35	160	160	160	160	154	128	110	96	85	77	51	38	31	26	22	19	17	15	10	8
50	210	210	210	210	210	183	157	137	122	110	73	55	44	37	31	27	24	22	15	11
70	265	265	265	265	265	256	220	192	171	154	102	77	61	51	44	38	34	31	20	15
95	310	310	310	310	310	310	298	261	232	209	139	104	83	70	60	52	46	42	28	21
120	360	360	360	360	360	360	360	329	293	263	176	132	105	88	75	66	59	53	35	26
150	380	380	380	380	380	380	380	380	366	329	220	165	132	110	94	82	73	66	44	33

Conductors at insulation temperature 70 °C:

S / L	1	2	3	4	5	6	7	8	9	10	15	20	25	30	35	40	45	50	75	100
0,75	6	6	5	4	3	3	2	2	2	2	1	1	1	1	0	0	0	0	0	0
1	8	8	7	5	4	4	3	3	2	2	1	1	1	1	1	1	0	0	0	0
1,5	12	12	11	8	7	5	5	4	4	3	2	2	1	1	1	1	1	1	0	0
2,5	17	17	17	14	11	9	8	7	6	5	4	3	2	2	2	1	1	1	1	1
4	22	22	22	22	18	15	13	11	10	9	6	4	4	3	3	2	2	2	1	1
6	29	29	29	29	26	22	19	16	15	13	9	7	5	4	4	3	3	2	1	1
10	40	40	40	40	40	37	31	27	24	22	15	11	9	7	6	5	5	4	3	2
16	54	54	54	54	54	54	50	44	39	35	23	18	14	12	10	9	8	7	5	4
25	71	71	71	71	71	71	71	69	61	55	37	27	22	18	16	14	12	11	7	5
35	87	87	87	87	87	87	87	87	85	77	51	38	31	26	22	19	17	15	10	8
50	105	105	105	105	105	105	105	105	105	110	73	55	44	37	31	27	24	22	15	11
70	135	135	135	135	135	135	135	135	135	135	102	77	61	51	44	38	34	31	20	15
95	165	165	165	165	165	165	165	165	165	165	139	104	83	70	60	52	46	42	28	21
120	190	190	190	190	190	190	190	190	190	190	176	132	105	88	75	66	59	53	35	26
150	220	220	220	220	220	220	220	220	220	220	220	165	132	110	94	82	73	66	44	33

Derating of conductors in ambient temperatures of 60 °C

For conductors in 60 °C ambient, the maximum current rating in the above tables shall be derated by the factors below.

Temperature rating of conductor insulation, °C	Multiply maximum current from Table by:
70	0,75
85 – 90	0,82
105	0,86
125	0,89
200	1



super B Lithium batteries to perform better



For more information, or to order documents,
contact:

Super B b.v.
Diamantstraat 1e
7554 TA Hengelo (Ov)
The Netherlands

Tel: +31(0)748200010
Fax: +31(0)748200011
E-mail: info@super-b.com
www: www.super-b.com

