

customer service

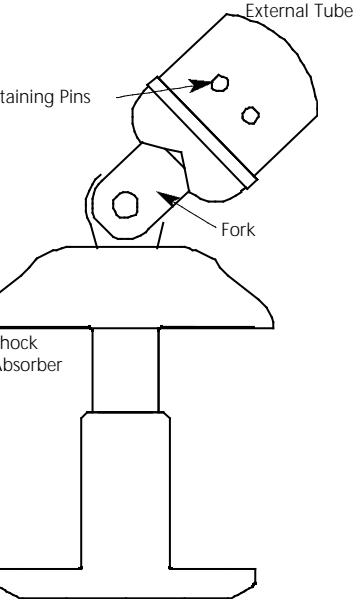

### E-JOINT / Tube Assembly

Spinlock's after sales service is available worldwide through our distribution network. Should you need any help in obtaining spare parts, or advice with repairs, your local Spinlock expert can provide a fast and professional service.

E-SERIES	E-HDL	EA-HDL	Handle option parallel
E-SERIES	E-GRIP	E-HDL	Tube sleeve grip
E-SERIES	E-DIABOLO	E-HDL	Stand up universal joint
E-SERIES	E-JOINT	E-HDL	Full swivel joint with fastpin
E-SERIES	E-SHOCK	E-HDL	Shock absorber
E-SERIES	E-SLEEVE	E-HDL	Replacement pivot housing
E-SERIES	E-FASTPIN	E-HDL	Full swivel joint release pin
E-SERIES	E-BUTTON	E-HDL	Control button
E-SERIES	E-CLIP	E-HDL	Tiller clip
Pre 1998 C/SERIES	CS06	E-HDL	Full swivel joint with fastpin
Pre 1998 C/SERIES	CS411	E-HDL	Button
Pre 1998 C/SERIES	CS432	E-HDL	Tiller clip; use E-CLIP
Pre 1998 C/SERIES	CS02B	E-HDL	Use E-SLEEVE

customer service

### Maintenance

- Spinlock products are made from the best quality materials for durability and low maintenance in a harsh marine environment.
- For reliable operation, flush your tiller extension regularly with FRESH water to remove salt.
- Do not lubricate locking mechanism. Mineral oil & solvent based lubricants like "WD40" will accelerate the ageing of plastic components and attracts debris into ball lock mechanism.
- Never sail with a damaged or bent tiller extension.

customer support

USA	USA	Marine Trading Company LLC	T: +1 860 767 0468
USA	ARGENTINA	Tinner S.A.	T: +54 11 4580 0444
USA	BRAZIL	Regata Sport Ltd	T: +55 11 3030 3400
USA	AUSTRALIA	Spinlock Australia Pty Ltd	T: +61 2 9905 9400
USA	BRITISH VIRGIN ISLANDS	Richardsons Rigging	T: +34 93 221 9219
USA	SWEDEN	Sportsmanship AB	T: +46 31 939 400
USA	SWITZERLAND	Bücher & Wält SA	T: +41 32 755 9500
USA	NEW CALEDONIA	Marnac Coral Noumea	T: +687 27 58 48
USA	NEW ZEALAND	Power & Marine Ltd	T: +64 9 145 555
USA	SOUTH AFRICA	Central Boating (Pty) Ltd	T: +27 21 424 8026
USA	CANADA	Transat Marine Ltd	T: +39 02 569 5906
USA	MALTA	Deck Marine SPA	T: +350 22 569 5906
USA	ITALY	Coltli	T: +361 466 8320
USA	UNITED KINGDOM	Marathon Leisure Ltd	T: +44 23 9263 7711
USA	HUNGARY	Túrzan A.S.	T: +90 212 696 99 15
USA	GREECE	Perga SA	T: +30 1412 5069
USA	GIBRALTAR	H. Sheppard & Co Ltd	T: +350 75148
USA	GERMANY	Peter Frach GmbH	T: +49 8936 5075
USA	FRANCE	Interster	T: +33 2 99 19 54 54
USA	SLOVENIA	SeaWay d.o.o.	T: +386 45 302 444
USA	FINLAND	Oy Vestek AB	T: +358 9 887 0120
USA	DENMARK	Columnbus Marine A/S	T: +45 46 1911 66
USA	BENELUX	Mare Marine bv	T: +31 172 506 820
USA	NORWAY	Marine Trading Company LLC	T: +47 33 041 591

customer service

### How to install new swivel joint

- Remove any packaging on tube or E-JOINT.
- Insert plastic swivel end into tube.
- Ensure no damage to tube and that plastic moulding is inserted into tube such that stainless retaining pins will locate thro' tube into moulding.
- Insert stainless fork.
- Insert both stainless retaining pins, ensuring fork, tube and moulding are captive.
- Note: Do not force or strike the E-JOINT onto the tube.

E-SERIES	EA-HDL	Poignée A-symétric
E-SERIES	E-HDL	Poignée droite
E-SERIES	E-GRIP	Crip en mousse
E-SERIES	E-DIABOLO	Articulation diabolo
E-SERIES	E-JOINT	Articulation inox complète avec fastpin
E-SERIES	E-SHOCK	Amortisseur de chocs
E-SERIES	E-SLEEVE	Erbase
E-SERIES	E-FASTPIN	Axe détachable fastpin
E-SERIES	E-BUTTON	Bouton de commande
E-SERIES	E-CLIP	Clip de barre
E-SERIES	CS02B	Utilisez E-SLEEVE (remplace votre ancienne erbase)
E-SERIES	CS432	Clip de barre; utilisez E-CLIP
E-SERIES	CS411	Bouton de commande
E-SERIES	CS06	Articulation inox complète avec fastpin
E-SERIES	CS06	pour les stics pré-98 (C/Series)

Le service Après-vente Spinlock est garanti à travers le monde grâce à notre réseau de distribution.

Si le besoin d'un conseil ou de pièces détachées se présentez, votre distributeur local Spinlock saura vous donner un service rapide et de qualité.

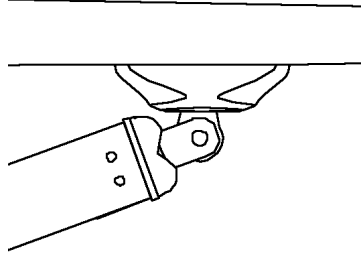

### Replacement Swivel Joint E series

the experts in ropoholding



### How to remove old swivel joint

Remove the two retaining stainless pins from existing swivel end, using hammer and tap.

Once both pins have been removed, the swivel end can be removed from tube. Simply pull tube and swivel end apart.