

← SEE NEXT PAGE

Ask your local Distributor for the warranty period in your region by calling their Service Center. Any part of the product supplied by the Distributor and found in the product including any defective part must be sent to the Distributor within the warranty period. The customer will pay for the expense of delivering the product to the Distributor. The Distributor will pay for the expense of returning the product to the customer.

Distributors in the United States and Canada provide a standard Limited Warranty for 6 months from the date of purchase for new products. If you're not located in the United States or Canada, please contact your local distributor for warranty arrangements in your territory. Please visit www.seadooseascooter.com for distributor/Service Centre details. Distributors ONLY warrant the products purchased from an authorized dealer.

ALWAYS ACTIVATE YOUR WARRANTY IMMEDIATELY ON
<http://www.seadooseascooter.com/warranty.html>

Distributors ONLY warrant products with an active
Warranty Registration

WARRANTY

www.seadooseascooter.com



SEA-DOO

User Manual

English Version

SDP05802



SEA-DOO® SEASCOOTER™ DOLPHIN
Model no. SD5542

SEA-DOO® SEASCOOTER™ AQUA RANGER
Model no. SD95001

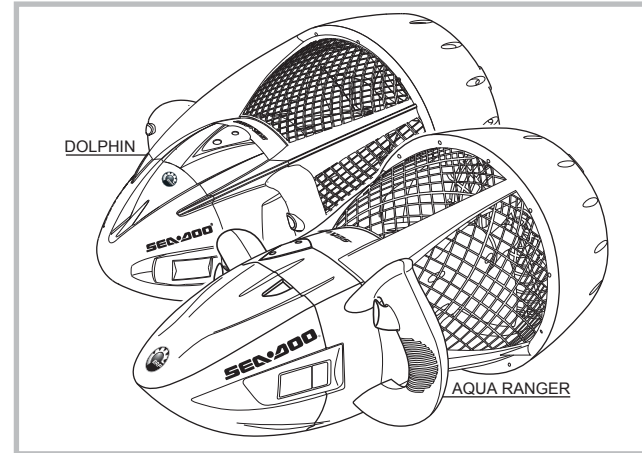

CAUTION

ELECTRICALLY OPERATED PRODUCT

Not recommended for children under 8 years of age. As with all electrical products, precautions should be observed during handling and used to reduce the risk of electric shock.

Contents

Introduction	1
Parts diagram	2
Warnings	4
Fit the rubber seal before first use!	6
Getting started	10
Battery use	11
Charging the battery	15
Care & maintenance	18
Trouble shooting	20
Technical specifications	24



Discarded electric appliances are recyclable and should not be discarded in the domestic waste! Please actively support us in conserving resources and protecting the environment by returning this appliance to the collection centres (if available).



Introduction

Thank you for having chosen the SEA-DOO® SEASCOOTER™ Dolphin / Aqua Ranger.

The Dolphin / Aqua Ranger adds a new dimension of fun and excitement to swimming and snorkeling.

Use appropriate equipment such as wetsuit, approved life jacket, mask & snorkel etc. when using seascooter.

Only operate the Seascooter in water.

-Dolphin-

- Speed up to Up to 2 mph (3.2 km/h)
- Run up to 90 minutes with normal use
- Rated to 15 ft / 5 m
- Weight just 12 lbs (5.4 kg) including battery

-Aqua Ranger-

- Speed up to Up to 2.5 mph (4.0 km/h)
- Run up to 60 minutes with normal use
- Rated to 30 ft / 10 m
- Weight just 11.5 lbs (5.2 kg) including battery

The Dolphin / Aqua Ranger feature various safety features making it safe for kids ages 8 and up. These are positive buoyancy, protective grilles, auto shut off when triggers are released and safety lock.

Please study this manual to get the most out of your Dolphin / Aqua Ranger.

Warning!

- The seascooter is designed for 1 person use.
- The seascooter is not a life saving device. Do not use it as a buoyancy aid.

Parts Diagram

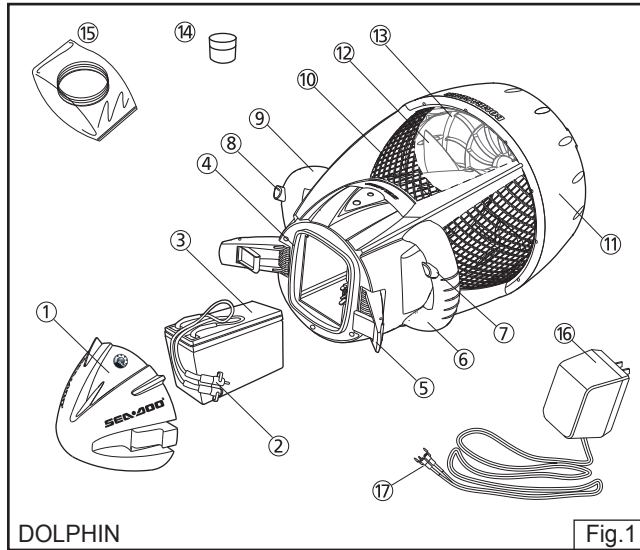

- | | | | |
|---|-----------------------------|---|-----------------|
| ① | Nose Cone | ⑩ | Front Grille |
| ② | Battery leads and Connector | ⑪ | Nozzle |
| ③ | Battery | ⑫ | Propeller |
| ④ | Seal | ⑬ | Rear Grille |
| ⑤ | Latch | ⑭ | Silicone Grease |
| ⑥ | Handle | ⑮ | O-ring Seals |
| ⑦ | ⑧ Trigger | ⑯ | Charger |
| ⑨ | Safety Switch | ⑰ | Charger Jack |

2

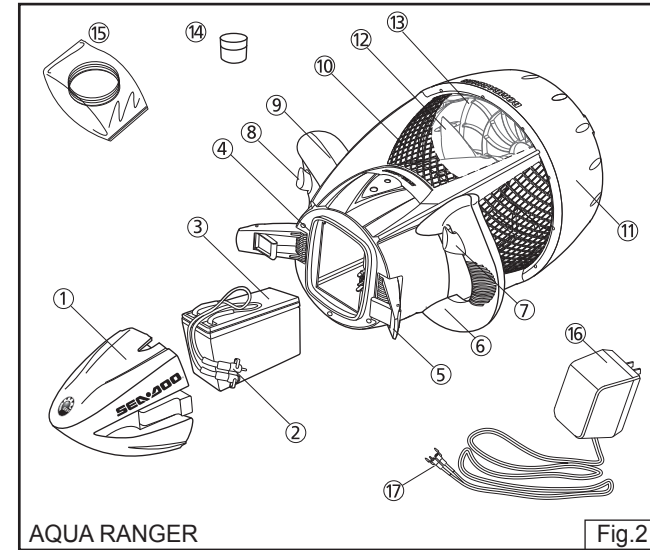

- | | | | |
|---|-----------------------------|---|-----------------|
| ① | Nose Cone | ⑩ | Front Grille |
| ② | Battery leads and Connector | ⑪ | Nozzle |
| ③ | Battery | ⑫ | Propeller |
| ④ | Seal | ⑬ | Rear Grille |
| ⑤ | Latch | ⑭ | Silicone Grease |
| ⑥ | Handle | ⑮ | O-ring Seals |
| ⑦ | ⑧ Trigger | ⑯ | Charger |
| ⑨ | Safety Switch | ⑰ | Charger Jack |

3



Warning

Not to be used by children under the age of eight (8) and must ONLY be used by children under adult supervision.

An adult must be responsible for battery safety at all times, during use, storage and charging.

Use in a pool or in calm water and close to shore – DO NOT use in the open sea.

Only to be used in water in which the child is within its depth and under supervision.

- The Seascooter™ is not a personal floatation device - always wear a Approved Personal Floatation Device / Approved Life-Preserver when using the Seascooter™.
- Read the user manual carefully.
- Never stick body parts, clothing or other objects in the vicinity of the propeller.
- Do not wear loose or flowing clothing or equipment that could be drawn into the propeller.
- Particular care should be exercised when using the Seascooter™ near anybody with long hair. Users with long hair should tie it up or wear a swimming cap when using the Seascooter™.
- Always inspect the swimming area to ensure it is free of hazards or obstacles such as boats and swimmers before using the Seascooter™.

4

- Always charge battery to its fullest before using the SEASCOOTER™. After charging is complete the battery will continue to emit gas. Wait at least 30 minutes after charging before removing the battery from the charger or placing the battery into the battery housing. Failure to do so could result in an explosion.
- ALWAYS ensure sufficient charges remains in the battery to return to the poolside, shore or surface before using the DOLPHIN / AQUARANGER.
- Do not use the Seascooter™ under the influence of alcohol or drugs.
- ALWAYS remove the battery from the unit when not in use.
- DO NOT store the battery in the unit.

Transportation for the seascooter :

Be careful when you are transporting or setting down the seascooter to avoid crushing hazard on foot or toes.

5

**FIT RUBBER SEAL
BEFORE FIRST USE!**

⚠ CRUSHING HAZARD:

Following action during assembly, disassembly or transportation of the seascooter might incur crushing hazard to your fingers or toes:

- Closing the nose cone latches
- putting on the nose cone housing
- setting down the seascooter or battery
- Accidental drop of the seascooter™ or battery.

DOLPHIN

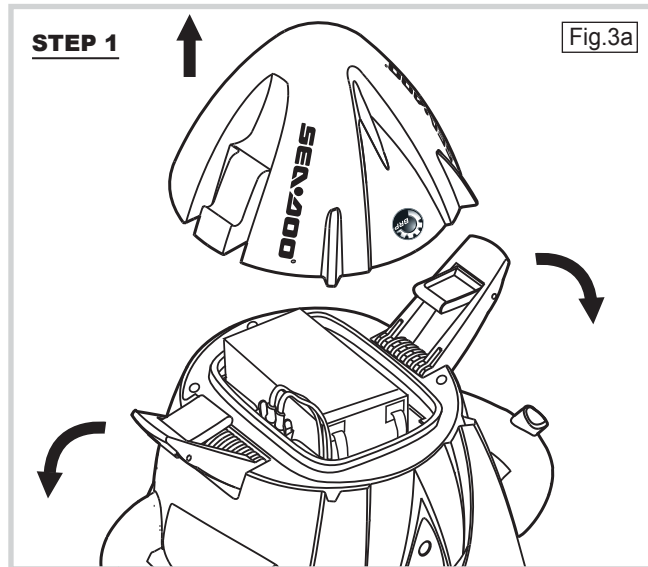

1. Unlock two latches and remove Nose Cone.

6

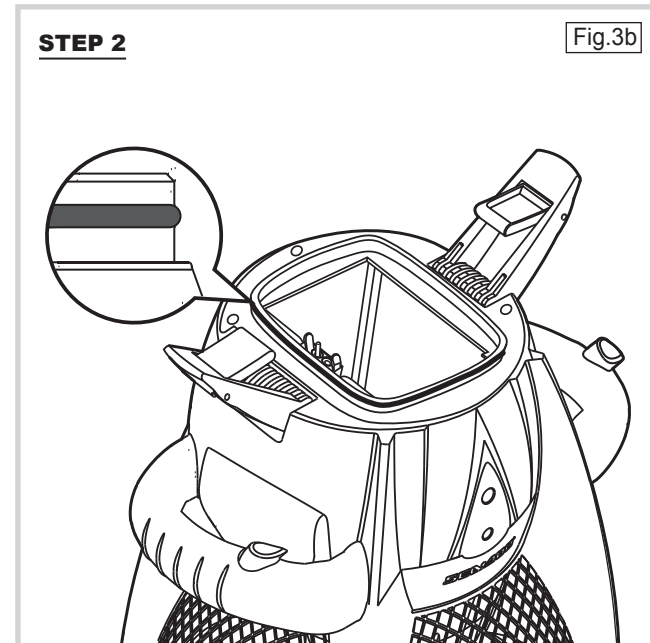

2. Rubber seal must be fitted as shown and lightly lubricated with the supplied grease.

7

AQUA RANGER

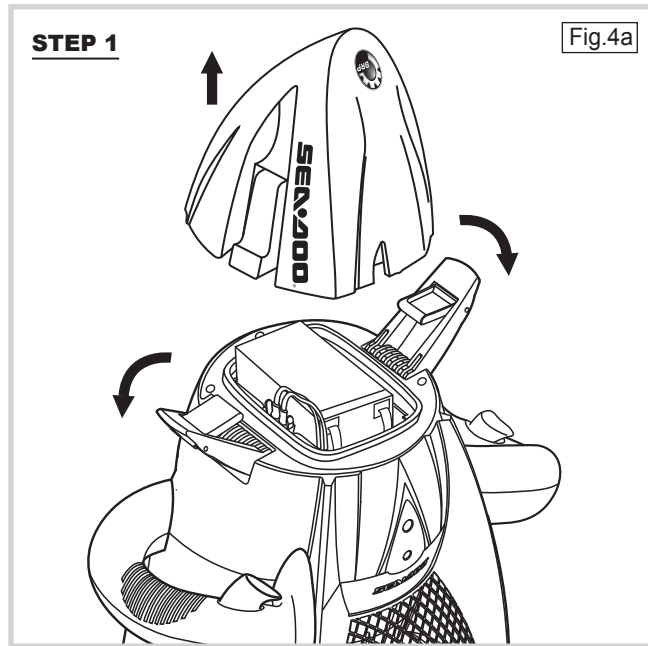

1. Unlock two latches and remove Nose Cone.

8

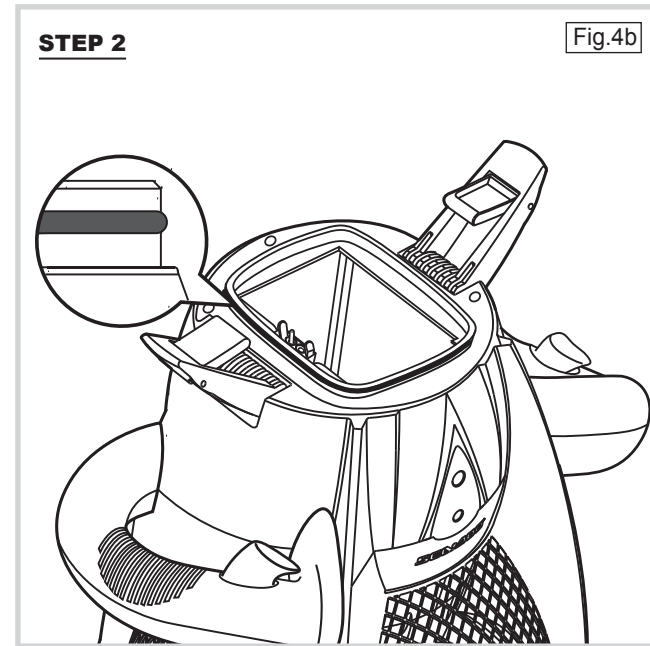

2. Rubber seal must be fitted as shown and lightly lubricated with the supplied grease.

9

Getting Started

When you buy the SEA-DOO® SEASCOOTER™ DOLPHIN / AQUA RANGER the battery is disconnected and needs to be charged. Follow the safety cautions on pages 11, 12, 13 and 14 and charging instructions on pages 15, 16 and 17.

Using the SEASCOOTER™ for swimming and snorkeling.

To use the SEASCOOTER™ for swimming or snorkeling follow these instructions.

1. Charge the battery and install just before use.
2. Place the SEA-DOO® SEASCOOTER™ DOLPHIN / AQUA RANGER into the water.
3. When ready to set off, switch the Safety Lock to the On position shown in fig. 5a.
4. Pull and hold both Triggers to start the Propeller. (There is a short delay before the Propeller begins to rotate).
5. To stop the Propeller, simply release one or both triggers.
6. Always set the Safety Lock to the Off position when out of the water - see fig. 5b.
7. ALWAYS remove the battery when not in use.

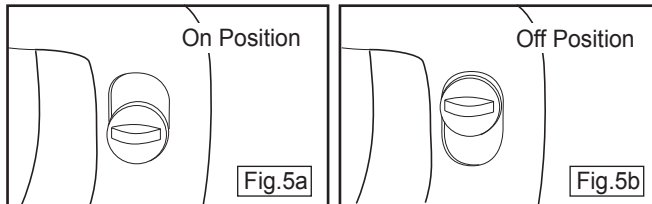

Important Notice: This machine is not to use to mix or to work with sand, concrete and material with similar physical characteristics. This machine is only to use for swimming and diving in water.

Battery Use

WARNING
BATTERY SAFETY

RE-CHARGE THE BATTERY
AT LEAST **3** EVERY
MONTHS

- Must remove and store the battery separately from the unit when not in use!
- Must re-charge the battery after use **WITHIN 24 HOURS**.
- Must re-charge the battery at least **EVERY THREE MONTHS** when not in use.

User Manual must be read and understood before use.
Please read and follow the **Battery Safety Instruction**.
Incorrect battery maintenance may reduce the battery life and influence its function.

www.seadooseascooter.com

Battery Use

- Your SEA-DOO® SEASCOOTER™ Dolphin / Aqua Ranger is supplied with a battery that needs to be treated carefully as it will release potentially explosive gases during its normal cycle of use (off-gassing). Failure to do so can result in an explosion occurring. Please read the entire manual thoroughly and follow all instructions.
- Always remove the battery from your SEA-DOO® SEASCOOTER™ Dolphin / Aqua Ranger when it is not in use and store separately in a well ventilated area where it is out of the reach of children and away from heat and ignition sources.
- Do not install the battery in your SEA-DOO® SEASCOOTER™ Dolphin / Aqua Ranger until immediately prior to using it.
- Before disconnecting/connecting any cables, open the nose cone and allow two minutes for any explosive gases to dissipate.
- Do not use/store/charge the battery in temperatures above 40°C (104°F) as excessive off-gassing may occur. Keep the battery and SEA-DOO® SEASCOOTER™ Dolphin / Aqua Ranger in the shade when not in use.
- Always ensure the unit is dried thoroughly before opening the Nose Cone.
- Only use the charger supplied with the SEA-DOO® SEASCOOTER™ Dolphin / Aqua Ranger.
- Charge the battery as soon as possible after use within 24 hours.

12

Battery Use

- Always charge the battery to the fullest before using the SEA-DOO® SEASCOOTER™ Dolphin / Aqua Ranger.
- The battery supplied with your SEA-DOO® SEASCOOTER™ Dolphin / Aqua Ranger releases a potentially explosive gas during charging. Charging should only take place in a well ventilated area, away from children and naked flames or other ignition sources (cigarettes, sparks). Never charge the battery whilst still in the SEA-DOO® SEASCOOTER™ Dolphin / Aqua Ranger.
- Always remove the battery from the battery housing before charging.
- Always connect charger jack to the battery first and then plug charger into the mains.
- After charging, disconnect from the mains first and then disconnect the battery from the charger.
- After charging is complete the battery will continue to emit gas. Wait at least 30 minutes after charging before removing the battery from the charger or placing the battery into the battery housing. Failure to do so could result in an explosion.
- Remove battery from charger once fully charged.
- Never charge the battery in sealed container.
- Never charge the battery near water.
- Never short circuit the battery or battery connectors.
- Always ensure the charger is dry before use.

13

Battery Use

CAUTION

- The charger gets quite warm in use - this is normal.
- If in doubt of the state of the battery, recharge it until the indicator on the battery charger indicates a full charge.
- If the battery is not to be used for an extended period, store it in a well ventilated area away from children, heat and ignition sources and recharge it every three months to maintain charge and avoid excess off gassing. DO NOT store the battery inside the SEA-DOO® SEASCOOTER™ Dolphin / Aqua Ranger.
- If the battery appears damaged or will not charge fully, the battery must be replaced. If battery life is noticeably reduced, the battery should be replaced.
- Do not recharge non-rechargeable battery. This charger only charges the Sealed rechargeable lead-acid 12V 7.5Ah battery, one battery per each charge.
- This appliance is not intended for use by persons (including children) with reduced physical, sensory or mental capabilities, or lack of experience and knowledge, unless they have been given supervision or instruction concerning use of the appliance by a person responsible for their safety. Children should be supervised to ensure that they do not play with the appliance.
- During charging, batteries must be placed in a well ventilated area.

14

Charging the battery

⚠ Warning!

Replace the battery immediately if it is damaged.

For battery charging follow these instructions.

1. Always ensure that the Safety Lock in the Off position is Off - see fig. 5b.
2. Always ensure that the SEA-DOO® SEASCOOTER™ Dolphin / Aqua Ranger is out of the water, dry and placed in a dry area.

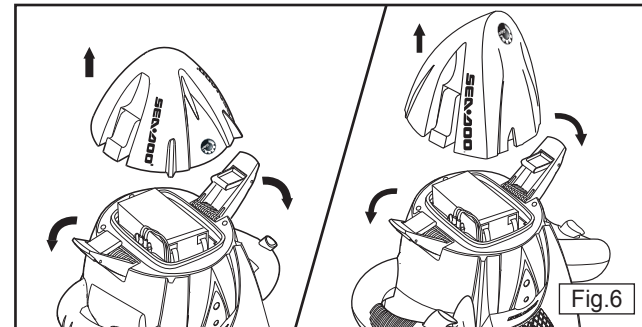

3. Pull the latches down and remove the Nose Cone as shown in fig. 6.
4. Allow two minutes for any gasses to dissipate.
5. Disconnect the battery cable from the housing cable (if not already disconnected - the cable will be disconnected when you buy your SEASCOOTER™) by pressing the locking feature, as shown in fig. 7.
6. Remove battery and place on a level surface.
7. Connect the battery cable to the charger cable.
8. Plug charger into mains, and turn on the supply.

15

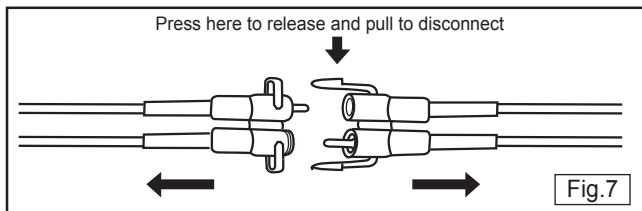

9. Charging will take 14-16 hours for a fully discharged battery. When the battery is charging the red LED is lit, when the battery is charged the green LED is lit.

10. Disconnect the Charger from the mains.

11. Unplug the battery cable from the charger cable.

12. Allow battery to stand for 30 minutes before using it.

13. When ready for use, place the battery into the housing and connect the housing cable.

14. Make sure the seal and sealing surfaces are clean and lubricated before replacing the Nose Cone. See fig. 8.

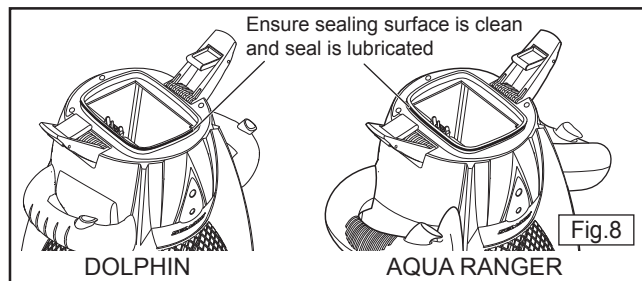

15. Replace the Nose Cone and close the latches.

To replace a flat battery with a fully charged battery.

1. Follow the steps 1 to 3 on page 15, to open the SEASCOOTER™.
2. Allow two minutes for gases to dissipate.
3. Unplug the battery at the socket by pressing the locking feature shown in fig. 7.
4. Remove the flat battery.
5. When ready for use, install and connect battery in the correct position, see fig. 9.

DO NOT STORE BATTERY IN SEASCOOTER.

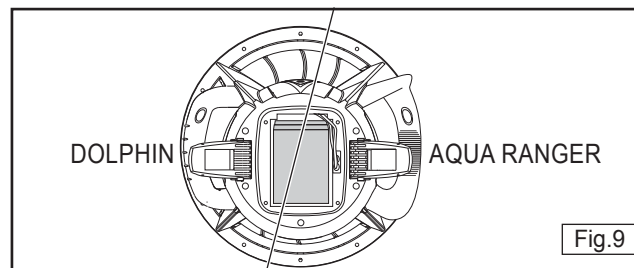

6. Follow steps 14 to 15 on page 16, to close the SEASCOOTER™.

Buying batteries

Additional batteries can be purchased separately. Contact your local customer service centre/distributor to purchase them.

Care And Maintenance

Battery and Catalyzer Care

Please read and understand important Battery Use safety information on page 11, 12, 13 and 14.

- The battery supplied with your SEA-DOO® SEASCOOTER™ should last about 200 cycles or two years before it should be replaced. Please contact your local customer service centre/distributor. Using a battery in excess of these recommendations can result in excessive off-gassing of explosive gases.
- A safety catalyzer, to protect against explosive gas in normal use, is held in a spring in the bottom of the battery housing and should be replaced at the same time as any battery replacement (Fig. 10). The catalyzer should be replaced sooner if it appears to be damaged. Please contact your local customer service centre/distributor.
- If the catalyzer is wet, it will not function and must be allowed to dry out before use.

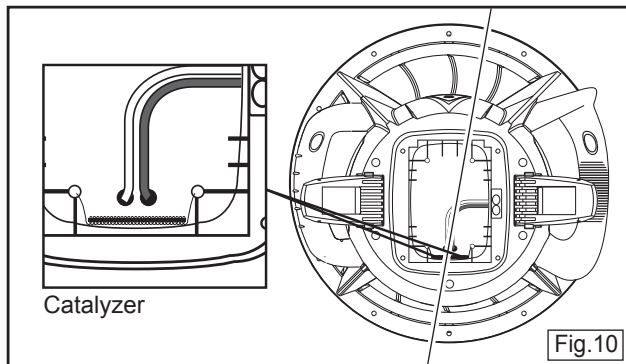

18

Care after using the SEASCOOTER™

ALWAYS remove the battery from the SEA-DOO® SEASCOOTER™ immediately after use.

DO NOT STORE BATTERY IN SEASCOOTER.

- Always rinse the SEASCOOTER™ in fresh water and allow it to dry before storage immediately after use.
- Whenever possible rinse the SEASCOOTER™ in fresh water immediately after use.
- To clean the SEASCOOTER™ do not use detergents, only use a damp cloth to wipe the unit clean.
- The Battery Housing interior should be kept dry at all times.
- If the Battery Housing interior ever gets wet, see page 23, Accidental Flooding for steps to take.
- When storing the SEASCOOTER™ for extended periods of time, open and remove the Nose Cone.
- ALWAYS store your SEASCOOTER™ vertically when not in use to prevent deformation of the Propeller Nozzle.

19

Trouble Shooting

Unit does not function

If the motor does not start when both triggers are pressed, make sure:

1. The battery is properly connected
2. The battery is fully charged
(see page 15, charging the battery)
3. The Safety Lock is in the "On" position
(see fig 5a, page 10)
4. There is no water in the battery compartment
(see page 23, accidental flooding)

Blocked Propeller

If the Propeller becomes blocked the Rear Grille and Propeller can be removed, to remove the obstacle.

Removing rear grille and Propeller to remove obstruction

Warning!

Crushing / Cutting Hazard

Before opening the grille for maintenance purpose, make sure the master switch is in off position, and the battery is disconnected.

1. Remove the SEASCOOTER™ from the water.
2. Make sure the Safety Lock is in the "Off" position.
3. Disconnect and remove the battery - see page 15, step1-6.
4. Unscrew the eight Rear Grille screws as shown in fig. 11.

20

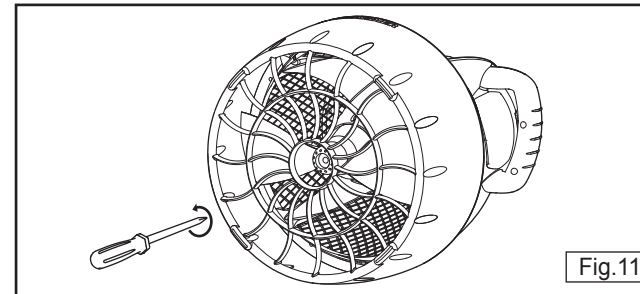

Fig.11

5. Whilst holding the Propeller, use an M6 socket to remove the nut from the Propeller shaft (See fig. 12).

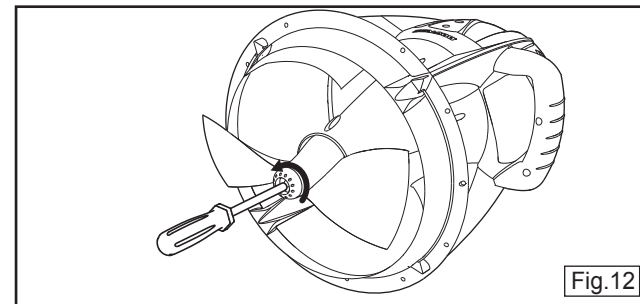
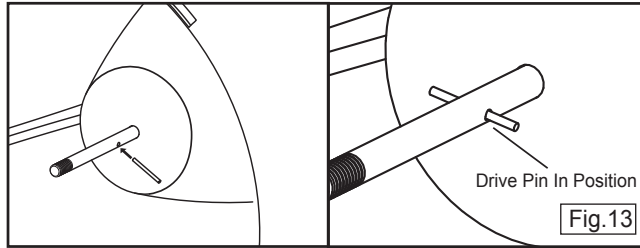

Fig.12

6. Slide the Propeller off the shaft, taking care not to lose the drive pin or washers.
7. Remove the blockage from the Propeller.
8. Replace the drive pin (if removed), see fig. 13, and Propeller. Turn the Propeller slowly until you locate the pin and push the Propeller fully on.

21



9. Replace the washer and nut and tighten with the socket whilst holding the Propeller making sure it is securely fastened (See fig. 14).

10. Replace the Rear Grille

11. Replace the battery and connect and replace the Nose Cone.

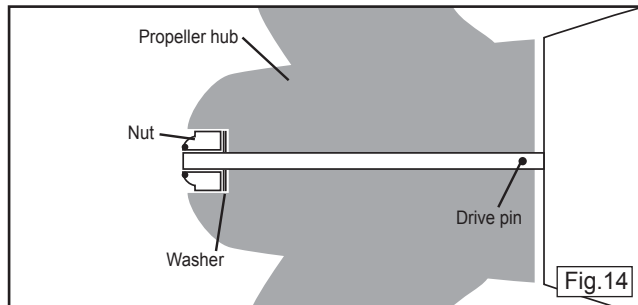

Sand or Grit on Seal

Sand or grit is the enemy of seals. Correct maintenance and care is essential. To remove sand or grit from the seal, rinse the seal in fresh water and apply fresh lubricant. If there is sand inside the Battery Housing, gently brush the sand from the unit taking care not to scratch the sealing surfaces.

Accidental Flooding

Be sure to keep the seal sand and grit free to ensure it keeps water out and to close the latches fully after accessing the battery chamber. However, should the seal not be clean or the latches not fully closed and water enter the battery chamber, your SEASCOOTER will not be damaged as it is designed for protection against accidental flooding.

If water enters the battery chamber.

1. Remove the unit from the water, open the nose cone and tip any excess water out.
2. Wait two minutes for any gases to dissipate, then remove the battery.
3. If salt water has entered, rinse battery housing and battery with fresh water.
4. Dry housing and battery thoroughly.
5. A safety catalyzer, to protect against explosive gas in normal use, is held in a spring in the bottom of the battery housing. If the catalyzer is wet, it will not function and must be allowed to dry out before use.

Technical Specifications

-DOLPHIN-

Unit Dimensions	11.25 inches x 11.25 inches x 19 inches (285 mm x 283 mm x 483 mm)
Unit Weight	12 lb (5.4 kg) (with rechargeable battery) 5.3 lb (2.4 kg) (without rechargeable battery)
Battery Type	1 x 12V / 7.5 Ah rechargeable battery
Battery Life / Fully Charge	*Run up to 90 minutes with normal use ^Continuous use up to 30 minutes
Depth rating	5 m / 15 ft
Speed	Up to 2.0 mph (3.2 km/h)

-AQUA RANGER-

Unit Dimensions	11.77 inches x 11.10 inches x 20.5 inches (299 mm x 282 mm x 520 mm)
Unit Weight	11.5 lb (5.2 kg) (with rechargeable battery) 6.3 lb (2.85 kg) (without rechargeable battery)
Battery Type	1 x 12V / 7.5Ah rechargeable battery
Battery Life / Fully Charge	*Run up to 60 minutes with normal use ^Continuous use up to 30 minutes
Depth rating	10 m / 30 ft
Speed	Up to 2.5 mph (4.0 km/h)

*Normal Use

The definition of normal use is based on the average general time of use the user activates the seascooter in the water

^Continuous Use

The definition of continuous use is based on a fully charged battery were by the seascooter is used continuously in the water without stopping.

For more information on
Sea-Doo® Seascooter™ Products
(Warranty, Customer Care / Maintenance,
Parts & Battery Purchase)

PLEASE VISIT
www.seadooseascooter.com

Designed and manufactured by **Stallion sport** LTD.
Block F, 6/F, Wah Hing Industrial Mansions
36 Tai Yau Street, San Po Kong, Kowloon, Hong Kong

Please visit our website at www.seadooseascooter.com to find out your local distributor.

Products covered by the following patents:

USA, Canada, EU, Australia, Japan, Hong Kong, China & Turkey
US D471,506S / US D518,768S / D527,702S / US D506,176S / US D507,776S
D512,678S / D519,911S / 6848385 B2 / US 7000559 B2 / US 7093554 B1 / 11/102,302
0500577.8 / 0500578.0 / 0500579.2 / HK1072691 / ZL200530005661.5
ZL200430079550.4 / ZL200430057359.X / ZL200530005662.X / ZL200530005663.4
ZL200320103738.8 / ZL200520008894.5 / 1194933 / 1254107 / 1225250
000330311-0001 / 000183900-0001 / 000183900-0002 / 000330279-0001
000330295-0001 / 03020902.7 / 302949 / 302564 / 302563 / 302950
302948 / 2005100230 / 200503474 / 29/268,724 / 11/595,675 / 000816376-0001

Toll Free: 1-877-2650996
service@stallionsport.com
www.stallionsport.com



SEA-DOO® and the BRP logo are trademarks of Bombardier Recreational Products Inc. or its affiliates, used under licence to Stallion sport Ltd.
For more information on SEA-DOO® products visit www.sea-doo.com



Patented Print in China

This warranty does not cover any product that has been subject to misuse negligence or accident, or that has been operated in any way contrary to the operating instructions as specified in the User Manual. This warranty does not apply to any damage to the product that is the result of improper maintenance or to any product that has been altered or modified so as to change its intended use. This warranty does not extend to repairs made necessary by normal wear or by the use of parts or accessories which are either incompatible with the product or adversely affects its operation, performance or durability.

In addition, this warranty does not cover items that experience normal wear and tear.

ALL IMPLIED WARRANTIES ARE LIMITED IN THE DURATION TO THE WARRANTY PERIOD. AND SUCH IMPLIED WARRANTIES INCLUDING MERCHANTABILITY, FITNESS FOR A PARTICULAR PURPOSE, OR OTHERWISE, ARE DISCLAIMED IN THEIR ENTIRETY AFTER THE EXPIRATION OF THE APPROPRIATE WARRANTY PERIOD. THE DISTRIBUTOR'S OBLIGATION UNDER THE WARRANTY IS STRICTLY AND EXCLUSIVELY LIMITED TO THE REPAIR OR REPLACEMENT OF DEFECTIVE PARTS AND RETURN OF THE PRODUCT TO THE CUSTOMER. THE DISTRIBUTOR DOES NOT ASSUME OR AUTHORIZE ANYONE TO ASSUME FOR THEM ANY OTHER OBLIGATION.

THE DISTRIBUTOR ASSUMES NO RESPONSIBILITY FOR INCIDENTAL, CONSEQUENTIAL OR OTHER DAMAGES INCLUDING, BUT NOT LIMITED TO EXPENSE OF RETURNING THE PRODUCT TO THE DISTRIBUTOR, LOSS OF USE OF PRODUCT AND LOSS OF TIME OR INCONVENIENCE.

EXCLUSIONS

BATTERY. This warranty does not include the battery.

CUSTOMER ENQUIRIES

If your unit is not operating, please refer to your User Manual before contacting our Customer Service Centre. For any damage or repair work required, please do not return your product to the store where it was purchased.

RETURN / REPAIR POLICY

Customers must call our Customer Service Centre and ask for a Return / Repair Authorization Number before sending the product to the Service Centre. Returned products must be shipped with original packaging including the polystyrene packing material and all defective parts. Please contact our Customer Service Centre for assistance in handling your case.

UNITED STATES SEA-DOO® SEASCOOTER™ CUSTOMER SERVICE CENTRE

Phone No.: +1-800-361-2781 Email: warranty-usa@seadooseascooter.com

CANADA SEA-DOO® SEASCOOTER™ CUSTOMER SERVICE CENTRE

Phone No.: +1-888-388-8837 Email: warranty-can@seadooseascooter.com

WESTERN EUROPE SEA-DOO® SEASCOOTER™ CUSTOMER SERVICE CENTRE

Phone No.: +44 (0)1709 515157 Email: johnc@alphad.org

EASTERN, SOUTHERN AND CENTRAL EUROPE SEA-DOO® SEASCOOTER™ CUSTOMER SERVICE CENTRE

Phone No.: +386 5616 50 20 Email: service@kernsport.com

HONG KONG SEA-DOO® SEASCOOTER™ CUSTOMER SERVICE CENTRE

Phone No.: +852 3516 2388 Email: service@stallionasia.com

(For other territories, please visit www.seadooseascooter.com and contact your local distributor)

RETURN / REPAIR PROCEDURE

1. Call the Customer Service Centre for your Return / Repair Authorization Number.
2. Make a copy of your Proof of Purchase (receipt).
3. Pack the defective unit in its original packaging including the polystyrene foam and include the unit and all defective parts.
4. Attach the copy of your Proof of Purchase (receipt) to the outside of the box (clearly visible), together with the Return / Repair Authorization Number.
5. Ship the package to the Service Centre.

PLEASE NOTE: Deliveries that do not have the Proof of Purchase (receipt) and Return / Repair Authorization Number attached clearly to the outside of the box, will not be accepted by the Service Centre.

For any questions or queries you may have regarding your SEA-DOO® SEASCOOTER™, please follow the below steps for easy and fast resolution:

- STEP 1-

Please read your User Manual. For a copy of the User Manuals, please visit www.seadooseascooter.com

- STEP 2-

Go to www.seadooseascooter.com and see our FAQ section to find instant answers.

- STEP 3-

Contact one of our Customer Service representatives at the Customer Service Centre in your region.