

**Oregon**  
SCIENTIFIC

**Weather@Home  
Bluetooth-enabled  
Weather Station**

---

**USER MANUAL**



BAR218HGX



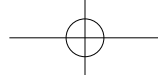

EN

**Weather@Home**  
**Bluetooth-enabled Weather Station**  
**Model: BAR218HGX**  
 User Manual

**TABLE OF CONTENT**

**Introduction**-----3

**Overview**-----3

Front view-----3

Rear view-----4

Remote sensor (THGR511)-----4

**Getting started**-----5

Insert batteries-----5

**Remote sensor**-----5

Sensor data transmission-----5

**Clock**-----6

Manually set clock-----6

**Weather forecast**-----6

**Weather warning message**-----6

**Temperature and humidity**-----6

Ice warning-----7

Weather trends-----7

**Moon phase**-----7

**Backlight**-----7

**Reset**-----7

**Connect with your mobile device**-----8

Pairing your weather station-----8

Settings-----9

View current readings-----10

View history readings-----10

**Precautions**-----11

**Specifications**-----12

**About Oregon Scientific**-----12

**Eu-Declaration of conformity**-----12

**Disposal Information for Users**-----13

**FCC & IC statement**-----13

Declaration of conformity-----14

## INTRODUCTION

Thank you for selecting our Oregon Scientific™ Weather@Home Bluetooth-enabled Weather Station. In addition, it is also carried out the changeable display between indoor and outdoor temperatures.

**NOTE** Please keep this manual handy as you use your new product. It contains practical step-by-step instructions, as well as technical specifications and warnings you should know about.

## OVERVIEW

### FRONT VIEW

1. Remote sensor reception indicator and outdoor channel selected
2. : Outdoor remote sensor battery low
3. : Next 12 hour Weather forecast and pressure trend
4. : weather warning message
5. Indoor temperature reading (current/**MAX**/**MIN**) with temperature trend
6. : BLE connection indicator
7. : Main unit battery low
8. Ice alert LED indicator
9. **MODE**: Change settings / display
10. **MEM**: View current, maximum and minimum temperature / humidity
11. **LIGHT**: Activate backlight
12. / : Increase / decrease value of the settings; toggle only button to select outdoor channels (1-5); activate / deactivate pairing mode.
13. **AM/PM**: Morning/afternoon

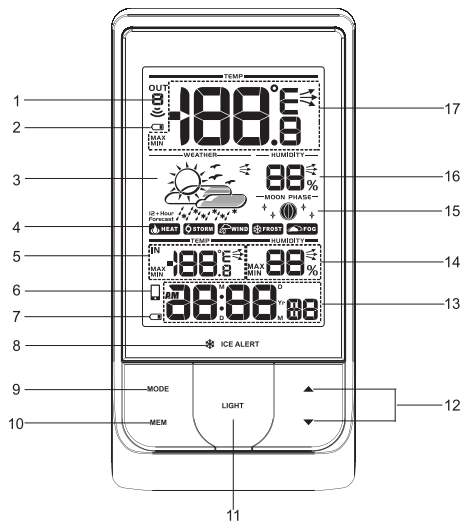

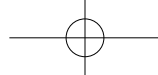

**MD/DM/Yr:** Calendar / clock with weekday (hour : minute with second display)

14. Indoor humidity reading (current / **MAX** / **MIN**) with humidity trend
15. Moon phase display
16. Outdoor humidity (current / **MAX** / **MIN**) with humidity trend
17. Outdoor temperature reading (current / **MAX** / **MIN**) with temperature trend

#### REAR VIEW

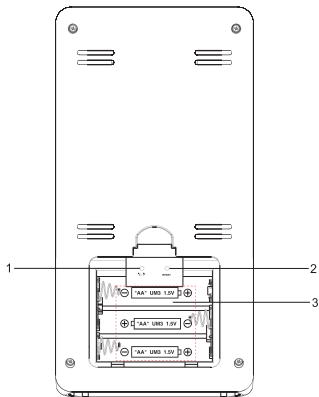

1. °C / °F: Select temperature unit
2. **RESET**: Reset the unit to default settings
3. Battery compartment

#### REMOTE SENSOR (THGR511)

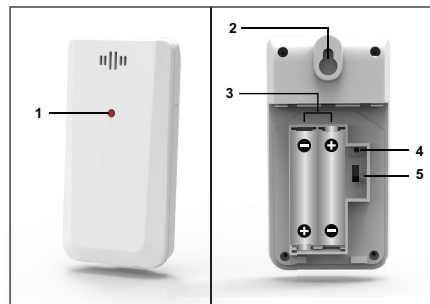

1. LED status indicator
2. Wall mount hole
3. Battery compartment
4. **RESET** hole
5. **CHANNEL** switch

## GETTING STARTED

### INSERT BATTERIES

1. Remove the battery compartment.
2. Insert the batteries, matching the polarities (+/-).
3. Press **RESET** after each battery change.

 LOCATION	MEANING
Clock / alarm area	Main unit batteries low
Outdoor temperature area	Sensor batteries low

### REMOTE SENSOR

The main unit can collect data from up to 5 sensors.

#### To set up the sensor:

1. Open the battery compartment.
2. Select a channel then press **RESET**.
3. Close the battery door.
4. Place the sensor within 98 ft (30 m) of the main unit using the table stand or wall mount.

**TIP** Ideal placements for the sensor would be in any location on the exterior of the home at a height of not more than 5 ft (1.5 m) and which can shield it from direct sunlight or wet conditions for an accurate reading.

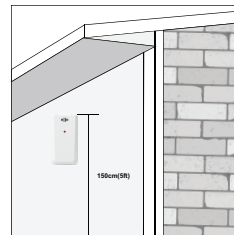



**NOTE** Use alkaline batteries for longer usage and consumer grade lithium batteries in temperatures below freezing.

### SENSOR DATA TRANSMISSION

#### To search for a sensor:

Press and hold **▲** and **MODE** at a time.

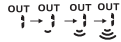
The sensor reception icon in the remote sensor area shows the status:

ICON	DESCRIPTION
	Main unit is searching for sensor(s).
	A channel has been found.
	The sensor cannot be found.

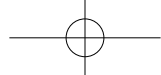

**TIP** The transmission range may vary depending on many factors. You may need to experiment with various locations to get the best results.

## CLOCK

### MANUALLY SET CLOCK

1. Press and hold **MODE**.
2. Press **▲** or **▼** to change the settings.
3. Press **MODE** to confirm.
4. The settings order is: 12/24 hour format, hour, minute, year, calendar format (day-month / month-day), month, day and language.

The language options are English (**E**), German (**D**), French (**F**), Italian (**I**), and Spanish (**S**).

#### To select display mode:

Toggle **MODE** to choose among clock with seconds / weekday / calendar / moon phase.

## WEATHER FORECAST

This product forecasts the next 12 hours of weather within a 19-31 mile (30-50 km) radius.

	Sunny
	Partially Cloudy

	Cloudy
	Rainy
	Snowy

## WEATHER WARNING MESSAGE

The weather warning messages provide indications of probable circumstances that may arise based on the weather station's calculations. The meanings for the warnings are illustrated below:

WARNING	MESSAGE
<b>HEAT</b>	Risk of high temperatures
<b>WIND</b>	Risk of fast wind speeds
<b>STORM</b>	Risk of a storm
<b>FOG</b>	Risk of foggy conditions
<b>FROST</b>	Risk of icy conditions

## TEMPERATURE AND HUMIDITY

#### To select temperature unit:

- Select **°C** or **°F** for temperature readings by a pin or the top of a pen.

**To select an outdoor sensor's readings:**

- Toggle ▲ to select your desired sensor reading.

**To auto-scan among sensors:**

- Press and hold ▼ and MEM at a time to display each sensor's data for 3 seconds.
- To end, press ▲.

**To display current, minimum and maximum records of the data from a selected sensor:**

- Toggle MEM.

**To clear the records:**

- Press and hold MEM.

**ICE WARNING**

If the channel 1 sensor falls from 37°F to 28°F (3°C to -2°C), LED indicator will flash, and will stop flashing once the temperature is out of this range.

- Press ▲ and ▼ at the same time to disable the ice alert warning.

**NOTE** As ice alert is only applicable to channel 1, to prevent flashing of LED, select channel 2 or 3 on outdoor sensor.









**WEATHER TRENDS**

The temperature, humidity and pressure trend icons are based on recent sensor readings.

RISE	STEADY	FALL
		

**MOON PHASE**

In moon phase mode, press ▲ or ▼ to scan through the years (2001 to 2099).

	New moon		Full moon
	Waxing crescent		Waning gibbous
	First quarter		Third quarter
	Waxing gibbous		Waning crescent

**NOTE** Star icons around the moon phase will be displayed from 6 o'clock in the evening to 6 o'clock the next morning.

**BACKLIGHT**

Press LIGHT to activate backlight for 5 seconds.

**RESET**

Press RESET to return to the default settings.



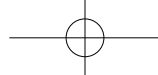

## CONNECT WITH YOUR MOBILE DEVICE

You can remotely set the weather station and read the weather information through Bluetooth® 4.0 using your mobile device with the downloaded application from the Apple Store and the Google Play Store. To quickly find the application, type **'Weather@Home'** as keyword in the search engine.



Ensure your mobile device is compatible with iOS 8 or Android 4.4 with Bluetooth® 4.0.

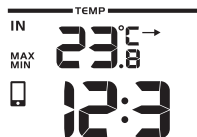

## PAIRING YOUR WEATHER STATION

First of all, you need to pair your weather station with your mobile device.  will flash on the screen of the weather station while pairing and be on after successful pairing.



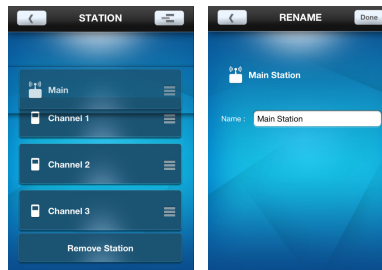

Press and hold  to enable a pair-up for the main unit for 30 seconds.



1. Open the App, tap **Connect**. It will search the weather station automatically.
2. Once the pairing is successful, the station and channel numbers will display.
3. Tap on each channel to rename it. (Up to 20 characters including space are allowed). Tap  if completed. Tap  to exit.

**To remove the weather station:**  
Tap **Remove Station** on **STATION** screen, the weather station will be unpaired and its data will be removed from the App.

### To reposition the sensors on screen:

1. On **STATION** screen, tap .
2. Press and hold  at the right side of a sensor. Drag it to your desired position.
3. Tap  to confirm.



## SETTINGS



You can set your weather station through the application, such as measurement units.

### The settings are as follows:

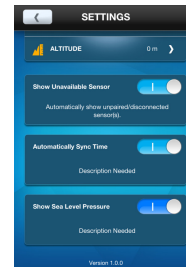
- Temperature
- Barometric
- Rainfall (not available in BAR218HGX)
- Wind speed (not available in BAR218HGX)
- Altitude
- Show Unavailable Sensor
- Automatically Sync Time
- Show Sea Level Pressure



### To select the measurement unit:

1. Tap  to view the measurement unit options.
2. Tap on your desired unit.
3. Tap  to go back to the previous screen.

### To set altitude:

The altitude reflects the distance from sea level at your position.

1. Fill in the altitude of your main unit in the blank.
2. Tap **Done**.

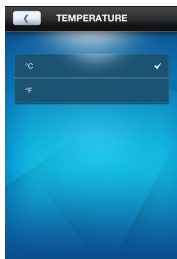
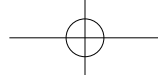

### VIEW CURRENT READINGS

You can directly view all the weather readings from different sensors through the application at a time. The readings are in **HOME** screen.

**NOTE** If low battery icon  displays on the screen, please replace the batteries for the corresponding device.

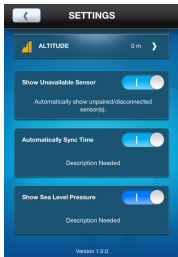

### To show unavailable sensor:

If the sensor is out of range, the readings are interrupted and — (dash mode) displays on the screen. If you do not want to show the unavailable sensor:

- On **SETTINGS** screen, touch and slide the button to right to turn on the function, or sliding to left to turn it off.

### To automatically synchronize time:

Time and date on your weather station could be automatically synchronized by your mobile device.

- On **SETTINGS** screen, touch and slide the button to right to turn on the function, or sliding to left to turn it off.

### To show sea level pressure:

After the altitude is input, you can view the sea level pressure on the **HOME** screen.







- On **SETTINGS** screen, touch and slide the button to right to turn on the function, or sliding to left to turn it off.

**NOTE** When altitude is set to 0 meter, the pressure reading is the local pressure. If the altitude is set to the current location, the new pressure reading will be displayed as a sea level pressure.

### VIEW HISTORY READINGS

You can view history through the application. The history could also be presented in graphs (past 24 hours or past 7 days).

### To view the history:

1. Tap on your desired sensor area on the screen.
2. Tap    to select your desired data or tap  to sort the data by date.



## PRECAUTIONS

- Do not subject the unit to excessive force, shock, dust, temperature or humidity.
- Do not cover the ventilation holes with any items such as newspapers, curtains etc.
- Do not immerse the unit in water. If you spill liquid over it, dry it immediately with a soft, lint-free cloth.
- Do not clean the unit with abrasive or corrosive materials.

- Do not tamper with the unit's internal components. This invalidates the warranty.
- Only use fresh batteries. Do not mix new and old batteries.
- Images shown in this manual may differ from the actual display.
- When disposing of this product, ensure it is collected separately for special treatment and not as household waste.
- Placement of this product on certain types of wood may result in damage to its finish for which Oregon Scientific will not be responsible. Consult the furniture manufacturer's care instructions for information.
- The contents of this manual may not be reproduced without the permission of the manufacturer.
- Do not dispose old batteries as unsorted municipal waste. Collection of such waste separately for special treatment is necessary.
- Please note that some units are equipped with a battery safety strip. Remove the strip from the battery compartment before first use.

**NOTE** The technical specifications for this product and the contents of the user manual are subject to change without notice. To download an electronic version of the user manual, please visit <http://global.oregonscientific.com/customerSupport.php>.

**NOTE** Features and accessories will not be available in all countries. For more information, please contact your local retailer.

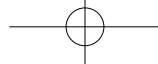
**SPECIFICATIONS**

TYPE	DESCRIPTION
<b>MAIN UNIT</b>	
L x W x H	7.32 x3.7 x 2.13 in 186 x 94 x 54 mm
Weight	223 g without battery
Temperature range	-5°C to 50°C (23°F to 122°F)
Signal frequency	433 MHz
Humidity range	25% - 95%
Power	3 x UM-3 (AA) 1.5V batteries
Temperature range for ice alert	3°C to -2°C
<b>REMOTE UNIT (THGR511)</b>	
L x W x H	96 x 50 x 22 mm (3.78 x 1.97 x 0.87 in)
Weight	49 g (1.7 ounces)
Transmission range	30 m (98 ft) unobstructed
Temperature range	-20°C to 60°C (-4°F to 140°F)
Power	2 x UM-4 (AAA) 1.5 V batteries

**ABOUT OREGON SCIENTIFIC**

Visit our website [www.oregonscientific.com](http://www.oregonscientific.com) to learn more about Oregon Scientific products.

For any inquiry, please contact our Customer Services at [info@oregonscientific.com](mailto:info@oregonscientific.com).

Oregon Scientific Global Distribution Limited reserves the right to interpret and construe any contents, terms and provisions in this user manual and to amend it, at its sole discretion, at any time without prior notice. To the extent that there is any inconsistency between the English version and any other language versions, the English version shall prevail.

**EU-DECLARATION OF CONFORMITY**

Hereby the manufacturer, Oregon Scientific Global Distribution Limited, declares that the radio equipment type Weather@Home Bluetooth-enabled Weather Station (Model: BAR218HGX) is in compliance with 2014/53/EU Directive. The full text of the EU Declaration of Conformity is available at the following internet address:

<http://global.oregonscientific.com/customerSupport.php>

**COUNTRIES RED APPROVED COMPLIED**All EU countries, Switzerland and Norway 

## DISPOSAL INFORMATION FOR USERS



Pursuant to and in accordance with Article 14 of the Directive 2012/19/EU of the European Parliament on waste electrical and electronic equipment (WEEE), and pursuant to and in accordance with Article 20 of the Directive 2013/56/EU of the European Parliament on batteries and accumulators and waste batteries.

The barred symbol of the rubbish bin shown on the equipment indicates that, at the end of its useful life, the product must be collected separately from other waste.

Please note that the batteries/rechargeable batteries must be removed from the equipment before it is given as waste. To remove the batteries/accumulators refer to the specifications in the user manual. Therefore, any products that have reached the end of their useful life must be given to waste disposal centers specializing in separate collection of waste electrical and electronic equipment, or given back to the dealer when purchasing a new WEEE, pursuant to and in accordance with Article 14 as implemented in the country.

The adequate separate collection for the subsequent start-up of the equipment sent to be recycled, treated and disposal of in an environmentally compatible way contributes to preventing possible negative effects on the environment and health and optimizes the recycling and reuse of components making up the apparatus.

Abusive disposal of the product by the user involves application of the administrative sanctions according to the laws in force.

## FCC STATEMENT

This device complies with Part 15 of the FCC Rules. Operation is subject to the following two conditions: (1) This device may not cause harmful interference, and (2) This device must accept any interference received, including interference that may cause undesired operation.

**WARNING** Changes or modifications to this unit not expressly approved by the party responsible for compliance could void the user's authority to operate the equipment.

**NOTE** This equipment has been tested and found to comply with the limits for a Class B digital device, pursuant to Part 15 of the FCC Rules. These limits are designed to provide reasonable protection against harmful interference in a residential installation.

This equipment generates, uses and can radiate radio frequency energy and, if not installed and used in accordance with the instructions, may cause harmful interference to radio communications. However, there is no guarantee that interference will not occur in a particular installation. If this equipment does cause harmful interference to radio or television reception,

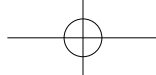

EN

which can be determined by turning the equipment off and on, the user is encouraged to try to correct the interference by one or more of the following measures:

- Reorient or relocate the receiving antenna.
- Increase the separation between the equipment and receiver.
- Connect the equipment into an outlet on a circuit different from that to which the receiver is connected.
- Consult the dealer or an experienced radio / TV technician for help.

### DECLARATION OF CONFORMITY

The following information is not to be used as contact for support or sales. Please call our customer service number (listed on our website at [www.oregonscientific.com](http://www.oregonscientific.com)), or on the warranty card for this product) for all inquiries instead.

#### We

Name: Oregon Scientific Inc.  
 Address: Brea Corporate Park  
 3020 Saturn St. Suite 200  
 Brea, CA 92821  
 Telephone No.: 1 (888) 950-8889

#### declare that the product

Product No.: BAR218HGX  
 Product Name: Weather@Home  
 Bluetooth-enabled Weather Station  
 Manufacturer: Oregon Scientific  
 Global Distribution Limited  
 Address: Block C, 9/F, Kaiser Estate,  
 Phase 1, 41 Man Yue St.,  
 Hung Hom, Kowloon,  
 Hong Kong

is in conformity with Part 15 of the FCC Rules. Operation is subject to the following two conditions: 1) This device may not cause harmful interference. 2) This device must accept any interference received, including interference that may cause undesired operation.





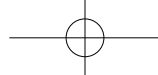

**Weather@Home**  
**Stazione meteorologica con connessione**  
**Bluetooth**  
**Model: BAR218HGX**

Manuale utente

**INDICE**

<b>Introduzione</b> .....	<b>2</b>
<b>Panoramica</b> .....	<b>2</b>
Vista anteriore .....	2
Vista posteriore .....	3
Sensore remoto .....	3
<b>Come iniziare</b> .....	<b>4</b>
Inserire le batterie .....	4
<b>Sensore remoto</b> .....	<b>4</b>
Trasmissione dati del sensore .....	5
<b>Orologio</b> .....	<b>5</b>
Impostazione manuale dell'orologio .....	5
<b>Previsioni del tempo</b> .....	<b>5</b>
<b>Messaggio avviso meteo</b> .....	<b>5</b>
<b>Temperatura e umidità</b> .....	<b>6</b>
Allarme gelo .....	6
Tendenze atmosferiche .....	6

<b>Fase lunare</b> .....	<b>6</b>
<b>Retroilluminazione</b> .....	<b>7</b>
<b>Reset (Ripristino)</b> .....	<b>7</b>
<b>Collegamento al vostro Dispositivo mobile</b> .....	<b>7</b>
Sincronizzazione della vostra Stazione meteo .....	7
Impostazioni .....	8
Visualizzazione dei dati attuali .....	9
Visualizzazione dello storico dei dati .....	10
<b>Precauzioni</b> .....	<b>11</b>
<b>Specifiche</b> .....	<b>12</b>
<b>Informazioni su Oregon Scientific</b> .....	<b>12</b>
<b>Dichiarazione di conformità ue</b> .....	<b>12</b>
<b>Informazione Agli Utenti</b> .....	<b>13</b>

## INTRODUZIONE

Grazie per aver scelto il nostro Oregon Scientific Weather@Home Stazione meteorologica con connessione Bluetooth e indicazione della temperatura interna ed esterna.

**NOTA** Si consiglia di tenere questo manuale a portata di mano durante l'utilizzo del prodotto. Il manuale contiene pratiche istruzioni dettagliate, dati tecnici e avvertenze che è necessario conoscere.

## PANORAMICA

### VISTA ANTERIORE

1. Indicatore ricezione sensore remoto e canale esterno selezionato
2. : batteria scarica del sensore remoto esterno
3. **12+ Hour Forecast**: Previsioni meteorologiche per le prossime 12 ore e tendenza pressione
4. : messaggio avviso meteo
5. Visualizzazione temperatura interna (corrente/ **MAX/MIN**) con andamento temperature
6. Indicatore connessione Bluetooth
7. : batteria scarica unità principale
8. Indicatore LED per allarme ghiaccio

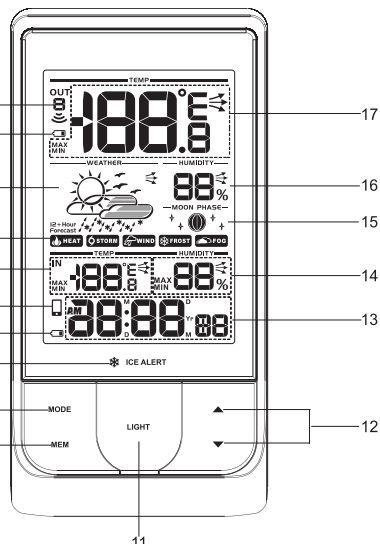

9. **MODE**(MODALITÀ): modifica impostazioni / visualizzazione
10. **MEM**: visualizzazione valori attuali, massimi e minimi di temperatura / umidità



11. **LIGHT (LUCE)**: attivazione retroilluminazione
12. ▲ / ▼: aumento / diminuzione valore delle impostazioni; selezionare canali esterni (1-5); attivazione / disattivazione **MODE (MODALITÀ)** di accoppiamento.
13. **AM/PM**: mattina/pomeriggio.  
**MM-GG / GG-MM / AA**: calendario / orologio con giorno della settimana (ora: minuti con visualizzazione secondi)
14. Visualizzazione umidità interna (valori attuali/**MAX/MIN**) con andamento umidità
15. Visualizzazione fase lunare
16. Visualizzazione umidità esterna (valori attuali/**MAX/MIN**) con andamento umidità
17. Visualizzazione temperatura esterna (corrente/**MAX/MIN**) con andamento temperatura

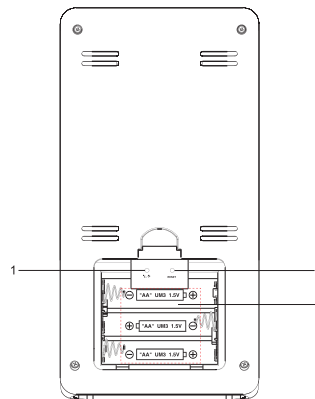

#### VISTA POSTERIORE

1. °C / °F: selezionare unità di misura temperatura
2. **RESET (RIPRISTINO)**: ripristino dell'unità alle impostazioni di default
3. Compartimento batterie

#### SENSORE REMOTO

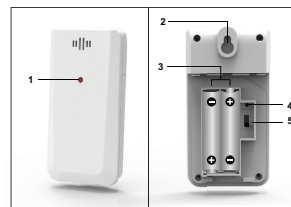

1. Indicatore LED di stato
2. Foro per fissaggio a parete
3. Vano batterie
4. Foro **RESET**
5. Selettore **CHANNEL**

## COME INIZIARE

### INSERIRE LE BATTERIE

1. Rimuovere il compartimento batterie.
2. Inserire le batterie, rispettando le polarità (+/-).
3. Premere **RESET** (RIPRISTINO) dopo ogni sostituzione di batterie

 UBICAZIONE	SIGNIFICAT
Area orologio / sveglia	Batterie scariche unità principale
Area temperatura esterna	Batterie sensore scariche

### SENSORE REMOTO

L'unità principale può raccogliere dati da fino a 5 sensori.

#### Per impostare il sensore:

1. Aprire il compartimento batterie.
2. Selezionare un canale quindi premere **RESET** (RIPRISTINO).

3. Chiudere il coperchio delle batterie.
4. Mettere il sensore entro 98 piedi (30 m) dall'unità principale usando il supporto da tavolo oppure il montaggio a parete.

**TIP** La posizione ideale per il sensore sarebbe qualsiasi posizione all'esterno della casa ad un'altezza non superiore a 5 piedi (1,5 m) ed al riparo dalla luce solare diretta o dall'umidità per una lettura accurata.

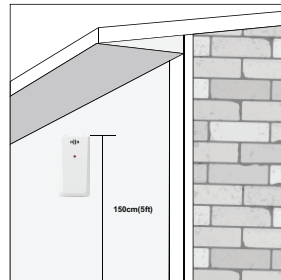

**NOTA** Usare batterie alcaline per un funzionamento più lungo e batterie al litio d'uso comune per temperature al di sotto del punto di congelamento.

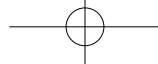

## TRASMISSIONE DATI DEL SENSORE

### Come ricercare un sensore:

Premere e tener premuto **▲** e **MODE** (MODALITÀ) contemporaneamente.

**L'icona di ricezione del sensore nell'area del sensore remoto mostra lo stato:**

ICONA	DESCRIZIONE
	L'unità principale sta cercando il(i) sensore(i).
	È stato trovato un canale.
	Non si trova il sensore.

**TIP** La portata di trasmissione può variare in dipendenza di molti fattori. Potreste dover provare con diverse posizioni per ottenere i risultati migliori.

## OROLOGIO

### IMPOSTAZIONE MANUALE DELL'OROLOGIO

1. Premere e tener premuto **MODE** (MODALITÀ).
2. Premere **▲** oppure **▼** per cambiare le impostazioni.
3. Premere **MODE** (MODALITÀ) per confermare.
4. L'ordine delle impostazioni è: formato ora 12/24, ora, minuti, anno, formato calendario (giorno-mese / mese-giorno), mese, giorno e lingua.

Le opzioni della lingua sono Inglese (**E**), Tedesco (**D**), Francese (**F**), Italiano (**I**), e Spagnolo (**S**).

### Per selezionare **MODE** (MODALITÀ) di visualizzazione:

Azionare **MODE** (MODALITÀ) per scegliere tra orologio con secondi / giorno della settimana / calendario / fase lunare.

## PREVISIONI DEL TEMPO

Questo prodotto fornisce le previsioni del tempo per le successive 12 ore, entro un raggio di 19-31 miglia (30-50 km).

	Soleggiato
	Parzialmente nuvoloso
	Nuvoloso
	Piovoso
	Nevoso

## MESSAGGIO AVVISO METEO

I messaggi di avviso meteo forniscono indicazioni di probabili circostanze che possono sorgere sulla base dei calcoli della stazione meteo. I significati degli avvisi sono illustrati di seguito:

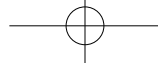

E

AVVISO	MESSAGGIO
HEAT	Rischio di alte temperature
WIND	Rischio di venti ad alta velocità
STORM	Rischio di una tempesta
FOG	Rischio di nebbia
FROST	Rischio di ghiaccio

## TEMPERATURA E UMIDITÀ

### Selezionare unità di misura temperatura:

- Selezionare °C oppure °F per lettura temperature usando uno spillo o la punta di una penna.

### Per selezionare le letture di un sensore esterno:

- Azionare ▲ per selezionare la lettura del sensore desiderato.

### Per fare una scansione automatica dei sensori:

- Premere e tener premuto ▼ e MEM contemporaneamente per visualizzare i dati di ogni sensore per 3 secondi.
- Per terminare premere ▲.

### Per visualizzare le registrazioni correnti, minime e massime del giorno di un sensore selezionato:

- Azionare MEM.

### Per cancellare le registrazioni:

- Premere e tener premuto MEM.

## ALLARME GELO

Se il sensore del canale 1 scende da 37°F a 28°F (da 3°C a -2°C), l'indicatore LED lampeggerà; l'indicatore smetterà di lampeggiare una volta che la temperatura esce da quell'intervallo.

- Premere contemporaneamente ▲ e ▼ per disarmare l'avviso di allarme ghiaccio.

**NOTA** Poiché l'allarme ghiaccio si applica solo al canale 1, per impedire il lampeggiamento del LED, selezionare il canale 2 o 3 per un sensore esterno.

## TENDENZE ATMOSFERICHE







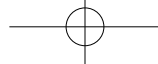

Le icone delle tendenze della temperatura, umidità e pressione sono basate sulle letture recenti del sensore.

IN AUMENTO	STABILE	IN DIMINUZIONE

## FASE LUNARE

Selezionare **MODE** (Modalità) fino ad accedere alla funzione FASE LUNARE; premere ▲ oppure ▼ per scorrere velocemente gli anni (dal 2001 al 2099).



	Luna nuova		Luna piena
	Falce di luna crescente		Luna gibbosa calante
	Primo quarto		Ultimo quarto
	Luna gibbosa crescente		Falce di luna calante

**NOTA** Le icone delle stelle intorno alla fase lunare saranno visualizzate dalle 6 della sera alle 6 del mattino successivo.

## RETROILLUMINAZIONE

Premere **LIGHT** (LUCE) per attivare la retroilluminazione per 5 secondi.

## RESET (RIPRISTINO)

Premere **RESET** (RIPRISTINO) per ritornare alle impostazioni di default.

## COLLEGAMENTO AL VOSTRO DISPOSITIVO MOBILE

Potete impostare da remoto la vostra stazione meteo e leggere le informazioni sul tempo via Bluetooth® 4.0 usando il vostro dispositivo mobile e scaricando l'applicazione da Apple Store e Google Play Store. Per trovare rapidamente l'applicazione scrivete

'**Weather@Home**' come parola chiave nel motore di ricerca.

Assicuratevi che il vostro dispositivo mobile sia compatibile con iOS 8 oppure Android 4,4 con Bluetooth® 4,0.

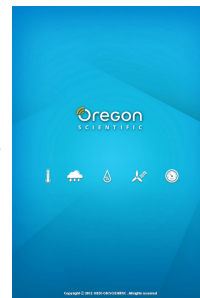

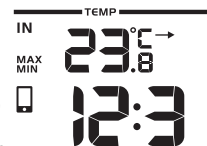

## SINCRONIZZAZIONE DELLA VOSTRA STAZIONE METEO

Prima di tutto dovete sincronizzare la vostra stazione meteo con il vostro dispositivo mobile. Il simbolo  lampeggerà sullo schermo della stazione meteo mentre la sincronizzazione è in corso e resterà acceso dopo che la sincronizzazione è terminata.

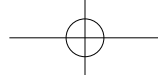

Premere **▲** per 30 secondi al fine di effettuare la sincronizzazione con l'unità principale.





1. Apri l'app, tocca **Connetti**. Cercherà automaticamente la stazione meteorologica.
2. Una volta completata l'associazione, verranno visualizzati i numeri della stazione e del canale.
3. Fare clic su ogni canale per rinominarlo (sono consentiti fino a 20 caratteri compresi gli spazi). Fare clic su **Done** se si ha terminato. Fare clic su  per uscire.

#### Per rimuovere la stazione meteo:

Cliccate su **Remove Station** (Rimuovere stazione) sullo schermo **STATION** (STAZIONE), la stazione meteo non sarà più collegata all'App ed i dati non saranno più visibili su di essa.

#### Per riposizionare i sensori sullo schermo:

1. Sullo schermo **STATION** (STAZIONE), cliccate su .
2. Premere e tenere premuto su  sul lato destro di un sensore. Trascinatelo nella posizione desiderata.
3. Cliccate su  per confermare.



## IMPOSTAZIONI

Potete impostare la vostra stazione meteo tramite l'applicazione, come per esempio le unità di misura.



#### Le impostazioni sono le seguenti:

- Temperatura
- Barometro
- Piovosità (non disponibile in BAR218HGX)
- Velocità del vento (non disponibile in BAR218HGX)
- Altitudine
- Mostra sensori non disponibili
- Sincronizzazione automatica dell'ora
- Mostra pressione a livello del mare

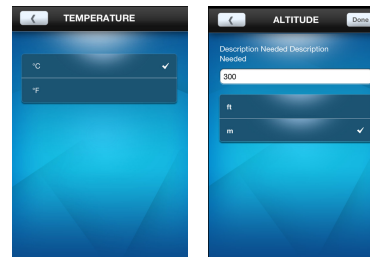
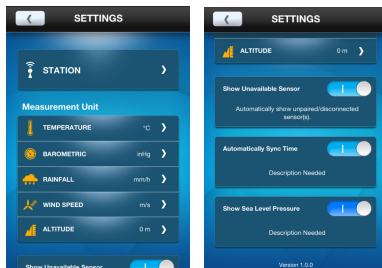
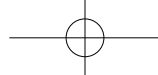



### Per selezionare l'unità di misura:

1. Cliccare su  per visualizzare le opzioni delle unità di misura.
2. Cliccate sull'unità di misura desiderata.
3. Cliccate su  per tornare allo schermo precedente.

### Per impostare l'altitudine:

L'altitudine rispecchia la distanza dal livello del mare alla vostra posizione.

1. Immettere l'altitudine della vostra unità principale nello spazio vuoto.
2. Cliccate su **Done** (Completato).

### VISUALIZZAZIONE DEI DATI ATTUALI

Direttamente dall'applicazione, potete visualizzare contemporaneamente tutti i dati rilevati dai sensori remoti. I dati vengono visualizzati sulla **HOME** (principale).

**NOTA** Se l'icona di batterie scariche  appare sullo schermo, sostituite le batterie per il dispositivo corrispondente.

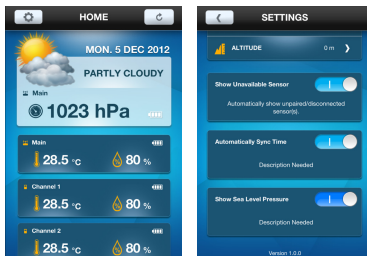
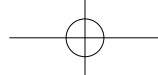

#### Per visualizzare il sensore non disponibile:

Se il sensore è fuori portata le letture sono interrotte e lo schermo va in **MODE** (MODALITÀ) trattini — Se non volete mostrare il sensore non disponibile:

- Sullo schermo **SETTINGS** (IMPOSTAZIONI), toccate e fate scorrere verso destra il tasto per attivare la funzione oppure verso sinistra per disattivarla.

#### Per sincronizzare l'ora automaticamente:

Data e ora sulla tua stazione meteo possono essere sincronizzate automaticamente dal tuo dispositivo mobile.

- Sullo schermo **SETTINGS** (IMPOSTAZIONI), toccate e fate scorrere verso destra il tasto per attivare la funzione oppure verso sinistra per disattivarla.

#### Per mostrare la pressione a livello del mare:

Dopo che avete immesso l'altitudine potete visualizzare la pressione al livello del mare sullo schermo **HOME** (PRINCIPALE).

- Sullo schermo **SETTINGS** (IMPOSTAZIONI), toccate e fate scorrere verso destra il tasto per attivare la funzione oppure verso sinistra per disattivarla.







**NOTA** Quando l'altitudine è impostata a 0 metri, la lettura della pressione è la pressione locale. Se l'altitudine è impostata alla posizione corrente, la nuova lettera della pressione sarà visualizzata come pressione a livello del mare.

#### VISUALIZZAZIONE DELLO STORICO DEI DATI

Potete visualizzare lo storico tramite l'applicazione. Lo storico può anche essere presentato come grafici (le ultime 24 ore o gli ultimi 7 giorni).

#### Per visualizzare lo storico:

1. Cliccate sull'area del sensore desiderato sullo schermo.
2. Cliccate su    per selezione i dati desiderati o cliccate su  per ordinare i dati per data.

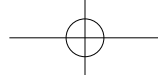

## PRECAUZIONI

- Non sottoporre il prodotto a forza eccessiva, urti, polvere, temperatura o a umidità.
- Non otturare i fori di aerazione con oggetti come giornali, tende, etc.
- Non immergere l'unità in acqua. Se si versa del liquido sul prodotto, asciugarlo immediatamente con un panno morbido e liscio.
- Non pulire l'unità con materiali abrasivi, corrosivi o alcalici.
- Non graffiare il display LCD con oggetti duri in quanto si potrebbero causare danni.
- Non manomettere i componenti interni dell'unità. In questo modo si invalida la garanzia.

- Utilizzare solo batterie nuove. Non mescolare batterie nuove con batterie vecchie.
- Le immagini del manuale possono differire dalla realtà.
- Al momento dello smaltimento del prodotto, conferirlo ai centri di raccolta specifici.
- Decliniamo ogni responsabilità per eventuali danni causati dal posizionamento del prodotto su determinati tipi di legno. Consultare le istruzioni fornite dal fabbricante del mobile per ulteriori informazioni.
- Il contenuto di questo manuale non può essere riprodotto senza l'autorizzazione del fabbricante.
- Non smaltire le batterie vecchie come rifiuto non differenziato. È necessario che questo tipo di rifiuto venga smaltito separatamente per essere trattato in modo specifico.
- Alcune unità sono dotate di una striscia protettiva per le batterie. Rimuoverla dal vano batterie prima dell'utilizzo.

**NOTA** Le specifiche tecniche del prodotto e il contenuto del manuale per l'utente possono essere modificati senza preavviso. Si prega di visitare il sito <http://global.oregonscientific.com/customerSupport.php> per scaricare una versione elettronica del manuale.

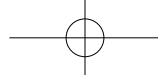

E

**SPECIFICHE**

TIPO	DESCRIZIONE
<b>UNITÀ PRINCIPALE</b>	
L x W x H	7,32 x 3,7 x 2,13 pollici (186 x 94 x 54 mm)
Peso	223 g (7,87once) senza batterie
Intervallo temperature	da -5°C a 50°C (da 23°F a 122°F)
Frequenza segnale	433 MHz
Intervallo umidità	25% - 95%
Alimentazione	3 batterie UM-3 (AA) da 1,5V
Intervallo temperatura per avviso ghiaccio	Da 3°C a -2°C
<b>UNITÀ REMOTA (THGR511)</b>	
L x P x H	96 x 50 x 22 mm
Peso	49 g
Campo di trasmissione	30 m senza ostruzioni
Campo di misurazione della temperatura	da -20°C a 60°C
Alimentazione	2 batterie UM-4 (AAA) da 1,5 V

**INFORMAZIONI SU OREGON SCIENTIFIC**

Per richiedere informazioni, contattate il nostro Servizio Clienti al seguente collegamento:  
<https://www.nital.it/contatti/index.php>.

Oregon Scientific Global Distribution Limited si riserva il diritto di interpretare e definire eventuali contenuti, termini e disposizioni contenuti in questo manuale per l'utente e di modificarli, a sua esclusiva discrezione, in qualsiasi momento e senza preavviso. Nella misura in cui risultassero incongruenze tra la versione in inglese e quelle in altre lingue, farà fede la versione in inglese.

**DICHIARAZIONE DI CONFORMITA'UE**

Con la presente il fabbricante, Oregon Scientific Global Distribution Limited, dichiara che questo tipo di apparecchiatura Weather@Home Stazione meteorologica con connessione Bluetooth (Model: BAR218HGX) è conforme alla direttiva 2014/53/UE. Il testo completo della Dichiarazione di Conformità UE è disponibile al seguente indirizzo internet:  
<http://global.oregonscientific.com/customerSupport.php>



**PAESI CONFORMI ALLA DIRETTIVA RED**  
Tutti i Paesi EU, Svizzera   
e Norvegia 

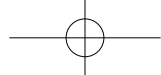

## INFORMAZIONE AGLI UTENTI



**Ai sensi dell'art.26 del Decreto Legislativo 14 marzo 2014, n. 49 "Attuazione della Direttiva 2012/19/UE sui rifiuti di apparecchiature elettriche ed elettroniche (RAEE)" ed ai sensi dell'art.22 del Decreto Legislativo 188 del 20 novembre 2008 "Attuazione della direttiva 2013/56/EU concernente pile, accumulatori e relativi rifiuti".**

Il simbolo del cassonetto barrato riportato sull'apparecchiatura o sulla sua confezione indica che il prodotto alla fine della propria vita utile deve essere raccolto separatamente dagli altri rifiuti per permetterne un adeguato trattamento e riciclo.

Si ricorda che le pile/accumulatori devono essere rimosse dall'apparecchiatura prima che questa sia conferita come rifiuto. Per rimuovere le pile/accumulatori fare riferimento alle specifiche indicazioni riportate nel manuale d'uso.

L'utente dovrà, pertanto, conferire gratuitamente l'apparecchiatura e la pila giunta a fine vita agli idonei centri comunali di raccolta differenziata dei rifiuti elettrici ed elettronici, oppure riconsegnarle al rivenditore secondo le seguenti modalità:

- sia pile portatili sia apparecchiature di piccole dimensioni, ovvero con almeno un lato esterno non superiore a 25 cm, è prevista la consegna gratuita senza obbligo di acquisto presso i negozi con una superficie di vendita delle apparecchiature elettriche

ed elettroniche superiore ai 400 mq. Per negozi con dimensioni inferiori, tale modalità è facoltativa.

- per apparecchiature con dimensioni superiori a 25 cm, è prevista la consegna in tutti i punti di vendita in modalità 1 contro 1, ovvero la consegna al rivenditore potrà avvenire solo all'atto dell'acquisto di un nuovo prodotto equivalente, in ragione di uno a uno.

L'adeguata raccolta differenziata per l'avvio successivo dell'apparecchiatura e delle pile/accumulatori dismessi al riciclaggio, al trattamento e allo smaltimento ambientalmente compatibile contribuisce ad evitare possibili effetti negativi sull'ambiente e sulla salute e favorisce il reimpiego e/o riciclo dei materiali di cui essi sono composti.

Lo smaltimento abusivo di apparecchiature, pile ed accumulatori da parte dell'utente comporta l'applicazione delle sanzioni di cui alla corrente normativa di legge.





FR

**Weather@Home**  
**Station météo mobile compatible à Bluetooth**  
**Modèle : BAR218HGX**

Manuel de l'Utilisateur

## TABLE DES MATIÈRES

<b>Introduction</b> .....	2
<b>Vue d'ensemble</b> .....	2
Vue de face.....	2
Vue arrière.....	3
Sonde sans fil.....	3
<b>Comment démarrer</b> .....	3
Insérer les piles .....	3
<b>Sonde sans fil</b> .....	4
Transmission des données de la sonde .....	4
<b>Horloge</b> .....	5
Horloge régler manuellement.....	5
<b>Prévisions météorologiques</b> .....	5
<b>Message d'avertissement de la météo</b> .....	5
<b>Température et humidité</b> .....	6
Avertissement de gel .....	6
Tendances météorologiques.....	6

<b>Phase de la lune</b> .....	6
<b>Backlight (rétroéclairage)</b> .....	7
<b>Réinitialiser</b> .....	7
<b>Connectez-vous à un téléphone mobile</b> .....	7
Appariement de votre station météomobile .....	7
Réglages .....	8
Voir les affichages en cours.....	9
Voir l'historique des affichages .....	10
<b>Précautions</b> .....	10
<b>Spécifications</b> .....	11
<b>À propos d'Oregon Scientific</b> .....	12
<b>Europe - déclaration de conformité</b> .....	12
<b>Informations Aux Usagers</b> .....	13

## INTRODUCTION

Merci d'avoir choisi notre de Oregon Scientific Weather@Home Station météo mobile compatible à Bluetooth. En outre, il est également procédé à l'affichage d'images variables entre les températures intérieure et extérieure.

**REMARQUE** Veuillez conserver ce manuel à portée de main lorsque vous utilisez votre nouveau produit. Il contient des instructions étape par étape instructions, ainsi que les spécifications techniques et avertissements que vous vous devez de connaître.

## VUE D'ENSEMBLE

### VUE DE FACE

1. L'indicateur de réception de la sonde sans fil et le canal extérieur sélectionné
2. : pile faible de la sonde sans fil extérieure
3. **12+ Hour Forecast**: Plus de 12 heures de prévisions météorologiques avec les tendances de pression
4. : Message d'avertissement de la météo
5. Affichage de la température intérieure (en cours/ **MAX/MIN**) avec la tendance de la température
6. Indicateur de connexion BLE
7. : pile faible de l'unité principale
8. Indicateur LED d'alerte du gel

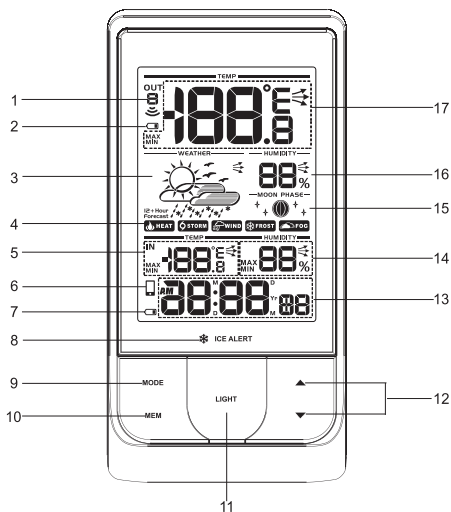

9. **MODE**: réglages de modification / d'affichage
10. **MEM**: voir la température / l'humidité maximale, minimale ou en cours
11. **LIGHT (ECLAIRAGE)**: activer le rétro-éclairage
12. **▲ / ▼**: augmenter/ réduire la valeur du réglage, basculer seulement le bouton pour sélectionner les canaux extérieurs (1-5); activer / désactiver le mode d'appariement.



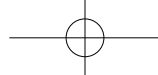

13. **AM/PM** : matin/soir

**MD/DM/Yr**: calendrier / horloge avec les jours de la semaine (heure : minute avec un affichage de seconde)

14. Affichage de l'humidité intérieure (en cours/**MAX/MIN**) avec la tendance de l'humidité

15. Affichage de la phase de la lune

16. Humidité extérieure (en cours/**MAX/MIN**) avec la tendance de l'humidité

17. Affichage de la température extérieure (en cours/**MAX/MIN**) avec tendance de la température

## VUE ARRIERE

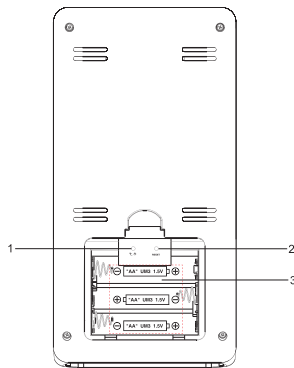

1. °C / °F: Sélectionner une unité de température
2. **RESET** (REINITIALISER): réinitialiser l'appareil aux réglages par défaut.
3. Compartiment des piles

## SONDE SANS FIL

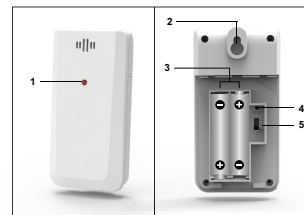

1. Indicateur d'état LED
2. Trou de fixation murale
3. Compartiment des piles
4. Fente **REINITIALISER** (reset)
5. Bouton **CANAL** (channel)

## COMMENT DEMARRER

### INSÉRER LES PILES

1. Retirer le compartiment des piles.
2. Insérer les piles, faire correspondre les polarités (+/-).

3. Appuyer sur **RESET** (REINITIALISER) après chaque changement de pile.

 <b>EMPLACEMENT</b>	<b>SIGNIFICATION</b>
Zone Horloge / Alarme	Pile faible de l'appareil principal
Zone de température extérieure	Piles faibles de la sonde sans fil

### SONDE SANS FIL

L'appareil principal peut collecter les données en provenance de jusqu'à 5 sondes.

#### Régler la sonde:

- Ouvrir le compartiment des piles.
- Sélectionner un canal puis appuyer **RESET** (REINITIALISER).
- Fermer le compartiment des piles.
- Placer la sonde sans fil à 98 pieds (30 m) de l'appareil principal à l'aide d'un support de table ou d'une fixation murale.

**ASTUCE** Les positions indiquées pour la sonde seront dans tout emplacement à l'extérieure de la maison à une hauteur inférieure à 5 pieds (1,5) et qui peut la protéger des rayons directs du soleil ou des conditions humides pour une lecture précise.

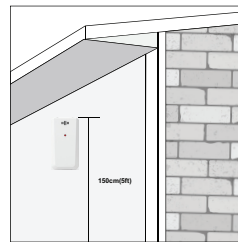



**REMARQUE** Utiliser des piles alcalines pour une plus grande longévité et des piles au lithium pour des températures en dessous de 0°C.

### TRANSMISSION DES DONNEES DE LA SONDE

#### Rechercher une sonde:

Appui prolongé sur **▲** et sur **MODE** au même moment.

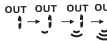
**L'icône de réception de la sonde dans la zone de la sonde sans fil présente l'état:**

<b>ICÔNE</b>	<b>DESCRIPTION</b>
	L'appareil principal recherche le(s) capteur(s).
	Un canal a été trouvé.
	Le capteur est introuvable.

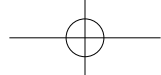

**ASTUCE** La plage de transmission peut varier en fonction de plusieurs facteurs. Vous pourrez avoir besoin d'expérimenter les différents emplacements pour obtenir de meilleurs résultats.

## HORLOGE

### HORLOGE REGLER MANUELLEMENT

1. Appui prolongé sur **MODE**.
2. Appuyer ▲ sur ▼ ou sur changer le réglage.
3. Appuyer sur **MODE** pour confirmer.
4. L'ordre de réglage est le suivant: format 12/24 heures, heure, minute, année, format du calendrier (jour-mois / mois-jour), mois, jour et langue.

Les options de langues disponibles sont l'anglais (**E**), l'allemand (**D**), le français (**F**), l'italien (**I**) et l'espagnol (**S**).

### Sélectionner le mode d'affichage:

Alterner **MODE** pour choisir entre l'horloge avec secondes / jours de la semaine/ calendrier / phase de la lune.

## PREVISIONS METEOROLOGIQUES

Ce produit prévoit plus de 12 heures de tendance météorologique dans un rayon de 19-31 miles (30-50 km).

	Ensoleillé
	Partiellement nuageux
	Nuageux
	Pluvieux
	Neigeux

## MESSAGE D'AVERTISSEMENT DE LA MÉTÉO

Les messages d'avertissement de la météo fournissent des indications sur les éventuelles circonstances qui peuvent survenir en fonction des calculs de la station météo. Les significations des avertissements sont illustrées ci-après:

AVERTISSEMENT	MESSAGE
	Risque de hautes températures
	Risque des vitesses de vent rapide
	Risque d'orage
	Risque de conditions brumeuses
	Risque de conditions de glace

## TEMPÉRATURE ET HUMIDITÉ

### Sélectionner l'appareil de température:

- Sélectionner °C ou °F pour les affichages de température à l'aide d'une épingle ou le bout d'un stylo.

### Sélectionner les affichages du capteur extérieur:

- Alternier ▲ pour sélectionner la affiche de votre capteur désiré.

### Rechercher automatiquement parmi les capteurs:

- Appui prolongé sur ▼ et sur MEM en même temps pour afficher les données du capteur pendant 3 secondes.
- Pour arrêter, appuyer sur ▲ .

### Pour afficher les enregistrements en cours, minimum et maximum de la journée à partir d'un capteur sélectionné:

- Alternier MEM.

### Effacer les enregistrements :

- Appui prolongé sur MEM.

## AVERTISSEMENT DE GEL

Si le capteur du canal 1 passe de 37°F à 28°F (3°C à -2°C), l'indicateur LED clignotera, et arrêtera de clignoter dès que la température est hors de cette plage.

- Appuyer sur ▲ et sur ▼ en même temps pour désactiver le message d'alerte de gel.

**REMARQUE** Puisque l'alerte de gel n'est applicable qu'au canal 1, pour éviter le clignotement du LED sélectionner le canal 2 ou 3 du capteur extérieur.









## TENDANCES METEOROLOGIQUES

Les icônes de tendance de température, d'humidité et de pression sont basées sur les affichages récents de capteur.

MONTÉE	CONSTANTE	CHUTE
		

## PHASE DE LA LUNE

En mode phase de la lune, appuyer sur ▲ ou sur ▼ pour effectuer des recherches au fil des années (2001 à 2099).

	Nouvelle lune		Pleine lune
	Ménisque croissante		Déclin gibbeux
	Premier quart		Troisième quart
	Gibbeuse ménisque		Déclin du croissant

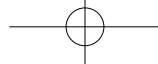

FR

**REMARQUE** Les icônes étoilées autour de la phase de la lune seront affichées à partir de 18 heures jusqu'à 6 heures le lendemain.

### BACKLIGHT (RÉTROÉCLAIRAGE)

Appuyer sur **LIGHT** (ECLAIRAGE) pour activer le rétro-éclairage pendant 5 secondes.

### RÉINITIALISER

Appuyer **RESET** (REINITIALISER) pour retourner aux réglages par défaut.

### CONNECTEZ-VOUS A UN TELEPHONE MOBILE

Vous pouvez régler la station météo mobile à distance et lire les informations via Bluetooth® 4.0 grâce à votre téléphone mobile avec une application téléchargée à partir d'Apple Store et Google Play Store. Pour retrouver rapidement l'application, veuillez saisir 'Weather@Home' comme mot clé dans le moteur de recherche.

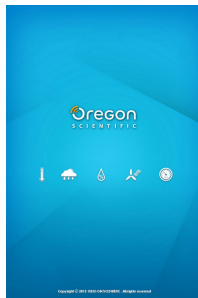

Assurez-vous que votre téléphone mobile est compatible avec l'iOS 8 ou Android 4,4 et Bluetooth® 4,0.

### APPARIEMENT DE VOTRE STATION METEOMOBILE

Veuillez d'abord appairier votre station météo mobile avec votre téléphone mobile.

☑ clignotera à l'écran de la station météo mobile pendant l'appariement et s'allumera après un appariement réussi.

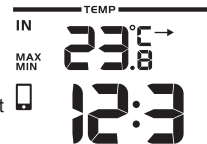

Appuyer sur ▲ pour activer un appariement avec l'appareil principal pendant 30 secondes.

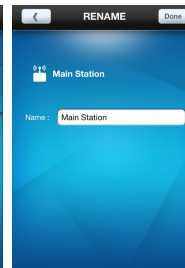
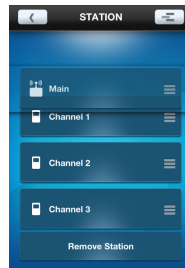

1. Ouvrez l'application, appuyez sur **Connecter**. Il cherchera automatiquement la station météo.
2. Une fois le couplage réussi, les numéros de station et de canal seront affichés.

- Appuyez sur chaque canal pour le renommer. (Jusqu'à 20 caractères y compris les espaces sont autorisés). Appuyez sur **Done** lorsque vous avez terminé. Appuyez sur **<** pour quitter.

### Supprimer la station météo :

Taper sur **Remove Station** (Supprimer Station) à l'écran **STATION**, la station météo sera désappareillé et ses données seront enlevées de l'application.

### Repositionner les capteurs à l'écran :

- A l'écran **STATION** taper sur **☰**.
- Appui prolongé sur **☰** à la droite d'un capteur. Faire glisser vers la position souhaitée.
- Taper sur **☑** pour confirmer.

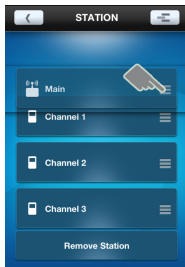

## RÉGLAGES

Vous pouvez régler votre station météo mobile à travers l'application, notamment les appareils de mesure.

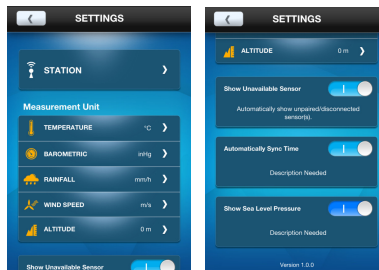

### Les réglages sont les suivants :

- Température
- Barométrie
- Pluviométrie (indisponible en BAR218HGX)
- Vitesse du vent (indisponible en BAR218HGX)
- Altitude
- Afficher le Capteur Indisponible
- Temps de synchronisation automatique
- Afficher la Pression du niveau de la mer

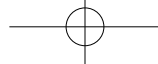



### Sélectionner l'appareil de mesure:

1. Taper sur  pour visualiser les options de l'appareil de mesure.
2. Taper sur votre appareil désiré.
3. Taper sur  pour retourner à l'écran précédent.

### Régler l'altitude:

L'altitude indique la distance du niveau de la mer à votre position.

1. Remplir l'altitude de votre appareil principal dans l'espace prévu.
2. Taper sur **Done** (Terminé).

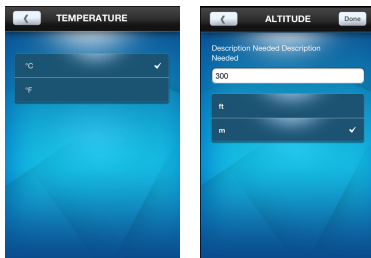

### VOIR LES AFFICHAGES EN COURS

Vous pouvez immédiatement voir en même temps tous les affichages météorologiques à partir des

capteurs différents grâce à cette application. Les affichages sont sur l'écran **HOME** (ACCUEIL) .

**REMARQUE** Si l'icône de la pile faible  s'affiche à l'écran, veuillez remplacer les piles de l'appareil correspondant.



### Afficher le Capteur Indisponible:

Si le capteur est hors de portée, les affichages s'interrompent et — (mode tirait) s'affichera à l'écran. Si vous ne souhaitez pas afficher le capteur indisponible:

- Sur l'écran **SETTINGS** (REGLAGES) , toucher et faire glisser le bouton à droite pour activer la fonction, ou faire glisser vers la gauche pour la désactiver.

### Synchroniser les temps automatiquement:

L'heure et la date sur votre station météo mobile peuvent être automatiquement synchronisées grâce à votre téléphone mobile.

- Sur l'écran **SETTINGS** (REGLAGES), toucher et faire glisser le bouton à droite pour activer la fonction, ou faire glisser vers la gauche pour le désactiver.

#### Afficher la pression du niveau de la mer:

Après avoir saisi l'altitude, vous pouvez voir la pression du niveau de la mer à l'écran **HOME** (ACCUEIL).



- Sur l'écran **SETTINGS** (REGLAGES), toucher et faire glisser le bouton à droite pour activer la fonction, ou faire glisser vers la gauche pour le désactiver.

**REMARQUE** Lorsque l'altitude est réglée à 0 mètre, le lecteur de la pression affiche la pression locale. Si l'altitude est réglée à l'emplacement en cours, le nouvel affichage de pression s'affichera comme pression du niveau de la mer.

#### VOIR L'HISTORIQUE DES AFFICHAGES

Vous pouvez voir l'historique à travers l'application. L'historique peut aussi être présentée sous forme de graphiques (dernières 24 heures ou derniers 7 jours).

#### Voir l'historique:

1. Taper sur la zone de votre capteur désiré à l'écran.
2. Taper sur  pour sélectionner les données désirées ou taper sur  pour trier les données par date.



#### PRÉCAUTIONS

- Utiliser uniquement des piles neuves du type et de la taille requise. Ne pas mélanger des piles anciennes et des piles neuves, ou différentes sortes de piles.
- Ne pas jeter les piles usagées avec les déchets communs. Jeter les piles dans les bacs de collecte destinés au recyclage des piles usagées.
- Enlever les piles si vous n'utilisez pas le produit durant une longue période. Les piles peuvent libérer des produits chimiques qui peuvent endommager les composants électroniques.
- Ne pas soumettre le produit à une force excessive, au choc, à la poussière, aux changements de température ou à l'humidité.



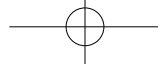

- Ne pas immerger le produit dans l'eau. Si vous reversez du liquide sur l'appareil, séchez-le immédiatement avec un tissu doux.
- Ne pas nettoyer l'appareil avec des matériaux corrosifs ou abrasifs.
- Ne pas trafiquer les composants internes. Cela invalidera votre garantie.
- Les images de ce manuel peuvent différer de l'aspect réel du produit.
- Lorsque vous désirez vous débarrasser de ce produit, assurez-vous qu'il soit collecté séparément pour un traitement adapté.
- Le contenu du présent manuel ne peut être reproduit sans la permission du fabriquant.

**REMARQUE** Les caractéristiques techniques de ce produit et le contenu de ce manuel peuvent être soumis à modifications sans préavis.

**REMARQUE** Caractéristiques et accessoires ne seront pas valables pour tous les pays. Pour plus d'information, contacter le détaillant le plus proche. Pour télécharger une version électronique de ce mode d'emploi, veuillez visiter <http://global.oregonscientific.com/customerSupport.php>.

## SPECIFICATIONS

TYPE	DESCRIPTION
<b>APPAREIL PRINCIPAL</b>	
(L x l X H)	7,32 x3,7 x 2,13 po (186 x 94 x 54 mm)
Poids	223 g (7,87onces) sans pile
Plage de température	-5°C à 50°C (23°F à 122°F)
Fréquence du signal	433 MHz
Plage de l'humidité	25% - 95%
Source d'alimentation	Piles de 3 x UM-3 (AA) 1,5V
Plage de température pour recevoir un avertissement de gel	3°C à -2°C
<b>SONDE SANS FIL (THGR511)</b>	
L X l x H	96 x 50 x 22 mm (3,78 x 1,97 x 0,87 pouces)
Poids	49 g (1,7 onces)
Distance de transmission	30 m (98 pieds) sans obstruction
Plage de mesure de température	-20°C à 60°C (-4°F° à 140 °F)
Alimentation	2 Piles UM 4 (AAA) 1,5 V

## À PROPOS D'OREGON SCIENTIFIC

Pour plus d'informations sur les produits Oregon Scientific France, rendez-vous sur notre site

[www.oregonscientific.fr](http://www.oregonscientific.fr).

Besoin de plus d'informations? Contactez notre service client expert à [info@oregonscientific.fr](mailto:info@oregonscientific.fr).

Oregon Scientific Global Distribution Limited se réserve le droit d'interpréter tout contenu, termes et provisions du présent manuel de l'utilisateur et de les amender à sa seule discrétion, n'importe quand et sans avis préalable. Dans la mesure où des incohérences sont constatées entre la version anglaise et les versions traduites en langues étrangères, la version anglaise prévaudra.



## EU – DÉCLARATION DE CONFORMITÉ

Le fabricant, Oregon Scientific Global Distribution Limited, déclare que le type d'équipement radio Weather@Home Station météo mobile compatible à Bluetooth (Modèle: BAR218HGX) est conforme à la directive 2014/53/UE. Le texte intégral de la déclaration de conformité de l'UE est disponible à l'adresse Internet suivante:

<http://global.oregonscientific.com/customerSupport.php>



### PAYS CONCERNÉS RED

Tous les pays Européens, la Suisse   
et la Norvège 

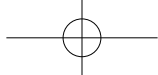

## INFORMATIONS AUX USAGERS



**Aux termes des Directives européennes 2011/65/EU et 2012/19/EU, relatives à la réduction de l'utilisation de substances dangereuses dans les appareils électriques et électroniques et à l'élimination des déchets.**

Le symbole représentant une poubelle barrée reporté sur l'appareil indique que le produit doit être collecté séparément des autres déchets à la fin de sa propre vie.

L'utilisateur devra donc remettre l'appareil, lorsqu'il ne l'utilisera plus, à des centres adaptés de collecte sélective pour les déchets électroniques et électrotechniques, ou bien il devra le rapporter au revendeur au moment de l'achat d'un nouvel appareil de type équivalent, en raison d'un contre un.

La collecte sélective adéquate pour la transmission successive de l'appareil qui n'est plus utilisé au recyclage, au traitement ou à l'élimination compatible au niveau environnemental, contribue à éviter les effets négatifs possibles sur l'environnement et sur la santé et favorise le recyclage des matériaux dont l'appareil est composé.

L'élimination illégale du produit par l'utilisateur est passible de l'application de sanctions selon les lois en vigueur.



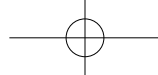

DE

**Weather@Home**  
**Bluetooth-Wetterstation**  
**Modell: BAR218HGX**  
 Bedienungsanleitung

**INHALT**

**Einleitung**-----2

**Übersicht** -----2

    Frontansicht -----2

    Rückansicht -----3

    Externer sensor -----3

**Vorbereitung zum einsatz**-----4

    Einlegen der batterien -----4

**Externer sensor** -----4

    Daten-übertragung -----4

**Uhr**-----5

    Manuelle einstellung der uhr -----5

**Wettervorhersage**-----5

**Wettervorhersage / warnungen** -----5

**Temperatur und luftfeuchtigkeit** -----6

    Eis-warnung -----6

    Wetter - trendvorhersage -----6

**Mondphasen**-----7

**Anzeigebeleuchtung**-----7

**Rücksetzung** -----7

**Verbindung mit einem mobilen gerät** -----7

    Anmeldung der wetterstation -----7

    Einstellungen -----8

    Aktuelle messwerte anzeigen -----9

    Messdaten-verlauf anzeigen -----10

**Vorsichtsmassnahmen** -----11

**Technische daten** -----12

**Über Oregon Scientific**-----12

**EU-Konformitätserklärung**-----13

**Informationen Für Die Denutzer** -----13

## EINLEITUNG

Wir danken Ihnen für den Kauf unserer Oregon Scientific™ Weather@Home Bluetooth-Wetterstation. Darüber hinaus ist es auch eine Anzeigevorrichtung für Veränderungen der Innen- und Außentemperatur.

**HINWEIS** Halten Sie bitte diese Anleitung bereit, wenn Sie Ihr neues Produkt in Betrieb nehmen. Sie enthält praktische Schritt-für-Schritt-Anweisungen sowie technische Daten und wichtige Warnhinweise für den Umgang mit diesem Gerät.

## ÜBERSICHT

### FRONTANSICHT

1. Signal-Indikator für externen Sensorempfang und Außenanzeige-Kanal ausgewählt.
2. : Batterie für externen Sensor ist schwach
3. : Wettervorhersage für die kommenden 12 Stunden und Luftdrucktendenz
4. : Wetterwarnungen
5. Innentemperatur-Anzeige (aktuell/**MAX/MIN**) (aktuell/**MAX/MIN**)
6. : BLE Indikator für BLE-Verbindung
7. : Batterie für Basisstation ist schwach
8. LED-Indikator für Eiswarnung
9. **MODE** (MODUS): Einstellungen ändern / Anzeige

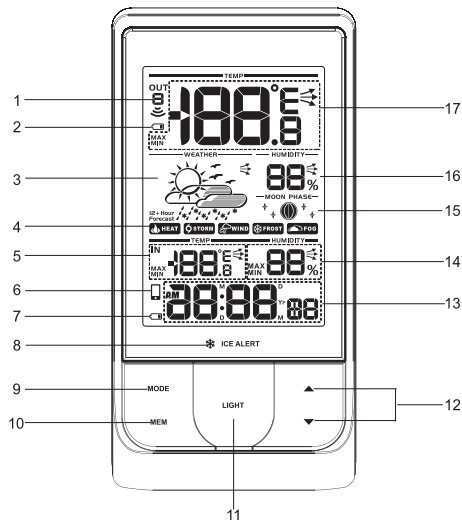

10. **MEM** (SPEICHER): Aktuelle Anzeige, Maximum- und Minimum-Temperatur / Luftfeuchtigkeit
11. **LIGHT** (LICHT): Anzeigebeleuchtung aktivieren
12. ▲ / ▼: Aufwärts/Abwärts für Einstellungen; Umschaltung mit ▲ -Taste für Auswahl der Außenkanäle (1-5); aktivieren / deaktivieren des Anmelden-Modus.



DE

13. **AM/PM:** Vormittag/Nachmittag  
**MD/DM/Yr:** Kalender / Uhr mit Wochentag (Stunde : Minute mit Sekundenanzeige)
14. Innen-Luftfeuchtigkeit-Anzeige aktuell/**MAX/MIN** (aktuell/**MAX/MIN**) (mit Luftfeuchtigkeitstendenz)
15. Mondphasenanzeige
16. Außenluftfeuchtigkeit-Anzeige (aktuell /**MAX/MIN**) (aktuell /**MAX/MIN**) mit Luftfeuchtigkeit-Tendenz
17. Außentemperatur-Anzeige (aktuell/**MAX/MIN**) (aktuell /**MAX/MIN**) mit Temperaturtendenz

#### RÜCKANSICHT

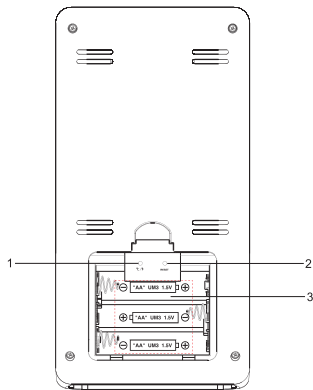

1. °C / °F: Temperaturanzegeeinheit auswählen
2. **RESET** (RÜCKSETZUNG): Rücksetzung des Gerätes auf die Werkseinstellungen
3. Batteriefach

#### EXTERNER SENSOR

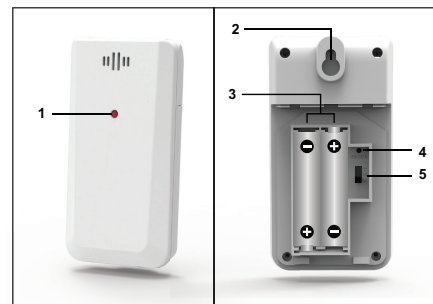

1. LED-Statusindikator
2. Öffnung für Wandmontage
3. Batteriefach
4. **RESET**-Öffnung
5. **CHANNEL**-Schalter

## VORBEREITUNG ZUM EINSATZ

### EINLEGEN DER BATTERIEN

1. Öffnen Sie das Batteriefach.
2. Legen Sie die Batterien ein, und achten Sie auf die korrekte Ausrichtung der Polarisierungsangaben (+/-).
3. Betätigen Sie die **RESET** (RESET-Taste) nach jedem Batteriewechsel.

Anzeige	BEDEUTUNG
Uhr / Alarmzone	Basisstation Batterien schwach.
Außentemperaturzone	Sensor Batterien schwach

### EXTERNER SENSOR

Die Basisstation kann Daten von 5 externen Sensoren empfangen.

#### Installation des Sensors:

1. Öffnen Sie das Batteriefach.
2. Wählen Sie einen Kanal und betätigen Sie **RESET** (RÜCKSETZEN).
3. Schließen Sie das Batteriefach wieder.
4. Platzieren Sie den Sensor nicht weiter als 30m (98 ft) von der Basisstation mittels des integrierten Ständers oder bringen Sie das Gerät an der Wand an.

**TIPP** Idealerweise stellen Sie den Sensor an einem Ort im Freien nicht höher als 1,5m über dem Boden auf, und wo das Gerät nicht der direkten Sonneneinstrahlung oder Feuchtigkeit ausgesetzt ist, um zuverlässige Messergebnisse zu erzielen.

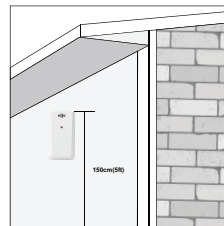

**HINWEIS** Verwenden Sie stets Alkaline-Batterien oder Lithium-Batterie für Temperaturen unter dem Gefrierpunkt um eine längere Lebensdauer der Batterie zu gewährleisten.

### DATEN-ÜBERTRAGUNG

#### Sensorsuche:

Drücken und halten Sie **▲** und die **MODE**-Taste (MODUS) gleichzeitig gedrückt.

**Das Empfangssymbol für das Sensorsignal im Anzeigefeld für den externen Sensor zeigt den Status an:**



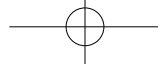

ICON	DESCRIPTION
	Main unit is searching for sensor(s).
	A channel has been found.
	The sensor cannot be found.

**TIPP** Die Übertragungreichweite hängt von verschiedenen Faktoren ab. Es kann sein, dass Sie mehrere Orte für die externen Sensoren testen müssen, bevor Sie eine optimale Signalübertragung erhalten.

## UHR

### MANUELLE EINSTELLUNG DER UHR

- Halten Sie die **MODE**-Taste (MODUS) gedrückt.
- Betätigen Sie die Tasten **▲** oder **▼**, um die Einstellungen zu ändern.
- Betätigen Sie die **MODE**-Taste (MODUS), um die Einstellungen zu bestätigen.
- Die Einstellsequenz schreitet wie folgt fort: 12/24 Stundenformat, Stunde, Minute, Jahr, Kalenderformat (Datum-Monat / Monat-Datum), Monat, Wochentag und Anzeigeprache.

Als Sprachoptionen stehen Englisch (**E**), Deutsch (**D**), Französisch (**F**), Italienisch (**I**), und Spanisch (**S**) zur Auswahl.

### Auswahl des Anzeigemodus:

Schalten Sie mittels der **MODE**-Taste (MODUS) zwischen der Anzeige für Uhrzeit mit Sekundenanzeige / Wochentag/ Kalender / Mondphase um.

## WETTERVORHERSAGE

Diese Gerät erstellt eine Wettervorhersage für die kommenden 12 Stunden in einem Umkreis von 30 – 50 km (19 – 31 Meilen).



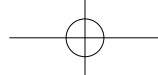

	Sonnig
	Teilweise bewölkt
	Bewölkt
	Regen
	Schnee

## WETTERVOHERSAGE / WARNUNGEN

Die Wettervorhersage-Warnungen geben einen Hinweis darauf, wie sich das Wetter durch den Einfluss verschiedener Faktoren basierend auf den Berechnungen der Basisstation ändern könnten. Die Bedeutung der jeweiligen Warnhinweise wird nachfolgend erklärt:



DE

WARNHINWEIS	BEDEUTUNG
 HEAT	Möglicherweise hohe Temperaturen
 WIND	Möglicherweise starker Wind
 STORM	Sturmrisiko
 FOG	Möglicherweise Nebel
 FROST	Möglicherweise Eisgefahr

## TEMPERATUR UND LUFTFEUCHTIGKEIT

### Auswahl der Temperaturanzeige-Einheit:

- Stellen Sie die Anzeige auf °C oder °F für die Anzeige der gemessenen Temperaturen mittels einer Nadel oder einer Kugelschreibespitze ein.

### Auswahl der Messwert-Anzeige eines externen Sensors:

- Umschaltung mittels ▲ für die Auswahl des gewünschten Sensorkanals.

### Automatische Weiterschaltung der Messwert-Anzeige zwischen den Sensoren:

- Drücken und halten Sie ▼ und MEM (SPEICHER) gleichzeitig gedrückt, um die Messdaten für jeden Sensor ca. 3 Sekunden lang anzuzeigen.
- Betätigen Sie ▲, um den Messwertedurchlauf zu beenden.

Um die aktuell gespeicherten Maximal- und Minimalwerte des Tages für einen ausgewählten Sensor anzuzeigen, gehen Sie wie folgt vor:

- Weiterschalten mit MEM-Taste (SPEICHER).

### Löschen der Speichereinträge:

- Drücken und halten Sie die MEM-Taste (SPEICHER).

## EIS-WARNUNG

Wenn der Messwert für den Sensor auf Kanal 1 von 37°F to 28°F (3°C to -2°C) fällt, dann blinkt der LED-Indikator; 3° C bis -2°C (37°F bis 28°F) der Indikator blinkt nicht mehr, sobald der Temperaturmesswert außerhalb dieses Bereichs liegt.

- Betätigen Sie gleichzeitig die Tasten ▲ und ▼, um die Eiswarnung-Funktion zu deaktivieren.

**HINWEIS** Da die Eiswarn -Funktion nur für Kanal 1 zur Verfügung steht, sollten Sie für externe Sensoren die Kanäle 2 und 3 wählen, um zu verhindern dass die LED-Anzeige permanent blinkt.

## WETTER - TRENDVORHERSAGE

Die Trend-Symbole für Temperatur, Luftfeuchtigkeit und Luftdruck beruhen auf den jüngsten Messungen der Sensoren.

STEIGEND	KONSTANT	FALLEND
		

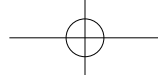

## MONDPHASEN

Betätigen Sie die Tasten ▲ oder ▼ im Mondphasenmodus, um die Mondphasen für ein gewünschtes Jahr (2001 to 2099) anzuzeigen.

	Neumond		Vollmond
	Sichelmond zunehmend		Sichelmond abnehmend
	Erstes Viertel		Drittes Viertel
	Sichelmond zunehmend		Sichelmond abnehmend

**HINWEIS** Stern-Indikatoren werden im Umkreis der Anzeige der Mondphase zwischen 6 Uhr abends und 6 Uhr des morgens des nächsten Tages angezeigt.

## ANZEIGEBELEUCHTUNG

Betätigen Sie die **LIGHT**-Taste (LICHT), um die Anzeigebeleuchtung 5 Sekunden lang anzuzeigen.

## RÜCKSETZUNG

Betätigen Sie die **RESET**-Taste (RÜCKSETZUNG), um eine Rücksetzung auf die Werkseinstellungen vorzunehmen.

## VERBINDUNG MIT EINEM MOBILEN GERÄT

Sie können über eine Bluetooth® 4.0 Verbindung die Einstellungen für die Wetterstation über ein mobiles Gerät vornehmen, und die Wetterinformationen abrufen, vorausgesetzt Sie laden das entsprechende Anwendungsprogramm vom Apple Store und vom Google Play Store herunter. Suchen Sie nach den Stichworten **'Weather@Home'** in der Suchmaschine, um die Anwendung schnell und problemlos zu finden.



Stellen Sie sicher dass Ihr mobiles Gerät mit dem iOS 8 oder Android 4,4 mit Bluetooth® 4,0 kompatibel ist.

## ANMELDUNG DER WETTERSTATION

Zuerst müssen Sie Ihre Wetterstation bei ihrem mobilen Gerät anmelden.

blinkt in der Station während die Anmeldung ausgeführt wird, und erscheint permanent, wenn die Anmeldung erfolgreich war.

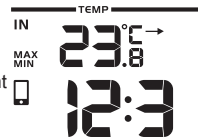

Betätigen Sie ▲ , um die Anmeldung für die Basisstation für ca. 30 Sekunden auszuführen.



1. Öffnen Sie die App, tippen Sie auf **Verbinden**. Sie sucht automatisch nach der Wetterstation.
2. Sobald die Kopplung erfolgreich war, werden die Stations- und Kanalnummern angezeigt.
3. Jeden Kanal wählen, um ihn neu zu benennen (erlaubt sind bis zu 20 Zeichen, einschließlich Leerzeichen). Wenn erledigt, auf **Done** /tippen. Zur Beendigung auf <img alt="back arrow icon" data-bbox="265 635 300 660"/> drücken.

#### Wetterstation entfernen:

Tippen Sie auf **Remove Station** (Basisstation abtrennen) im **STATION-Menü** (BASISSTATION-Menü), die Wetterstation wird nicht gekoppelt und die Daten werden aus der App entfernt.

#### Verschieben der Sensor-Schaltflächen im Bildschirm:

1. Tippen Sie im **STATION-Menü** (BASISSTATION) auf <img alt="station menu icon" data-bbox="595 265 630 290"/>.
2. Halten Sie <img alt="station menu icon" data-bbox="645 295 670 320"/> auf der rechten Seite der Sensorschaltfläche gedrückt. Ziehen Sie die Schaltfläche nun in die gewünschte Position.
3. Tippen Sie auf <img alt="station menu icon" data-bbox="665 460 690 485"/>, um zu bestätigen.



#### EINSTELLUNGEN

Sie können die Einstellungen für Ihre Wetterstation, z.B. die Einheitenanzeige, auch über die App vornehmen.

#### Die folgenden Einstellungen können ausgeführt werden:

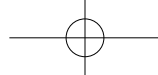

- Temperatur
- Barometer
- Niederschlagsmenge (nicht verfügbar für BAR218HGX)

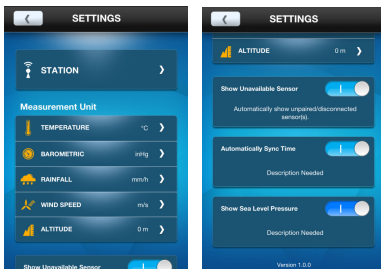

- Windgeschwindigkeit (nicht verfügbar für BAR218HGX)
- Höhe
- Anzeige nicht verfügbarer Sensoren
- Automatische Zeitsynchronisation
- Anzeige für Luftdruck über Meeresspiegel



### Auswahl der Einheitenanzeige:

1. Tippen Sie auf , um die Auswahloptionen für die Einheitenanzeige aufzurufen.
2. Tippen Sie auf die gewünschte Maßeinheit.
3. Tippen Sie auf , um zum vorherigen Bildschirm zurück zu schalten.

### Höhe über Meeresspiegel programmieren:

Die Höhenanzeige gibt die Höhe über dem Meeresspiegel für ihren aktuellen Aufenthaltsort an.

1. Geben Sie die Höhe über dem Meeresspiegel für Ihren Aufenthaltsort im Leerfeld ein.
2. Tippen Sie auf **Done** (Abschließen).

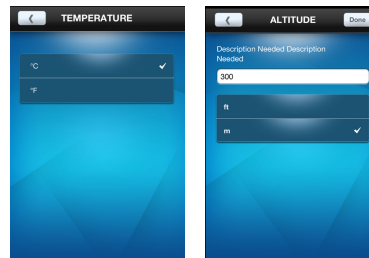

### AKTUELLE MESSWERTE ANZEIGEN

Sie können sich alle Wetterdaten von den verschiedenen Sensoren über die App anzeigen lassen. Die Anzeige der Werte erfolgt im **HOME**-Bildschirm (HAUPT-Bildschirm) der App.

**HINWEIS** Bitte wechseln Sie die Batterien des entsprechenden Gerätes aus, sobald das -Symbol für schwache Batterien im Bildschirm erscheint.

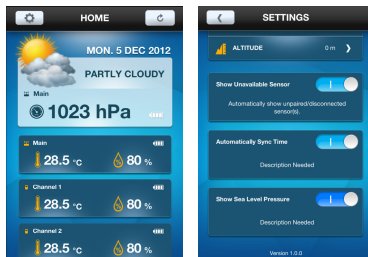

#### Nicht verfügbare Sensoren anzeigen:

Wenn ein Sensor Werte misst, die außerhalb des Messbereichs liegen, dann werden keine Messwerte angezeigt, und es erscheint — (Trennstich-Modus) im Hauptbildschirm. Wenn Sie die Anzeige für nicht verfügbare Sensoren unterdrücken möchten, gehen Sie wie folgt vor:

- Im **SETTINGS**-Menü (EINSTELLUNGEN), berühren Sie den Schieber und schieben Sie diesen nach Rechts, um die Funktion einzuschalten, oder nach Links, um die Funktion auszuschalten.

#### Automatische Synchronisation der Zeit:

Zeit und Datum für die Wetterstation können automatisch mit der Zeit Ihres mobilen Gerätes synchronisiert werden.

- Im **SETTINGS**-Menü (EINSTELLUNGEN) berühren Sie den Schieber und schieben Sie diesen nach rechts, um die Funktion einzuschalten, oder nach links, um die Funktion auszuschalten.

#### Anzeige des Luftdrucks über Meereshöhe:

Nachdem Sie die Höhe über dem Meeresspiegel für Ihren Ort eingegeben haben, können Sie den Luftdruck über Meereshöhe im **HOME-Bildschirm** (HAUPT-Bildschirm) anzeigen.

- Berühren Sie den Schieber und schieben Sie diesen nach rechts im **SETTINGS**-Bildschirm (EINSTELLUNGEN) um die Anzeige einzuschalten, und nach links, um die Funktion wieder auszuschalten.





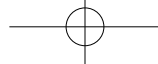

**HINWEIS** Wenn eine Höhe von „0“ Metern eingestellt ist, dann erfolgt die Anzeige für den gemessenen Luftdruck für Ihren aktuellen Aufenthaltsort. Wenn Sie die Höhe für ihren Aufenthaltsort eingeben, dann erfolgt die neue Luftdruckanzeige für den Luftdruck über Meereshöhe.

#### MESSDATEN-VERLAUF ANZEIGEN

Sie können sich den Messdaten-Verlauf über die App anzeigen lassen. Die Messdatenverläufe können auch als Graphen (für die letzten 24 Stunden oder für 7 Tage angezeigt werden).



### Anzeige der Messdatenverläufe:

1. Tippen Sie auf die Schaltfläche für den gewünschten Sensor im Bildschirm.
2. Tippen Sie auf , , , um die gewünschten Daten auszuwählen, oder tippen Sie auf , um die Messdaten nach dem Datum zu sortieren.



### VORSICHTSMASSNAHMEN

- Verwenden Sie nur neue Batterien gemäß angegebener Größe und Typen. Vermischen Sie nicht alte und neue Batterien, vermeiden Sie unterschiedliche Batterietypen.
- Batterien gehören nicht in den Hausmüll. Gebrauchte Batterien müssen zur fachgerechten Entsorgung abgegeben werden.
- Wenn Sie die Gerät für eine längere Zeit nicht benutzen, müssen die Batterien aus dem Batteriefach entfernt werden. Chemische Flüssigkeiten, die aus den Batterien austreten, führen zu Schäden an den elektronischen Teilen.
- Setzen Sie das Gerät keiner extremen Gewalteinwirkung und keinen Stößen aus, und halten Sie es von übermäßigem Staub, Hitze oder Feuchtigkeit fern.
- Tauchen Sie das Gerät niemals in Wasser. Falls Sie eine Flüssigkeit über das Gerät verschütten, trocknen Sie es sofort mit einem weichen, faserfreien Tuch.
- Reinigen Sie das Gerät keinesfalls mit scheuernden oder ätzenden Mitteln.
- Machen Sie sich nicht an den internen Komponenten des Geräts zu schaffen, da dies zu einem Verlust der Garantie führen kann.
- Die in dieser Anleitung dargestellten Abbildungen können sich vom Original unterscheiden.
- Entsorgen Sie das Produkt nicht im allgemeinen Hausmüll, sondern ausschließlich in den dafür vorgesehenen, kommunalen Sammelstellen, die Sie bei Ihrer Gemeinde erfragen können.
- Der Inhalt dieser Anleitung darf ohne Genehmigung des Herstellers nicht vervielfältigt werden.

**HINWEIS** Die technischen Daten für dieses Produkt und der Inhalt der Bedienungsanleitung können ohne Benachrichtigung geändert werden.

**HINWEIS** Eigenschaften und Zubehör nicht in allen Ländern verfügbar. Weitere Informationen erhalten Sie von Ihrem Fachhändler vor Ort. Bitte besuchen Sie unsere Internetseite <http://global.oregonscientific.com/customerSupport.php>, um eine elektronische Version dieser Bedienungsanleitung herunter zu laden.

**TECHNISCHE DATEN**

TYP	BESCHREIBUNG
<b>BASISSTATION</b>	
L x B x H	7,32 x 3,7 x 2,13 Zoll 186 x 94 x 54 mm
Gewicht	223 g ohne Batterie
Temperatur -Messbereich	-5°C to 50°C (23°F to 122°F)
Signal-Frequenz	433 MHz
Luftfeuchtigkeit- Messbereich	25% - 95%
Stromversorgung	3 x UM-3 (AA) 1,5V Batterien
Temperaturbereich bei Frostwarnung	3° bis -2° Celsius
<b>FUNKSENDEEINHEIT (THGR511)</b>	
L x B x H	96 x 50 x 22 mm
Gewicht	49 g
Übertragungreichweite	30 m (ohne Hindernisse)
Temperaturbereich	-20 °C bis 60 °C (-4 °F bis 140 °F)
Stromversorgung	2 Batterien UM-4 (AAA) 1,5 V

**ÜBER OREGON SCIENTIFIC**

Besuchen Sie unsere Website [www.oregonscientific.de](http://www.oregonscientific.de), um mehr über die Produkte von Oregon Scientific zu erfahren.

Für etwaige Anfragen kontaktieren Sie bitte unseren Kundendienst unter [info@oregonscientific.de](mailto:info@oregonscientific.de).

Oregon Scientific Global Distribution Limited behält sich das Recht vor, die Inhalte, Bedingungen und Bestimmungen in dieser Bedienungsanleitung zu interpretieren und auszulegen, und diese jederzeit nach eigenem Ermessen ohne vorherige Ankündigung abzuändern. Soweit es irgendwelche Unterschiede zwischen der englischen Version und den Versionen in anderen Sprachen gibt, ist die englische Version maßgebend.



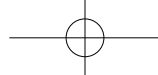



## EU-KONFORMITÄTSERKLÄRUNG

Hiermit erklärt der Hersteller, Oregon Scientific Global Distribution Limited, dass der Funkausrüstungs-Typ Weather@Home Bluetooth-Wetterstation (Modell: BAR218HGX) In Übereinstimmung mit 2014/53/EU ist. Den vollständigen Wortlaut der EU-Konformitätserklärung finden Sie unter folgender Internetadresse:

<http://global.oregonscientific.com/customerSupport.php>



### KONFORM IN FOLGENDEN LÄNDERN

Alle Länder der EU, Schweiz   
und Norwegen 

## INFORMATIONEN FÜR DIE BENUTZER



Gemäß den Europäischen Richtlinien 2011/65/EU und 2012/19/EU über die Reduzierung der Verwendung gefährlicher Stoffe in elektrischen und elektronischen Geräten, sowie die Abfallentsorgung.

Das Symbol der durchgestrichenen Mülltonne auf dem Gerät besagt, dass es am Ende seiner Verwendungszeit getrennt von anderen Abfällen entsorgt werden muss.

Der Benutzer muss daher das Gerät nach Beendigung seiner Verwendungsdauer zu geeigneten Sammelstellen für die getrennte Abfallentsorgung von elektrischen und elektronischen Geräten bringen oder es dem Endverkäufer beim Kauf eines neuen Geräts von ähnlicher Art im Verhältnis eins zu eins übergeben.

Die angemessene Abfalltrennung und die darauf folgende Verbringung des aufgelassenen Geräts in den Recyclingkreislauf zur umweltverträglichen Verwertung und Entsorgung tragen dazu bei, mögliche negative Auswirkungen auf die Umwelt und die Gesundheit zu vermeiden und sie begünstigen das Recycling von Materialien, aus denen das Gerät besteht.

Die rechtswidrige Entsorgung des Produktes veranläßt die Verwendung der geltenden Verwaltungsanktionen.



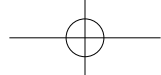

ES

**Estación Meteorológica  
Weather@Home con Bluetooth  
Modelo: BAR218HGX**

Manual del usuario

**CONTENIDO**

**Introducción** .....2

**Síntesis** .....2

    Vista frontal .....2

    Vista trasera .....3

    Sensor remoto (THGR511) .....3

**Indicaciones** .....4

    Inserte las pilas .....4

**Sensor remoto** .....4

    Transmisión de datos al sensor .....4

**Reloj** .....5

    Ajuste manualmente el reloj .....5

**Pronóstico del tiempo** .....5

**Mensaje de advertencia climática** .....5

**Temperatura y humedad** .....6

    Advertencia de heladas .....6

**Tendencias del tiempo** .....6

**Fase lunar** .....6

**Iluminación de fondo** .....7

**Reinicio** .....7

**Conectar con su dispositivo móvil** .....7

    Acoplamiento de la estación meteorológica .....7

    Configuración .....8

    Visualización de las lecturas corrientes .....9

    Ver historial de lecturas .....10

**Precauciones ...** .....11

**Especificaciones** .....12

**Sobre Oregon Scientific** .....12

**EU - Declaración de conformidad** .....13

**Información de Usuarios** .....13

## INTRODUCCIÓN

Gracias por elegir nuestra Oregon Scientific™ Estación Meteorológica Weather@Home con Bluetooth. Además, también se lleva a cabo la pantalla cambiable entre las temperaturas interior y exterior.

**NOTA** Tenga este manual a mano cuando use el nuevo producto. Contiene prácticas instrucciones explicadas paso a paso, así como especificaciones técnicas y advertencias que debe conocer.

## SINOPSIS

### VISTA FRONTAL

1. Indicador de recepción del sensor remoto y del canal de intemperie seleccionado
2. : batería baja del sensor remoto de intemperie
3. **12+ Hour Forecast**: Pronóstico del tiempo para las próximas 12 horas y tendencia de la presión
4. : mensaje de advertencia climática
5. Lectura de la temperatura interior (corriente/**MAX/ MIN**) con la tendencia de la temperatura
6. Indicador de conexión BLE
7. : batería baja de la unidad principal
8. indicador LED de alerta de heladas
9. **MODE**(modo): cambiar la configuración/pantalla

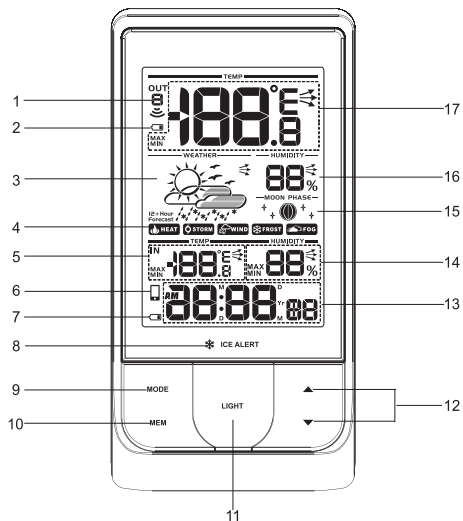

10. **MEM**: Ver la corriente, temperatura máxima y mínima / humedad
11. **LIGHT**(luz): activar la iluminación de fondo
12. / : aumentar / disminuir el valor de la configuración; pulse con alternancias el botón para seleccionar los canales de intemperie (1-5); activar / desactivar el modo de acoplamiento.

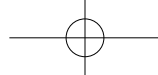

13. **AM / PM**: mañana/tarde

**MD** (mes-día)/**DM** (día-mes)/**Año**: calendario / reloj con día de la semana (muestra hora, minutos y segundos)

14. Lectura de humedad interior (corriente/**MAX/MIN**) con la tendencia de la humedad

15. Muestra la fase lunar

16. Humedad exterior (corriente /**MAX/MIN**) con la tendencia de la humedad

17. Lectura de la temperatura exterior (corriente /**MAX/MIN**) con la tendencia de la temperatura

#### VISTA TRASERA

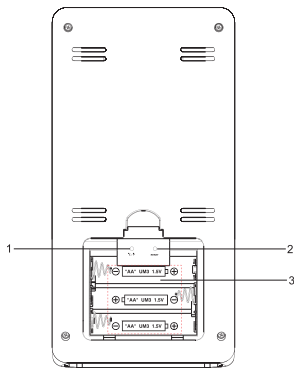

1. °C / °F: seleccionar la unidad de temperatura
2. **RESET**(restaurar): Restaurar la configuración predeterminada
3. Compartimiento de la pilas

#### SENSOR REMOTO (THGR511)

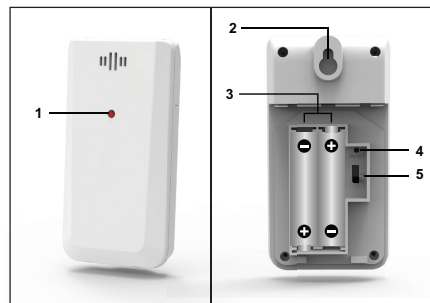

1. Indicador LED de estado
2. Orificio para montaje en pared
3. Compartimiento para las pilas
4. Orificio de **RESET**
5. Cambio de **CANAL**

**INDICACIONES****INSERTE LAS PILAS**

1. Retire el compartimiento de la batería.
2. Inserte las pilas haciendo coincidir la polaridad (+/-).
3. Pulsar **RESET**(restaurar) después de cada cambio de pilas.

 <b>UBICACIÓN</b>	<b>MEANING</b>
Área de reloj/alarma	Batería baja en la unidad principal
Área de la temperatura exterior	Batería baja de sensor

**SENSOR REMOTO**

La unidad principal puede recoger datos de hasta 5 sensores.

**Para configurar el sensor:**

1. Abra el compartimiento de las pilas.
2. Seleccione un canal y pulse **RESET**(restaurar).
3. Cierre la puerta de la batería.
4. Coloque el sensor en un radio de 98 pies (30 m) de la unidad principal usando el soporte de mesa o de pared.

**CONSEJO** La ubicación ideal para el sensor sería en cualquier lugar en el exterior de la casa a una altura no mayor que 5 pies (1,5 m) y que ofrezca protección de la luz solar directa o de condiciones de humedad para obtener una lectura precisa.

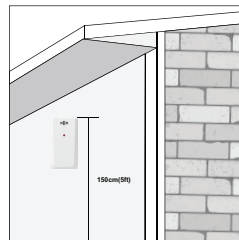

**NOTA** Use pilas alcalinas para larga duración y pilas de litio en temperaturas bajo cero.

**TRANSMISIÓN DE DATOS AL SENSOR****Para buscar un sensor:**

Pulse y mantenga pulsado **▲** y **MODE**(modo) al mismo tiempo.

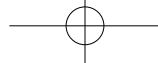

**El icono de recepción del sensor del área del sensor remoto muestra el estado:**

ICONO	DESCRIPCIÓN
	La unidad principal está buscando a los sensores.
	Se ha encontrado un canal.
	No se puede encontrar el sensor.

**CONSEJO** El alcance de la transmisión puede variar dependiendo de varios factores. Puede que tenga que probar varias ubicaciones para obtener los mejores resultados.

## RELOJ

### AJUSTE MANUALMENTE EL RELOJ

1. Pulse y mantenga **MODE**(modo).
2. Pulse **▲** o **▼** para cambiar la configuración.
3. Pulse **MODE**(modo) para confirmar.
4. La secuencia de configuración es: formato de 12/24 horas, hora, minuto, año, formato de calendario (días / mes-día), mes, día y el lenguaje.

Las opciones de idioma son Inglés (**E**), Alemán (**D**), Francés (**F**), Italiano (**I**) y Español (**S**).

**Para seleccionar el modo de pantalla:**

Pulse con alternancias **MODE**(modo) para elegir entre reloj con segundos / día de la semana / calendario / fase lunar.





## PRONÓSTICO DEL TIEMPO

Este producto predice las siguientes 12 horas de las condiciones climáticas en un radio de 19-31 millas (30-50 km).

	Soleado
	Parcialmente nublado
	Nublado
	Lluvioso
	Probabilidad de nevada

## MENSAJE DE ADVERTENCIA CLIMÁTICA

Los mensajes de advertencia climática proporcionan indicios de circunstancias posibles que puedan surgir sobre la base de los cálculos de la estación meteorológica. Los significados de las advertencias se ilustran a continuación:

ADVERTENCIA	MENSAJE
 HEAT	Riesgo de altas temperaturas
 WIND	Riesgo de vientos fuertes
 STORM	El riesgo de tormenta
 FOG	Riesgo de niebla
 FROST	Riesgo de heladas

## TEMPERATURA Y HUMEDAD

### Para seleccionar la unidad de temperatura:

- Seleccionar °C o °F para las lecturas de temperatura mediante un alfiler o la parte superior de un lápiz.

### Para seleccionar las lecturas de un sensor exterior:

- Pulse con alternancias ▲ para seleccionar la lectura del sensor deseado.

### Para lecturas automáticas de los sensores:

- Pulse y mantenga pulsado ▼ y MEM al mismo tiempo para mostrar los datos de cada sensor durante 3 segundos.
- Para finalizar, pulse ▲.

### Para mostrar los registros actuales, mínimos y máximos del día de un sensor seleccionado:

- Pulse con alternancias MEM

### Para borrar los registros:

- Pulse y mantenga MEM.

## ADVERTENCIA DE HELADAS

Si el sensor del canal 1 cae de 37°F a 28°F (3°C a -2°C), el indicador LED parpadea, y dejará de parpadear cuando la temperatura esté fuera de este rango.

- Pulse ▲ y ▼ al mismo tiempo para desactivar la alerta de advertencia de heladas.

**NOTA** Como alerta de heladas sólo se aplica al canal 1, para evitar el parpadeo del LED, seleccione el canal 2 o 3 en el sensor exterior.

## TENDENCIAS DEL TIEMPO

Los iconos de tendencia de temperatura, humedad y presión se basan en las lecturas recientes de los sensores.

SUBA	ESTABLE	BAJA
		

## FASE LUNAR

En el modo de fase lunar, pulse ▲ o ▼ para buscar entre los años (2001-2099).



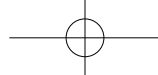

	Luna nueva		Plenilunio
	Cuarto creciente		Cuarto menguante
	Primer cuarto		Tercer cuarto
	Media luna creciente		Media luna menguante

**NOTA** Los iconos con estrella alrededor de la fase lunar se mostrarán a partir de las 6 de la tarde hasta las 6:00 de la mañana siguiente.

## ILUMINACIÓN DE FONDO

Pulse **LIGHT**(luz) para activar la iluminación de fondo durante 5 segundos.

## REINICIO

Pulse **RESET**(restaurar) para volver a la configuración predeterminada

## CONECTAR CON SU DISPOSITIVO MÓVIL

Puede configurar remotamente la estación meteorológica y leer la información meteorológica a través de Bluetooth® 4.0 utilizando un dispositivo móvil con la aplicación, que se puede descargar en la Apple Store y en Google Play Store. Para encontrar rápidamente la aplicación, escriba '**Weather@Home**' como palabra clave en el motor de búsqueda.

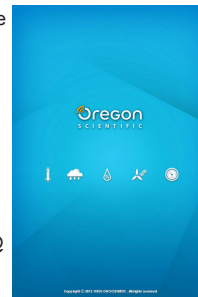

Asegúrese de que su teléfono móvil sea compatible con iOS 8 o Android 4.4 con Bluetooth® 4.0.

## ACOPLAMIENTO DE LA ESTACIÓN METEOROLÓGICA

En primer lugar, es necesario acoplar la estación meteorológica con el dispositivo móvil. El icono parpadeará en la pantalla de la estación meteorológica mientras se acopla y queda encendido después de un acoplamiento correcto.

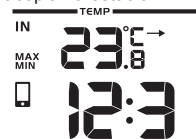

Pulse para permitir que la unidad principal se acople durante 30 segundos.



1. Abrir la aplicación, tocar **Conectar**. Se buscará automáticamente la estación meteorológica.
2. Una vez se ha emparejado con éxito, se mostrarán los números de emisoras y canales.
3. Pulse en cada canal para cambiar su nombre. (Están permitidos hasta 20 caracteres incluyendo espacios). Pulse **Done** si se completa. Pulse **<** para salir.

#### Para remover la estación meteorológica:

Pulse **Remove Station** (quitar estación) en **STATION**(estación) pantalla, la estación meteorológica se desconectará y los datos relacionados se suprimirán de la aplicación (App).

#### Para reubicar los sensores en la pantalla:

1. En la pantalla de **STATION**(estación), toque **☰**.
2. Pulse y mantenga pulsado **☰** en el lado derecho de un sensor. Arrastre a la posición deseada.
3. Toque **☰** para confirmar.



## CONFIGURACIÓN

Usted puede configurar características de su estación meteorológica a través de la aplicación, tales como unidades de medida.

#### Los criterios serán los siguientes:

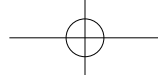

- Temperatura
- Presión barométrica
- Lluvia (no disponible en BAR218HGX)
- Velocidad del viento (no disponible en BAR218HGX)
- Altitud
- Mostrar sensor no disponible

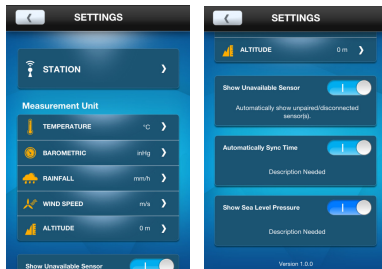

- Sincronizar automáticamente el tiempo
- Mostrar presión de nivel del mar



### Para seleccionar la unidad de medida

1. Toque  para ver las opciones de unidad de medida.
2. Toque la unidad deseada.
3. Toque  para volver a la pantalla anterior.

### Para ajustar la altitud:

La altitud refleja la distancia vertical desde el nivel del mar hasta su posición.

1. Complete la altitud en el blanco de su unidad principal.
2. Toque **Done**(finalizar).

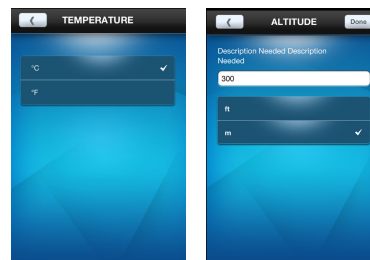

### VISUALIZACIÓN DE LAS LECTURAS CORRIENTES

Usted puede ver directamente al mismo tiempo todas las lecturas meteorológicas de diferentes sensores a través de la aplicación. Las lecturas están en la pantalla **HOME**(inicio).

**NOTA** Si el icono de batería baja  aparece en la pantalla, reemplace las pilas del dispositivo correspondiente.



#### Para mostrar sensor no disponible:

Si el sensor está fuera de rango, las lecturas se interrumpen y aparece en la pantalla - (dash mode). Si no desea que aparezca en pantalla el sensor que no está disponible:

- En la pantalla de **SETTINGS**(configuración) toque y deslice el botón hacia la derecha para activar la función, o deslice a izquierda para apagarlo.

#### Para sincronizar automáticamente la hora:

La hora y fecha de su estación meteorológica pueden ser sincronizadas automáticamente mediante el dispositivo móvil.

- En la pantalla de **SETTINGS**(configuración) toque y deslice el botón hacia la derecha para activar la función, o deslice a izquierda para apagarlo.

#### Para mostrar la presión a nivel del mar:

Después de que la altitud haya sido ingresada, puede ver la presión a nivel del mar en la pantalla de **HOME** (inicio).





- En la pantalla de **SETTINGS**(configuración) toque y deslice el botón hacia la derecha para activar la función, o deslice a izquierda para apagarlo.

**NOTA** Cuando altitud se ajusta a 0 metros, la lectura de la presión es la presión local. Si la altura se establece con la ubicación actual, la nueva lectura de la presión se muestra como una presión a nivel del mar.

#### VER HISTORIAL DE LECTURAS

Puede ver el historial a través de la aplicación. El historial también podría ser presentado en los gráficos (últimas 24 horas o últimos 7 días).

#### Para ver el historial

1. Toque en el área del sensor deseado en la pantalla.
2. Toque    para seleccionar los datos deseados o toque  para ordenar los datos por fecha.

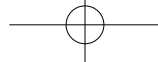

## PRECAUCIÓN

- Use sólo pilas nuevas del tamaño y tipo requeridos. No mezcle pilas viejas y nuevas, ni diferentes tipos de pilas.
- No tire las pilas gastadas en la basura doméstica. Es necesario recoger dichos residuos por separado para realizar un tratamiento especial posterior.
- Si cree que no va a utilizar el producto durante un largo periodo de tiempo, extráigale las pilas. Las pilas pueden derramar productos químicos que pueden dañar los componentes electrónicos.
- No exponga el producto a fuerza extrema, descargas, polvo, fluctuaciones de temperatura o humedad.

- No sumerja el dispositivo en agua. Si se vertiera líquido en la unidad, límpiela con un paño suave y sin electricidad estática.
- No limpie la unidad con materiales abrasivos o corrosivos.
- No manipule los componentes internos. De hacerlo se invalidaría la garantía.
- Las imágenes de esta guía para el usuario pueden ser distintas al producto en sí.
- Cuando elimine este producto, asegúrese de que no vaya a parar a la basura general, sino separadamente para recibir un tratamiento especial.
- Los contenidos de este manual no pueden reproducirse sin permiso del fabricante.

**NOTA** La ficha técnica de este producto y los contenidos de este manual de usuario pueden experimentar cambios sin previo aviso.

**NOTA** No todas las funciones y accesorios estarán disponibles en todos los países. Sírvase ponerse en contacto con su distribuidor local si desea más información. Por favor, visite <http://global.oregonscientific.com/customerSupport.php> para descargar una versión electrónica del manual de usuario.

**ESPECIFICACIONES**

TIPO	DESCRIPCIÓN
<b>UNIDAD PRINCIPAL</b>	
Largo x Ancho x Alto	7,32 x 3,7 x 2,13 pulg (186 x 94 x 54 mm)
Peso	223 g (7,87 onzas) sin pilas
Intervalo de temperaturas	-5°C a 50°C (23°F a 122°F)
Frecuencia de la señal	433 MHz
Rango de humedad	25% - 95%
Alimentación	3 pilas UM-3 (AA) 1.5V
Rango de temperatura por alerta de hielo	3°C a -2°C

**UNIDAD REMOTA (THGR511)**

L X A X A	96 x 50 x 22 mm (3,78 x 1,97 x 0,87 pulgadas)
Peso	49 g (1.7 onzas)
Cobertura de transmisión	30 m (98 pies) sin obstáculos
Rango de temperatura	-20 °C a 60 °C (-4 °F a 140 °F)
Alimentación	2 pilas UM-4 (AAA) de 1,5V

**SOBRE OREGON SCIENTIFIC**

Visite nuestro sitio web [www.oregonscientific.com](http://www.oregonscientific.com) para obtener más información sobre los productos de Oregon Scientific.

Si tiene alguna duda, póngase en contacto con nuestros servicios al cliente en [info@oregonscientific.com](mailto:info@oregonscientific.com).

Oregon Scientific Global Distribution Limited se reserva el derecho de interpretar e inferir cualquier contenido, términos y provisiones de este manual de usuario y corregirlo, a su discreción en cualquier momento y sin aviso previo. Si hubiese alguna divergencia entre la versión en inglés y las versiones de otros idiomas, prevalecerá la versión en inglés.





## EU - DECLARACIÓN DE CONFORMIDAD

Por la presente el fabricante, Oregon Scientific Global Distribution Limited, declara que el tipo de radio equipo Estación Meteorológica Weather@Home con Bluetooth (Modelo: BAR218HGX) está en el cumplimiento de la Directiva 2014/53/UE. El texto completo de la declaración de conformidad de la UE está disponible en la siguiente dirección de Internet:

<http://global.oregonscientific.com/customerSupport.php>



### PAÍSES BAJO LA DIRECTIVA RED

Todos los países de la UE, Suiza   
y Noruega 

## INFORMACIÓN DE USUARIOS



**Según las Directrices Europeas 2011/65/EU y 2012/19/EU, relativas a la reducción del uso de sustancias peligrosas en los aparatos eléctricos y electrónicos, además del desecho de los residuos.**

El símbolo tachado del contenedor que se encuentra en el aparato indica que el producto, al final de su vida útil, deberá depositarse en un lugar separado de los demás residuos. Por lo tanto, el usuario deberá entregar el aparato, cuando deje de utilizarse, a los adecuados centros de recogida diferenciada de residuos electrónicos y electrotécnicos, o deberá devolverlo al vendedor en el momento de compra de un nuevo aparato de tipo equivalente, uno a cambio de otro.

La adecuada recogida diferenciada del aparato inutilizado para el sucesivo reciclaje, tratamiento y desecho ambientalmente compatibles, contribuye a evitar posibles efectos negativos en el medioambiente y en la salud, y favorece el reciclaje de los materiales de los que se compone el aparato.

El desecho abusivo del producto por parte del usuario implica la aplicación de las sanciones previstas por la ley.





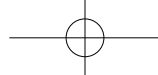

POR

**Weather@Home**  
**Estação Meteorológica Bluetooth**  
**Model: BAR218HGX**

Manual de Usuário

**ÍNDICE**

**Introdução**.....2

**Visão Geral**.....2

    Vista Posterior.....2

    Vista Anterior.....3

    Sensor Remoto.....3

**Inicialização** .....3

    Inserir Baterias .....3

**Sensor Remoto**.....4

    Transmissão De Dados Do Sensor.....4

**Relógio** .....5

    Acerto Manual Do Relógio .....5

**Previsão Meteorológica** .....5

**Mensagem De Alerta De Mau Tempo**.....5

**Temperatura E Umidade**.....6

    Alerta De Gelo.....6

    Tendências Meteorológicas .....6

**Fases Da Lua**.....6

**Retro-iluminação**.....6

**Reset**.....7

**Ligar Com O Seu Dispositivo Móvel** .....7

    Emparelhando A Sua Estação Meteorologica.....7

    Configurações.....8

    Visualizar Leituras Actuais .....9

    Visualizar Histórico De Leituras.....10

**Precauções** .....10

**Especificações** .....11

**Sobre A Oregon Scientific** .....11

**Declaração De Conformidade Da Ue**.....12

**Declaração de conformidade** .....12

## INTRODUÇÃO

Obrigado por escolher Oregon Scientific™ Weather@Home Estação Meteorológica Bluetooth.

**NOTA** Por favor, mantenha este manual acessível enquanto usa o seu novo produto. Contém práticas instruções passo a passo, assim como especificações técnicas e avisos sobre os quais deve ter conhecimento.

## VISÃO GERAL

### VISTA POSTERIOR

1. Indicador de recepção do sensor remoto e canal exterior selecionado
2. : pilha fraca no sensor remoto exterior
3. : Previsão meteorológica e tendência de pressões para as próximas 12 horas
4. : mensagem de alerta de mau tempo
5. Leitura de temperatura interior (atual/**MAX** (MAX)/**MIN** (MIN)) com tendência de temperatura
6. indicador de ligação BLE
7. : pilha fraca na unidade principal
8. Indicador LED de alerta de gelo
9. **MODE** (MODO): mudar configurações / tela
10. **MEM** (MEMÓRIA): visualizar temperatura / umidade atual, máxima e mínima

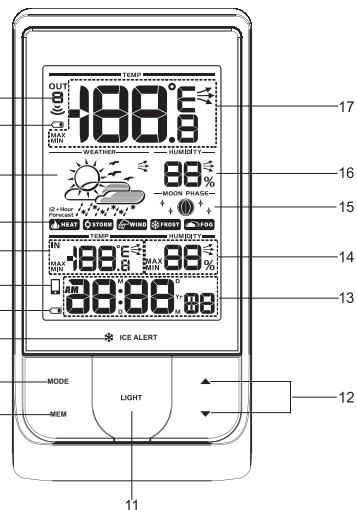

11. **LIGHT** (LUZ): ativar retroiluminação
12. / : aumentar / diminuir valor das configurações; alternar apenas o botão para selecionar os canais exteriores (1-3); desativar / desativar modo de emparelhamento.
13. **AM/PM**: manhã/tarde  
**MD/DM/Yr**: calendário / relógio com dias da semana (horas: minutos na segunda visualização)

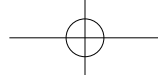

14. Leitura de umidade interior (atual/**MAX** (MAX)/**MIN** (MIN)) com tendência de umidade
15. Visualização da fase da lua
16. Umidade exterior (atual/**MAX** (MAX)/ **MIN** (MIN)) com tendência de umidade
17. Leitura de temperatura exterior (atual/**MAX** (MAX)/ **MIN** (MIN)) com tendência de temperatura

#### VISTA ANTERIOR

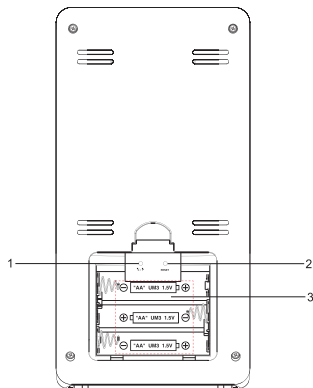

1. °C / °F: selecionar unidade de temperatura
2. **RESET** (REINICIALIZAR): Reinicializar a unidade para as configurações de fábrica

3. Compartimento de pilhas

#### SENSOR REMOTO

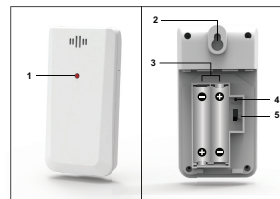

1. Indicador LED de status
2. Orifício para montagem em parede
3. Compartimento de pilhas
4. Orifício de **RESET**
5. Interruptor **CHANNEL**

#### INICIALIZAÇÃO

##### INSERIR BATERIAS

1. Abrir o compartimento das pilhas.
2. Inserir pilhas, fazendo corresponder as polaridades (+/-).
3. Pressionar **RESET** (REINICIALIZAR) depois de cada mudança de pilhas.

 LOCALIZAÇÃO	SIGNIFICADO
Área do Relógio / alarme	Pilhas fracas na unidade principal
Área da Temperatura Exterior	Pilhas fracas no Sensor

### SENSOR REMOTO

A unidade principal pode receber informação de até 3 sensores.

#### Para instalar o sensor:

1. Abrir o compartimento para pilha.
2. Selecionar um canal e pressionar **RESET** (REINICIALIZAR).
3. Fechar o compartimento da pilha.
4. Colocar o sensor a uma distância até 98 pés (30 m) da unidade principal usando o suporte vertical ou fixando-o na parede.

**DICA** As localizações ideais para o sensor são em qualquer local no exterior da casa a uma altura não maior que 5 pés (1,5 m) e onde possa estar abrigado da luz solar direta ou da chuva para uma leitura precisa.

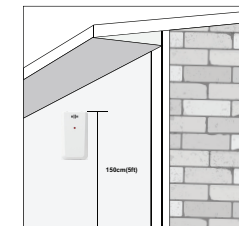



**NOTA** Usar pilhas alcalinas para uma utilização mais longa e pilhas de lítio para temperaturas abaixo do ponto de congelação.

### TRANSMISSÃO DE DADOS DO SENSOR

#### Para procurar um sensor:

Pressione e mantenha **▲** e **MODE** (MODO) ao mesmo tempo.

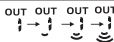
O ícone de recepção do sensor na área do sensor remoto mostra o estado:

ÍCONE	DESCRIÇÃO
	A unidade principal está a procurar o sensor
	Foi encontrado um canal
	O sensor não foi encontrado

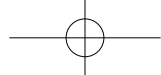

**DICA** O alcance da transmissão pode depender de vários fatores. Poderá ter que experimentar várias localizações para conseguir os melhores resultados.

## RELÓGIO

### ACERTO MANUAL DO RELÒGIO

1. Pressionar e manter **MODE** (MODO).
2. Pressionar ▲ ou ▼ para alterar as configurações
3. Pressionar **MODE**(MODO) para confirmar.
4. A ordem das configurações é: formato 12/24 horas, hora, minuto, dia, formato do calendário (dia-mês/mês-dia), mês, dia e idioma.

As opções de idioma são Inglês (**E**), Alemão (**D**), Francês (**F**), Italiano (**I**), e Espanhol (**S**).

**Para selecionar o modo de visualização:**  
Alternar **MODE** (MODO) para escolher entre relógio com segundos / dia da semana / calendário / fase da lua.

### PREVISÃO METEOROLÓGICA

Este produto prevê as condições meteorológicas das próximas 12 horas num raio de 19 a 31 milhas (30 a 50 km).

	Sol
	Parcialmente Nublado
	Nublado
	Chuva
	Neve

### MENSAGEM DE ALERTA DE MAU TEMPO

As mensagens de alerta de mau tempo fornecem indicações de circunstâncias de ocorrência provável baseadas nos cálculos da estação meteorológica. Os significados das mensagens são ilustrados abaixo:

WARNING	MENSAGEM
	Risco de temperaturas elevadas
	Risco de ventos fortes
	Risco de tempestade
	Risco de nevoeiro
	Risco de gelo ou geada

## TEMPERATURA E UMIDADE

### Para seleccionar a unidade de temperatura:

- Seleccionar °C ou °F para leituras de temperatura com um alfinete ou o bico de uma caneta.

### Para seleccionar as leituras de um sensor exterior:

- Alternar ▲ para seleccionar a leitura pretendida para o sensor.

### Para pesquisar automaticamente pelos sensores:

- Pressionar e manter ▼ e MEM (MEMÓRIA) para visualizar os dados de cada sensor durante 3 segundos.
- Para terminar, pressionar ▲ .

### Para visualizar os registos diários actuais, mínimos e máximos para um sensor seleccionado:

- Alternar MEM (MEMÓRIA).

### Para limpar os registos:

- Pressionar e manter MEM (MEMÓRIA).

## ALERTA DE GELO

Se o sensor do canal 1 cair de 37°F para 28°F (3°C para -2°C), o indicador LED piscará, e deixará de piscar assim que a temperatura sair deste intervalo.

- Pressionar simultaneamente e para desdesativar o alerta de gelo.

**NOTA** Como o alerta de gelo só é aplicável para o canal 1, para evitar que o LED pisque, seleccione o canal 2 ou 3 para um sensor exterior.









## TENDÊNCIAS METEOROLÓGICAS

Os ícones de tendência de temperatura, umidade e pressão atmosférica baseiam-se nas leituras recentes dos sensores.

RISE	STEADY	FALL
		

## FASES DA LUA

No modo de fases da lua, pressionar ▲ ou ▼ para seleccionar o ano pretendido (de 2001 a 2099).

	Lua nova		Lua cheia
	Lua crescente		Lua balsâmica
	Quarto crescente		Quarto minguante
	Lua gibba		Lua minguante

**NOTA** Os ícones de Estrelas à volta da fase da lua serão apresentados das 6 horas da tarde até às 6 horas da manhã seguinte.

## RETRO-ILUMINAÇÃO

Pressionar LIGHT (LUZ) para desativar a retroiluminação durante 5 segundos.



## RESET

Pressionar **RESET** (REINICIAR) para voltar para as configurações de fábrica.

## LIGAR COM O SEU DISPOSITIVO MÓVEL

Poderá definir remotamente a sua estação meteorológica e ler a informação meteorológica através de Bluetooth® 4.0 usando o seu dispositivo móvel com a aplicação transferível da Loja Apple e da Loja Google Play. Para encontrar rapidamente a aplicação, insira **'Weather@Home'** como palavra-chave no motor de busca.



Garanta que o seu dispositivo móvel é compatível com iOS 8 ou Android 4.4 com Bluetooth® 4.0.

## EMPARELHANDO A SUA ESTAÇÃO METEOROLÓGICA

Antes de tudo, deverá emparelhar a sua estação meteorológica com o seu dispositivo móvel.  piscará no tela da estação meteorológica durante

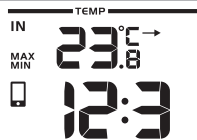

o emparelhamento e ficará visível após um emparelhamento bem-sucedido.

Pressionar  para permitir um emparelhamento com a unidade principal durante 30 segundos.

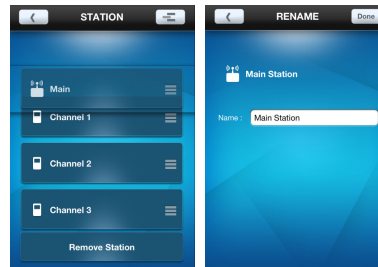



1. Abra o aplicativo e toque em **Ligar** para procurar pela estação de tempo automaticamente.
2. Assim que emparelhar com sucesso, os números da estação e canal serão exibidos.
3. Toque em cada um dos canais para mudar o nome. (São permitidos até 20 caracteres, incluindo espaços.) Toque em **Done** se tiver terminado. Toque em  para sair.

### Para remover a estação de tempo:

TOCAR em **Remove Station** (Remover estação) no tela **STATION** (ESTAÇÃO), a estação de tempo será desemparelhada e os seus dados serão removidos do aplicativo.

### Para reposicionar os sensores no tela:

1. No tela **STATION** (ESTAÇÃO), tocar em .
2. Pressionar e manter  no lado direito de um sensor. Arrastá-lo até à posição desejada.
3. Tocar em  para confirmar.



## CONFIGURAÇÕES

Poderá configurar a sua estação meteorológica através da aplicação, por exemplo para as unidades de medida.



As configurações são as seguintes:

- Temperatura
- Barométricas
- Precipitação (não disponível no BAR218HGX)
- Velocidade do vento (não disponível no BAR218HGX)

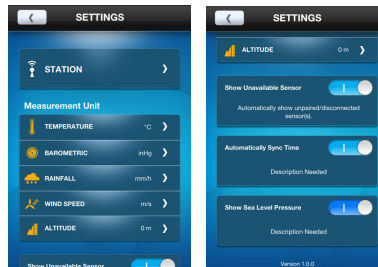
- Altitude
- Mostrar Sensor Indisponível
- Sincronia Automática da Hora
- Mostrar Pressão ao Nível do Mar



Para seleccionar a unidade de medida:

1. Tocar em  para visualizar as opções de unidade de medida.
2. Tocar na unidade desejada.
3. Tocar em  para voltar ao tela anterior.

### Para definir a altitude:

A altitude reflecte a distância entre o nível do mar e a sua posição.

1. Preencher a altitude da sua unidade principal no espaço disponível.
2. Tocar em **Done** (Feito).



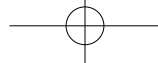

POR

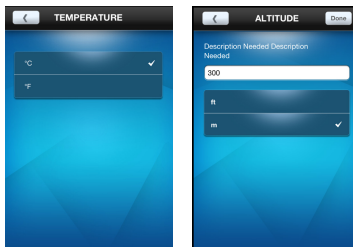

## VISUALIZAR LEITURAS ACTUAIS

Poderá visualizar diretamente todas as leituras meteorológicas provenientes dos diferentes sensores através da aplicação num dado momento. As leituras estão no tela **HOME** (INÍCIO).

**NOTA** Se o ícone de pilhas fracas  aparecer no tela, por favor substitua as pilhas do dispositivo correspondente.

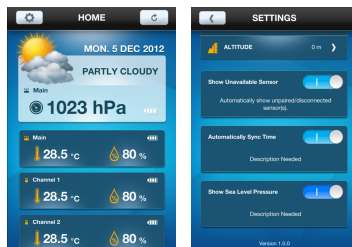

### Para mostrar sensores indisponíveis:

Se o sensor estiver fora do alcance, as leituras serão interrompidas e — (travessão) aparecerá no tela. Se não pretender mostrar o sensor indisponível:

- No tela **SETTINGS** (DEFINIÇÕES), toque e deslize o botão para a direita para ligar a função, ou deslize para a esquerda para a desligar.

### Para sincronizar automaticamente a hora:

A hora e a data da sua estação meteorológica podem ser automaticamente sincronizadas pelo seu dispositivo móvel.

- No tela **SETTINGS** (DEFINIÇÕES), toque e deslize o botão para a direita para ligar a função, ou deslize para a esquerda para a desligar.

### Para mostrar a pressão ao nível do mar:

Depois de introduzir a altitude, poderá visualizar a pressão ao nível do mar no tela **HOME** (INÍCIO).

- No tela **SETTINGS** (DEFINIÇÕES), toque e deslize o botão para a direita para ligar a função, ou deslize para a esquerda para a desligar.







**NOTA** Quando a altitude for definida como 0 metros, a leitura de pressão é a da pressão local. Se a altitude for definida para a localização atual, a nova leitura de pressão será visualizada como a pressão ao nível do mar.

## VISUALIZAR HISTÓRICO DE LEITURAS

Poderá visualizar o histórico de leituras através da aplicação. O histórico também poderá ser apresentado em gráficos (das últimas 24 horas ou dos últimos 7 dias).

Para visualizar o histórico:

1. Tocar na área do sensor pretendido no tela.
2. Tocar em    para seleccionar os dados pretendidos ou tocar em  para ordenar os dados por data.



## PRECAUÇÕES

- Use apenas pilhas novas do tamanho e tipo especificados. Não misture pilhas novas e usadas ou de diferentes tipos.

- Não coloque as pilhas usadas no lixo. Este tipo de lixo necessita de tratamento especial.
- Se você não planeia usar o unidade por um longo período de tempo, remova as pilhas. As pilhas podem verter químicos que podem danificar as partes eletrônicas.
- Não submeta a unidade a forças excessivas, impactos, poeiras, oscilações de temperatura ou umidade.
- Não mergulhe a unidade na água. Se respingar líquido nela, seque-a imediatamente com um pano macio e que não solte fiapos.
- Não limpe a unidade com material abrasivo ou corrosivo.
- Não altere os componentes internos da unidade. Isso invalidará sua garantia.
- As imagens mostradas neste manual podem diferir da imagem real.
- Os materiais utilizados nos produtos Oregon podem ser reutilizados e reciclados após o fim de sua vida útil. Encaminhe os produtos a serem descartados aos locais de coleta apropriados, atentando para as legislações locais.
- O conteúdo deste manual não pode ser reproduzido sem a permissão do fabricante.

**NOTA** As especificações técnicas deste produto e o conteúdo do manual do usuário estão sujeitos a alterações sem aviso prévio.

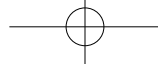

**NOTA** Recursos e acessórios não estão disponíveis para todos os países. Para obter mais informações, entre em contato com o seu distribuidor local. Para descarregar uma versão eletrônica do manual de utilizador, por favor visite <http://global.oregonscientific.com/customerSupport.php>.

## ESPECIFICAÇÕES

TIPO	DESCRIÇÃO
<b>UNIDADE PRINCIPAL</b>	
C x L x A	7,32 x 3,7 x 2,13 in (186 x 94 x 54 mm)
Peso	223 g (7,87onças) sem pilhas
Intervalo de Temperaturas	-5°C a 50°C (23°F a 122°F)
Frequência do Sinal	433 MHz
Intervalo de Umidade	25% - 95%
Alimentação	3 pilhas UM-3 (AA) 1,5V
Amplitude térmica para alerta de gelo	3°C até -2°C

## UNIDADE REMOTA (THGR511)

C x L x A	96 x 50 x 22 mm (3,78 x 1,97 x 0,87 pol)
Peso	49g (1,7 onças)
Faixa de transmissão	30m (98 pés) sem obstrução
Faixa de temperatura	-20 °C a 60 °C (-4 °F a 140 °F)
Alimentação	2 pilhas UM-4 (AAA) de 1,5V

## SOBRE A OREGON SCIENTIFIC

Visite o nosso website [www.oregonscientific.com.br](http://www.oregonscientific.com.br) para saber mais sobre os produtos da Oregon Scientific.

Para colocar qualquer tipo de questão, contacte o nosso Serviço de Apoio ao Cliente através do endereço [sac@oregonscientific.com.br](mailto:sac@oregonscientific.com.br).

Para maiores informações, contactar o SAC - Serviço de Atendimento a Cliente - (11) 3523-1934 ou email: [sac@oregonscientific.com.br](mailto:sac@oregonscientific.com.br).

A Oregon Scientific Global Distribution Limited reserva o direito de interpretar e definir quaisquer conteúdos, termos e disposições neste manual do usuário, e de o modificar a seu exclusivo critério, em qualquer altura e sem aviso prévio.

No caso de existir alguma inconsistência entre a versão em inglês e as outras versões noutras línguas, a versão em inglês prevalecerá.



## DECLARAÇÃO DE CONFORMIDADE DA UE

Com isso o fabricante, Oregon Scientific Global Distribution Limited, declara que o tipo de rádio equipmment Weather@Home Estação Meteorológica Bluetooth (Model: BAR218HGX) está em conformidade com a Directiva 2014/53/UE. O texto integral da Declaração de Conformidade da UE está disponível no endereço Internet seguinte:

<http://global.oregonscientific.com/customerSupport.php>



### PAÍSES SUJEITOS À NORMA RED

Todos os países da União Européia, Suíça  e Noruega 

## INFORMAÇÕES AOS UTENTES



**Nos termos das Diretivas Europeias 2011/65/EU e 2012/19/EU, relativas à redução do uso de substâncias perigosas nos aparelhos elétricos e eletrônicos, além da eliminação de resíduos sólidos.**

O símbolo da lata de lixo traçada indicada no aparelho significa que o produto ao fim de sua vida útil, deverá ser eliminado separadamente de outros resíduos sólidos.

O consumidor deverá, portanto, entregar o aparelho após o término de sua vida útil, aos centros encarregados pela coleta diferenciada de resíduos eletrônicos e eletrotécnicos, ou mesmo, entregá-lo de volta ao revendedor no momento da compra de um novo aparelho de tipo equivalente, na proporção de um para um.

A coleta diferenciada adequada para a eliminação sucessiva do aparelho fora de uso a ser reciclado, para o tratamento do lixo em modo compatível com o ambiente, contribui para evitar possíveis efeitos negativos ao meio ambiente e à saúde e facilita a reciclagem dos materiais dos quais o aparelho é constituído.

A eliminação do produto sem respeitar as normas por parte do consumidor implica na aplicação das sanções de acordo com as leis vigentes.

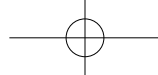

NL

**Weather@Home**  
**Weerstation met Bluetooth-functie**  
**Model: BAR218HGX**  
 User Manual

**INHOUD**

**Inhoudsopgave** .....2

**Overzicht** .....2

  Voorraanzicht .....2

  Achteraanzicht .....3

  Remotesensor .....3

**Aan De Slag** .....3

  Plaats De Batterijen .....3

**Remotesensor** .....4

  Sensor Gegevenstransmissie .....4

**Klok** .....5

  Klok Handmatig Instellen .....5

**Weersverwachting** .....5

**Weer Waarschuwingsmelding** .....5

**Temperatuur En Vochtigheid** .....6

  Vorstwaarschuwing .....6

  Weer Trends .....6

**Maanstand** .....6

**Verlichting** .....7

**Resetten** .....7

**Aansluiten Op Uw Mobiele Apparaat** .....7

  Uw Weerstation Koppelen .....7

  Instellingen .....8

  Huidige Aflezingen Bekijken .....9

  Geschiedenis Van Metingen Bekijken .....10

**Waarschuwingen** .....10

**Specificaties** .....11

**Over Oregon Scientific** .....11

**EU Conformiteits Verklaring** .....12

**Informatie Voor de Gebruikers** .....12

## INHOUDSOPGAVE

Dank u voor het kiezen van onze Oregon Scientific Weather@Home Weerstation met Bluetooth-functie. Daarnaast wordt het ook uitgevoerd de veranderlijke weergave tussen binnen-en buitentemperatuur.



**NB** Houd deze handleiding bij de hand terwijl u uw nieuwe product gebruikt. De handleiding bevat praktische stap-voor-stap instructies, evenals de technische specificaties en belangrijke waarschuwingen.

## OVERZICHT

### VOORAANGEZICHT

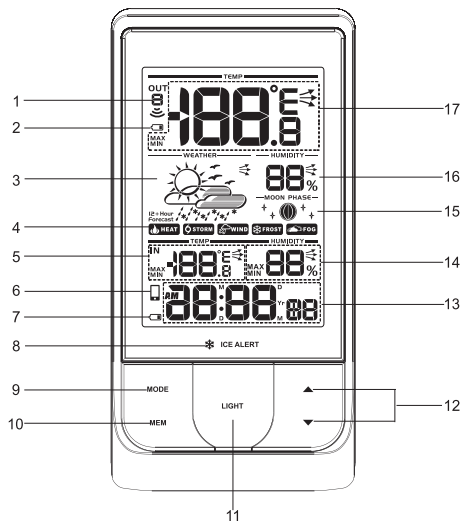
1. Indicator sensorontvanger en buitenkanaal geselecteerd
2. : batterij afstandssensor buiten is zwak
3. : Weerbericht en luchtdruk trend voor komende 12 uur
4.     : melding weerwaarschuwing
5. Binnentemperatuur aanduiding (huidige **MAX/MIN**) met temperatuur trend
6. : BLE-verbindingsindicator
7. : batterij hoofdapparaat zwak
8. LED-indicator vorstalarm
9. **MODE** (MODUS): instellingen wijzigen/display



10. **MEM** (GEHEUGEN): Bekijk huidige, maximum en minimum temperatuur/luchtvochtigheid
11. **LIGHT** (VERLICHTING): activeer verlichting
12.  / : instellingswaarden verhogen/verlagen; gebruik alleen de  toets om buitenkanalen te selecteren (1-5); koppelingsmodus activeren/uitschakelen.

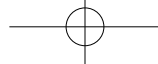

13. **AM/PM:** 's morgens/'s middags  
**MD/DM/Jaar:** kalender/klok met weekdag  
(uur: minuut met secondewijzer)
14. Aanduiding luchtvochtigheid binnen (huidige/**MAX**/**MIN**) met luchtvochtigheid trend
15. Maanfaseweergave
16. Luchtvochtigheid buiten (huidige/**MAX**/**MIN**) met luchtvochtigheid trend
17. Buitentemperatuur aanduiding (huidige/**MAX**/**MIN**) met temperatuur trend

#### ACHTERAANZICHT

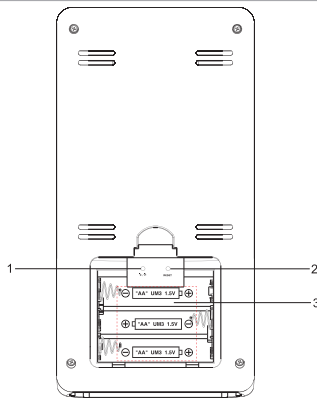

1. °C / °F: selecteer temperatuureenheid
2. **RESET** (RESETTEN): het apparaat resetten naar standaardinstellingen
3. Batterijcompartment

#### REMOTESENSOR

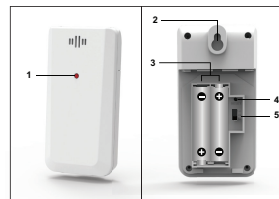

1. Statusindicator LED
2. Muurbevestigingsgat
3. Batterijvak
4. **RESET** gat
5. **KANAAL** schakelaar

#### AAN DE SLAG

##### PLAATS DE BATTERIJEN

1. Verwijder de batterijhouder.
2. Plaats de batterijen met de juiste polariteit (+/-).

3. Druk na het vervangen van de batterijen altijd op **RESET** (RESETTEN).

 <b>PLAATS</b>	<b>BETEKENIS</b>
Klok/alarm aanduiding	Batterijen hoofddapparaat zwak
Buitentemperatuur aanduiding	Batterijen sensor zwak

## REMOTESENSOR

Het hoofddapparaat kan gegevens van maximaal 5 sensoren registreren.

### De sensor instellen:

1. Open het batterijcompartiment.
2. Selecteer een kanaal en druk op **RESET** (RESETTEN).
3. Sluit de batterijklep.
4. Plaats de sensor binnen 30 meter van het basisstation met de tafelstandaard of wandmontage.

**TIP** De ideale plek voor de sensor is een locatie aan de buitenzijde van de woning op een hoogte van niet meer dan 1,5 meter waar het niet is blootgesteld aan direct zonlicht of regen. Dit om een goede meting te verzekeren.

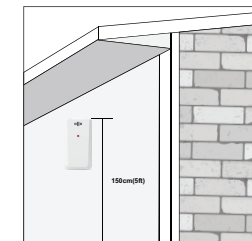



**NB** Gebruik alkalinebatterijen voor langdurig gebruik en lithium batterijen bij temperaturen onder het vriespunt.

## SENSOR GEGEVENSTRANSMISSIE

### Zoeken naar een sensor:

De **▲** en **MODE** (MODUS) toetsen gelijktijdig ingedrukt houden.

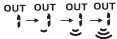
### De sensor ontvangstindicator geeft de status weer:

<b>PICTOGRAM</b>	<b>BESCHRIJVING</b>
	Het apparaat zoekt naar sensor(en).
	Een kanaal is gevonden.
	De sensor kan niet gevonden worden.



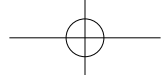

NL

**TIP** Het zendbereik kan variëren en is afhankelijk van diverse factoren. Het kan nodig zijn om te experimenteren met verschillende locaties om de beste resultaten te krijgen.

## KLOK

### KLOK HANDMATIG INSTELLEN

1. De **MODE** (MODUS) toets ingedrukt houden.
2. Druk op ▲ of ▼ om de instellingen te wijzigen.
3. Druk op **MODE** (MODUS) om te bevestigen.
4. De volgorde van instellingen is: 12/24 uur formaat, uren, minuten, jaar, kalenderformaat (dag-maand/maand-dag), maand, dag en taal.





De beschikbare talen zijn Engels (**E**), Duits (**D**), Frans (**F**), Italiaans (**I**) en Spaans (**S**).

### De displaymodus selecteren:

Gebruik **MODE** (MODUS) om te kiezen tussen klok met seconden/weekdag/kalender/maanfase.

## WEERSVERWACHTING

Dit apparaat voorspelt het weer voor de komende 12 uur in een radius van 30-50 km.

	Zonnig
	Half bewolkt
	Bewolkt
	Regen
	Sneeuw

## WEER WAARSCHUWINGSMELDING

De weer waarschuwingmeldingen geven een indicatie van mogelijke omstandigheden die zich kunnen voordoen op basis van berekeningen van het weerstation. De betekenissen van de waarschuwingen worden hieronder getoond:

WAARSCHUWING	MELDING
 <b>HEAT</b>	Kans op hoge temperaturen
 <b>WIND</b>	Kans op hoge windsnelheden
 <b>STORM</b>	Kans op storm
 <b>FOG</b>	Kans op mist
 <b>FROST</b>	Kans op ijsel

## TEMPERATUUR EN VOCHTIGHEID

### De temperatuuraanduiding selecteren:

- Select de **C°** of **F°** temperatuuraanduiding met een pen of puntig voorwerp.

### Aanduidingen van buitensensor instellen:

- Gebruik **▲** om de gewenste sensoraanduiding te selecteren.

### Automatisch naar sensoren zoeken:

- De **▼** en **MEM** (GEHEUGEN) gelijktijdig indrukken om de gegevens van elke sensor 3 seconden te tonen.
- Druk op **▲** om af te sluiten.

### De huidige, minimale en maximale gegevens van de dag van een geselecteerde sensor weergeven:

- Gebruik **MEM** (GEHEUGEN).

### De gegevens wissen:

- De **MEM** (GEHEUGEN) toets ingedrukt houden.

## VORSTWAARSCHUWING

Als de sensor op Kanaal 1 daalt van 37°F tot 28°F (3°C tot 2°C), knippert de LED-indicator. Het

knippen stopt wanneer de temperatuur weer buiten deze zone is.

- Druk gelijktijdig op **▲** en **▼** om de vorstwaarschuwing uit te schakelen.

**NB** De vorstwaarschuwing is alleen van toepassing op Kanaal 1. Selecteer Kanaal 2 of 3 op de buitensensor om te voorkomen dat de LED knippert.









## WEER TRENDS

De temperatuur, luchtvochtigheid en luchtdruktrend pictogrammen zijn gebaseerd op recente sensormetingen.

STIJGING	STABIEL	DALING
		

## MAANSTAND

Selecteer de maanstand-modus en druk op **▲** of **▼** om door de jaren (2001 tot 2099) te scannen.

	Nieuwe maan		Volle maan
	Wassende halve maan		Afnemende maan
	Eerste kwartaal		Derde kwartaal
	Wassende maan		Afnemende maan

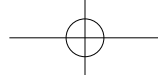

NL

**NB** Vanaf 6 uur 's avonds tot 6 uur de volgende ochtend worden ster-pictogrammen rond de maanfase getoond.

## VERLICHTING

Druk op **LIGHT** (VERLICHTING) om de verlichting 5 seconden in te schakelen.

## RESETTEN

Druk op **RESET** (RESETTEN) om terug te keren naar de standaardinstellingen.

## AANSLUITEN OP UW MOBILE APPARAAT

U kunt het weerstation op afstand bedienen en weersinformatie aflezen via Bluetooth® 4.0 met uw mobiele apparaat en de applicatie die u kunt downloaden van de Apple Store en Google Play Store. U kunt de applicatie snel vinden door 'Weather@Home' als zoekwoord in de zoekmachine in te voeren.

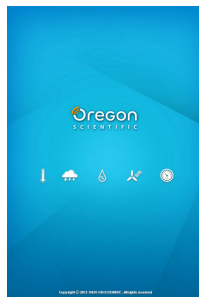

Zorg ervoor dat uw mobiele apparaat compatibel is met iOS 8 of Android 4,4 met Bluetooth® 4,0.

## UW WEERSTATION KOPPELEN

Allereerst moet u uw weerstation koppelen aan uw mobiele apparaat. Het pictogram  gaat knippen op het scherm van het weerstation tijdens het koppelen en blijft zichtbaar na de koppeling.

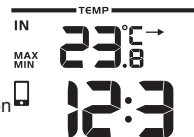

Als u op  drukt is de koppelingsmodus 30 seconden beschikbaar.

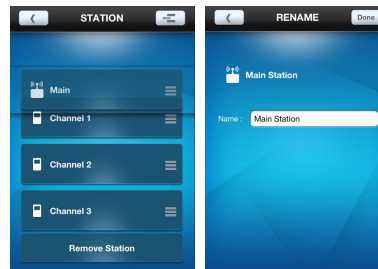



1. Open de App, tik op **Verbinden**. Het zal automatisch het weerstation zoeken.
2. Zodra het koppelen gelukt is, zullen het station en de kanaalnummers worden weergegeven.

- Tik op elk kanaal om het te hernoemen. (Tot 20 karakters met inbegrip van spaties zijn toegestaan). Tik op **Done** indien ingevuld. Tik op  om de instelling te verlaten.

#### De weerstation verwijderen:

Tikt u op **Remove Station** (Station verwijderen) op **STATION**, het weerstation wordt losgekoppeld en de gegevens worden verwijderd uit de app.

#### De sensoren op het scherm verplaatsen:

- Tik op het **STATION** scherm op .
- De toets  rechts van de sensor ingedrukt houden. Sleep het naar de gewenste positie.
- Tik op  om te bevestigen.



## INSTELLINGEN

Met de applicatie kunt u instellingen op uw weerstation veranderen, bijvoorbeeld de meeteenheden.

#### De instellingen zijn als volgt:

- Temperatuur
- Barometer
- Neerslag (niet beschikbaar in BAR218HGX)
- Windsnelheid (niet beschikbaar in BAR218HGX)
- Hoogte
- Toon onbeschikbare sensor
- Automatische tijdsynchronisatie
- Toon druk op zeeniveau

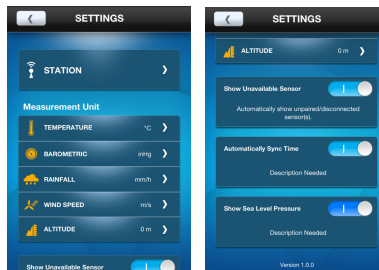

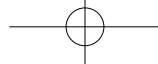

### De meeteenheid selecteren:

1. Tik op om de beschikbare meeteenheden te bekijken.
2. Tik op de gewenste eenheid.
3. Tik op om terug te gaan naar het vorige scherm.

### De hoogte instellen:

De hoogte toont het verschil tussen zeeniveau en uw locatie.

1. De hoogte van uw apparaat in de lege ruimte invullen.
2. Tik op **Done** (Klaar).

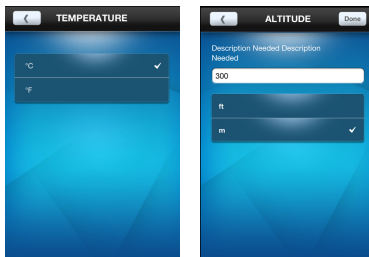

## HUIDIGE AFLEZINGEN BEKIJKEN

U kunt alle weersgegevens van de verschillende sensoren via de toepassing bekijken. De gegevens zijn toegankelijk in het **HOME** (BEGIN) scherm.

**NB** Als het batterijpictogram op het scherm verschijnt, moeten de batterijen voor het betreffende apparaat worden vervangen.



### Onbeschikbare sensor tonen:

Als de sensor buiten bereik is, worden de meetwaarden onderbroken en verschijnt — (streepjesmodus) op het scherm. Als u onbeschikbare sensor niet wilt tonen:

- Ga naar **SETTINGS** (INSTELLINGEN) en versleep de toets naar rechts om deze functie in te schakelen en naar links om de functie uit te schakelen.

### De tijd automatisch synchroniseren:

Tijd en datum op uw weerstation kunnen automatisch worden gesynchroniseerd met uw mobiele apparaat.

- Ga naar **SETTINGS** (INSTELLINGEN), en versleep de toets naar rechts om deze functie in te schakelen en naar links om de functie uit te schakelen.

**Zeedrukniveau tonen:**

Na het invoeren van de hoogte, kunt u de druk op zeeniveau bekijken via het **HOME** (BEGIN) scherm.



- Ga naar **SETTINGS** (INSTELLINGEN), en versleep de toets naar rechts om deze functie in te schakelen en naar links om de functie uit te schakelen.

**NB** Wanneer de hoogte is ingesteld op 0 meter, is de drukmeting de lokale druk. Als de hoogte is ingesteld op de huidige locatie, wordt de nieuwe drukmeting weergegeven als druk op zeeniveau.

**GESCHIEDENIS VAN METINGEN BEKIJKEN**

U kunt de geschiedenis van metingen bekijken via de applicatie. De geschiedenis kan ook worden weergegeven in grafieken (de afgelopen 24 uur of 7 dagen).

**De geschiedenis bekijken:**

1. Tik op het gewenste sensorgebied op het scherm.
2. Tik op    om de gewenste gegevens te selecteren of tik op  om de gegevens op datum te sorteren.



DATE	MIN	MAX
MON 4 DEC	10.5°C	34°C
SUN 3 DEC	10.5°C	34°C
SAT 2 DEC	10.5°C	34°C
FRI 1 DEC	10.5°C	34°C
THU 30 NOV	10.5°C	34°C
WED 29 NOV	10.5°C	34°C
TUE 28 DEC	10.5°C	34°C

**WAARSCHUWINGEN**

- Gebruik alleen nieuwe batterijen van de juiste grootte en het juiste type. Gebruik geen oude en nieuwe batterijen of batterijen van verschillende types samen.
- Gooi oude batterijen niet bij het gewone huisvuil. Een afzonderlijke ophaling en speciale verwerking is vereist.
- Als u de product niet langdurig gebruikt, verwijder dan de batterijen. Batterijen kunnen chemicaliën lekken die de elektronische onderdelen kunnen schaden.
- Stel het apparaat niet bloot aan extreme klappen, schokken, stof, temperatuur of vochtigheid.
- Dompel het product nooit onder in water. Als u water over het apparaat morst, droog het dan onmiddellijk af met een zachte stoffvrije doek.

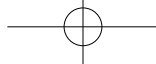

- Reinig het apparaat niet met krassende of bijtende materialen.
- Laat de interne componenten met rust. Anders kan dit de garantie beïnvloeden.
- De in deze handleiding weergegeven plaatjes kunnen afwijken van de werkelijkheid.
- Wanneer u dit product weg gooit, zorg dan dat het opgehaald wordt door de daarvoor bestemde afvaldienst.
- De inhoud van deze handleiding mag niet worden vermenigvuldigd zonder toestemming van de fabrikant.

**NB** De technische specificaties van dit product en de inhoud van de handleiding zijn zonder voorafgaande waarschuwing aan veranderingen onderhevig.

**NB** Niet alle functies en accessoires zijn beschikbaar in alle landen. Neem contact op met uw plaatselijke verkooppunt voor meer informatie. U kunt een elektronische versie van deze handleiding downloaden op <http://global.oregonscientific.com/customerSupport.php>.

## SPECIFICATIES

TYPE	BESCHRIJVING
<b>HOOFDEENHEID</b>	
L x B x H	7,32 x 3,7 x 2,13 in 186 x 94 x 54 mm

Gewicht	223 g (7,87ounces) zonder batterij
Temperatuurbereik	-5°C tot 50°C (23°F tot 122°F)
Signaal frequentie	433 MHz
Luchtvochtigheidsbereik	25% - 95%
Voeding	3 x UM-3 (AA) 1,5 V batterijen
Temperatuurbereik voor IJswaarschuwing	3 °C tot -2 °C

### BUITENSENSOR (THGR511)

L x B x H	96 x 50 x 22 mm (3,78 x 1,97 x 0,87 in)
Gewicht	49g (1,7 ounces)
Zendbereik	30 m (98 ft) in open ruimte
Temperatuurbereik	-20 °C tot 60 °C (-4 °F tot 140 °F)
Voeding	2 x UM-4 (AAA) 1,5V batterijen

## OVER OREGON SCIENTIFIC

Bezoek onze website [www.oregonscientific.com](http://www.oregonscientific.com) voor meer informatie over de producten van Oregon Scientific. Mocht u vragen hebben, neem dan contact op met onze klantenservice op [info@oregonscientific.com](mailto:info@oregonscientific.com).

Oregon Scientific Global Distribution Limited behoudt zich het recht voor enige inhoud, bepalingen en

voorwaarden in deze gebruikershandleiding te interpreteren en deze te allen tijde naar eigen inzicht en zonder voorafgaande kennisgeving te wijzigen. Met dien verstande dat, indien er enige inconsistentie bestaat tussen de Engelstalige versie en een versie in enige andere taal, de Engelse versie bindend is.



## EU CONFORMITEITS VERKLARING

Hierbij de fabrikant, Oregon Scientific Global Distribution Limited, verklaart dat de radio equipment soort Weather@Home Weerstation met Bluetooth-functie (Model: BAR218HGX) in overeenstemming is met 2014/53/EU-richtlijn. De volledige tekst van de verklaring van overeenstemming EU is beschikbaar op het volgende internetadres:

<http://global.oregonscientific.com/customerSupport.php>



### LANDEN DIE ONDERWORPEN AAN RED

Alle EU landen, Zwitserland   
en Noorwegen 

## INFORMATIE VOOR DE GEBRUIKERS



**Krachtens de EG-richtlijnen 2011/65/EU en 2012/19/EU met betrekking tot de beperking van het gebruik van bepaalde gevaarlijke stoffen in elektrische en elektronische apparatuur en de afdanking van deze apparatuur.**

Het symbool van de doorstreepte vuilnisbak aangebracht op de apparatuur geeft aan dat het product op het einde van zijn levensduur afzonderlijk van het ander afval afgedankt moet worden.

De gebruiker dient de apparatuur op het einde van zijn levensduur dus toe te vertrouwen aan een geschikt centrum voor de gescheiden verwerking van elektronisch en elektrotechnisch afval, of aan de verkoper te bezorgen bij de aankoop van een nieuwe apparatuur van gelijkaardig type, in de verhouding één tot één.

De correcte gescheiden omhaling voor de latere recyclage, verwerking en milieuvriendelijke vernietiging van de apparatuur draagt bij tot het voorkomen van mogelijke negatieve invloeden op het milieu en de gezondheid en bevordert de recyclage van de materialen waarvan de apparatuur samengesteld is.

De abusievelijk afdanking van het product vanwege de gebruiker geeft aanleiding tot de toepassing van administratieve boetes volgens de wetgeving.



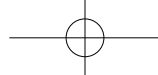

SWE

**Weather@Home**  
**Bluetooth-aktiverad väderstation**  
**Modell: BAR218HGX**  
Användarhandbok

**INNEHÅLL**

<b>Inledning</b> .....	2
<b>Översikt</b> .....	2
Framifrån.....	2
Bakifrån.....	3
Fjärrgivare.....	3
<b>Komma igång</b> .....	4
Sätt i batterier.....	4
<b>Fjärrgivare</b> .....	4
Sändning av givare data.....	4
<b>Klocka</b> .....	5
Manuellt inställd klocka.....	5
<b>Väderprognos</b> .....	5
<b>Väder varningsmeddelande</b> .....	5
<b>Temperatur och fuktighet</b> .....	5
Isvarning.....	6
Väderprognoser.....	6

<b>Månfaser</b> .....	6
<b>Bakgrundsbelysning</b> .....	6
<b>Återställ</b> .....	6
<b>Anslut till din mobila enhet</b> .....	7
Para ihop din väderstation.....	7
Inställningar.....	8
Visa aktuella mätningar.....	9
Visa avläsningshistorik.....	10
<b>Försiktighetsåtgärder</b> .....	10
<b>Specifikationer</b> .....	11
<b>Om Oregon Scientific</b> .....	11
<b>EU-Försäkrän om överensstämmelse</b> .....	11
<b>Information Till Alla Användare</b> .....	12

## INLEDNING

Tack för att du väljer vår Weather@Home Bluetooth-aktiverad väderstation från Oregon Scientific™. Enheten har en ändringsbar skärm som visar inomhus- och utomhustemperaturer samt fuktighet.

**NOTERA** Ha den här manualen till hands medan du använder din nya produkt. Manualen innehåller praktiska anvisningar steg för steg liksom tekniska specifikationer och varningar som du bör känna till.

## ÖVERSIKT

### FRAMIFRÅN

1. Indikator för fjärrgivare mottagning och vald utomhuskanal
2. : svagt batteri utomhus fjärrsensor
3. **12+ Hour Forecast**: Nästa 12 timmars väderprognos och trycktrend
4. **HEAT** / **STORM** / **WIND** / **FROST** / **FOG**: väder varningsmeddelande
5. Inomhustemperatur (aktuell/**MAX**/**MIN**) med temperaturtrend
6. anslutning av BLE-indikator
7. : låg batterispänning på huvudenhet
8. LED-indikator för isvarning
9. **MODE (VAL)**: ändra inställningar / skärm

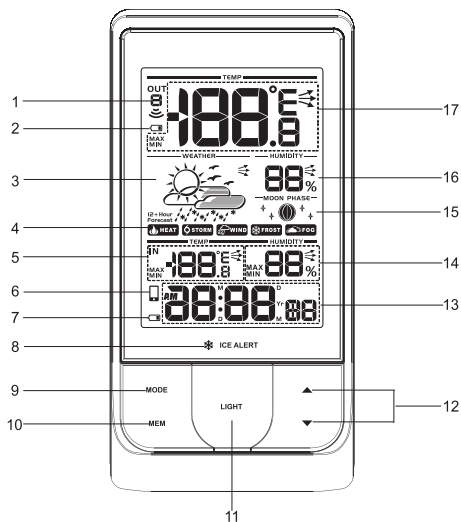

10. **MEM (MINNE)**: visa nuvarande, högsta och lägsta temperatur/luftfuktighet
11. **LIGHT (LJUS)**: aktivera bakgrundsbelysning
12. / : öka / minska inställning, endast för att välja kanaler utomhus (1-5); aktivera/deaktivera hopparring.
13. **AM/PM**: för-/eftermiddag

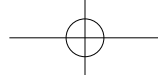

SWE

**MD/DM/Yr (MÅN/DAG/ÅR)** : kalender/klocka med veckodag (timme: minut med ny bildskärm)

14. Luftfuktigheten inomhus (aktuell/**MAX/MIN**) med luftfuktighetstrend
15. Visning av månfaser
16. Luftfuktighet utomhus (aktuell /**MAX/MIN** med luftfuktighetstrend
17. Utomhus temperatur (aktuell/**MAX/MIN**) med temperaturtrend

## BAKIFRÅN

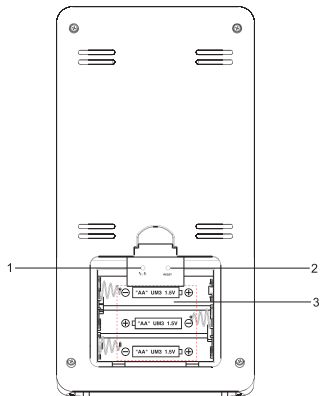

1. °C / °F: Välj temperaturenhet
2. **RESET** (ÅTERSTÄLL): Återställ enheten till standardinställningarna
3. Batterifack

## FJÄRRGIVARE

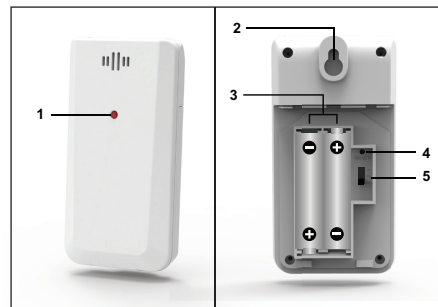

1. LED indikator
2. Väggh monteringshål
3. Batterifack
4. **RESET** knapp
5. Kanalomkopplare

**KOMMA IGÅNG****SÅTT I BATTERIER**

1. Ta bort batterifacket.
2. Sätt i batterierna, med rätt polaritet (+ / -).
3. Tryck **RESET** (ÅTERSTÄLL) efter varje batteribyte.

 <b>PLACERING</b>	<b>BETYDELSE</b>
Klocka / larm	Lågt värde huvudenhetens batterier
Utomhus temperaturområde	Lågt värde givarens batterier

**FJÄRRGIVARE**

Huvudenheten kan samla in data från upp till 5 sensorer.

**Att ställa in givaren:**

1. Öppna batterifacket.
2. Välj en kanal och tryck på **RESET** (ÅTERSTÄLL).
3. Stäng batteriluckan.
4. Placera givaren inom 30m (98 fot) avstånd från huvudenheten med hjälp av tabellen stativ eller väggfäste.

**TIPS** Perfekt plats för givaren skulle vara i någon placering på utsidan på en höjd av högst 1.5m (5 ft) och som kan skydda den från direkt solljus eller våta förhållanden för en exakt mätning.

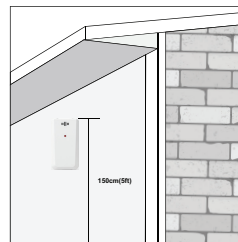



**NOTERA** Använd alkaliska batterier för längre kapacitet och vanliga litumbatterier vid en temperaturer under fryspunkten.

**SÄNDNING AV GIVARE DATA****Mätning från en givare:**

Tryck på och håll samtidigt ned **▲** och **MODE (VAL)**.

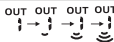
**Givaresymbolen i fjärrgivarens område visar status:**

<b>SYMBOL</b>	<b>BESKRIVNING</b>
	Huvudenheten söker efter givare.
	En kanal har hittats.
	Givaren kan inte hittas.

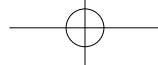

**TIPS** Räckvidden kan variera beroende på många faktorer. Du kan behöva experimentera med olika placeringar för att få bästa resultat.

## KLOCKA

### MANUELLT INSTÄLLD KLOCKA

1. Tryck på och håll ned **MODE** (VAL) .
2. Tryck på ▲ eller ▼ för att ändra inställningarna.
3. Tryck på **MODE** (VAL) för att bekräfta.
4. Inställningarna är: 12/24 timmars format, timme, minut, år, kalenderformat (dag-månad / månad-dag), månad, dag och språk.

Språken är engelska (E), tyska (D), franska (F), italienska (I), samt spanska ( S ).

### Att välja visningsläge:

Växla **MODE** (VAL) för att välja mellan klocka med sekunder / veckodag / kalender / månfas.

## VÄDERPROGNOS

Den här produkten skapar prognoser för kommande 12 timmars väder inom en radie 30-50 km (19-31 mile).

	Soligt
	Delvis molnigt

	Molnigt
	Regn
	Snö

## VÄDER VARNINGSMEDDELANDE

Vädervarningar ger indikationer på sannolika omständigheter som kan uppstå utifrån väderstationens beräkningar. Betydelseerna för varningar visas nedan:

VARNING	MEDDELANDE
<b>HEAT</b>	Risk för höga temperaturer
<b>WIND</b>	Risk för höga vindhastigheter
<b>STORM</b>	Risk för storm
<b>FOG</b>	Risk för dimma
<b>FROST</b>	Risk för is

## TEMPERATUR OCH FUKTIGHET

### Välj temperaturenhet:

- Välj °C eller °F för temperaturavläsningar med den övre delen av en penna.

### Välj en utomhus givare för avläsningar:

- Växla ▲ för att välja önskad givare.

**Automatisk sökning bland givarna:**

- Tryck på och håll ned ▼ och **MEM** (MINNE) samtidigt för att visa varje givares data under 3 sekunder.
- För att avsluta, tryck på ▲.

**Visa nuvarande och dagens högsta och lägsta registreringar från en vald givare:**

- Växla **MEM** (MINNE).
- Tryck och håll inne **MEM** (MINNE).

**ISVARNING**

Om värdet på kanal 1 givaren faller från 3°C till -2°C (37°F till 28°F), blinkar LED-indikatorn, och slutar blinka först när temperaturen är utanför detta område.

- Tryck samtidigt ▲ och ▼ för att deaktivera isvarning.

**NOTERA** Isvarning gäller endast på kanal 1, för att förhindra blinkande lysdiod, välj kanal 2 eller 3 på sensor för utomhusbruk.







**VÄDERPROGNOSER**

Symboler för temperatur, fuktighet och tryck trend är baserade på de senaste värdena.

STIGANDE	JÄMN	FALLANDE
		

**MÅNFASER**

I läget månfaser, tryck på ▲ eller ▼ för att skanna genom åren (2001 till 2099).

	Nymåne		Fullmåne
	Växande månskära		Avtagande halvmåne
	Första kvarteret		Tredje kvarteret
	Växande halvmåne		Minskande månskära

**NOTERA** Stjärnsymboler kring månens fas visas från klockan 6 på kvällen till klockan 6 nästa morgon.

**BAKGRUNDSBELYSNING**

Tryck på **LIGHT** (BELYSNING) om du vill aktivera bakgrundsbelysningen i 5 sekunder.

**ÅTERSTÄLL**

Tryck på **RESET** (ÅTERSTÄLL) för att återgå till standardinställningarna.



## ANSLUT TILL DIN MOBILA ENHET

Du kan fjärrstyra väderstationen och läsa informationen om väder via Bluetooth® 4.0 på din mobila enhet med den nedladdade applikationen från Apple Store och Google Play Store. För att snabbt hitta programmet, skriv "**Weather@Home**" som sökord i sökmotorn.

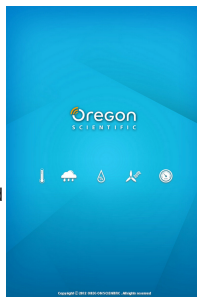

Se till att din mobiltelefon är kompatibel med iOS 8 eller Android 4,4 med Bluetooth® 4,0.

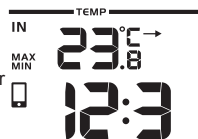

## PARA IHOP DIN VÄDERSTATION

Först av allt måste du para ihop din väderstation med din mobila enhet.  Väderstationens skärm blinkar vid hopparning och efter hopparning.

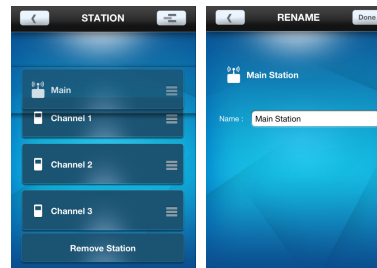

Tryck på  för att aktivera hopparning med huvudenheten under 30 sekunder.





1. Öppna appen, tryck på **Connect** (anslut). Appen kommer automatiskt att söka efter väderstationen.
2. När parningen har lyckats kommer stationen och kanalnumren att visas.
3. Tryck på varje kanal för att ändra kanalens namn. (Upp till 20 tecken, inklusive mellanslag, tillåts.) Tryck på  om du är klar. Tryck på  för att lämna skärmen.

### Ta bort givare:

För att ta bort givaren från väderstationen, klicka på **Remove Station** (Ta bort station) på skärmen: **STATION** Alla givare kommer att tas bort samtidigt.

### Flytta givarna på skärmen:

1. På bilden **STATION** trycker du på .
2. Tryck på och håll ned på höger sida av en givare. Dra den till önskad position.
3. Tryck på  för att bekräfta.



### INSTÄLLNINGAR



Du kan ställa in din väderstation med programmet, t.ex. måttenheter.

#### Inställningarna är följande:

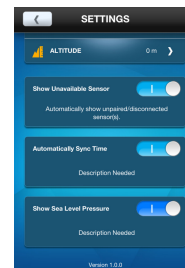
- Temperatur
- Lufttryck
- Nederbörd (inte tillgänglig i BAR218HGX)
- Vindhastighet (inte tillgänglig i BAR218HGX)
- Höjd
- Visa ej tillgängliga givare
- Automatiskt synkroniserad tid
- Visa tryck vid havet



#### Välj måttenhet:

1. Tryck på  för att visa måttenhet.
2. Välj önskad enhet.
3. Tryck på  för att gå tillbaka till föregående skärmsida.

#### Ställ in höjd:

Höjden motsvarar höjd över havet för din position.

1. Fyll in huvudenhetens höjd i den tomma rutan.
2. Tryck på **Done** (Klar).



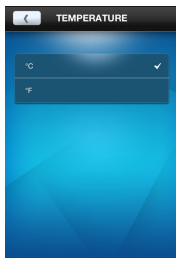
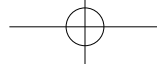

## VISA AKTUELLA MÄTNINGAR

Du kan genom programmet direkt visa alla mätvärden från olika sensorer. Avläsningarna finns på skärmen **HOME** (HEM).

**NOTERA** Om ikonen för låg batterinivå  visas på skärmen, byt ut batterierna för motsvarande enhet.

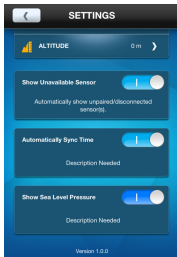

## För att visa tillgängliga givare:

Om givaren är utanför området, är värdena avbrutna och — (bindestreck) visas på skärmen. Om du inte vill visa de ej tillgängliga givarna:

- Tryck på skärmen **SETTINGS** (INSTÄLLNING) tryck på och skjut knappen till höger för att slå på funktionen, eller skjut åt vänster för att stänga av den.

## Synkronisera automatiskt tid:

Tid och datum för din väderstation kan synkroniseras automatiskt med din mobila enhet.

- Tryck på skärmen **SETTINGS** (INSTÄLLNING) tryck på och skjut knappen till höger för att slå på funktionen, eller skjut åt vänster för att stänga av den.

## Visa trycket vid havet:

Efter att höjd över havet är inmatad, kan du se lufttryck vid havet på skärmen **HOME** (HEM).



- Tryck på skärmen **SETTINGS** (INSTÄLLNING) tryck på och skjut knappen till höger för att slå på funktionen, eller skjut åt vänster för att stänga av den.

**NOTERA** När höjden över havet är 0 meter, är trycket vid havet det lokala trycket. Om höjden ställs in till den aktuella platsen, visas det nya trycket som ett lufttryck vid havsytan.

## VISA AVLÄSNINGSHISTORIK

Du kan visa historiken genom programmet. Historiken kan även presenteras i diagram (tidigare 24 timmar eller senaste 7 dagarna).

### Visa historik:

1. Klicka på önskad givare-område på skärmen.
2. Tryck    för att välja önskad data eller tryck på  för att sortera data efter datum.



## FÖRSIKTIGHETSÅTGÄRDER

- Använd endast nya batterier av rätt typ och storlek. Blanda inte nya och gamla batterier, eller olika typer av batterier.
- Gör dig inte av med gamla batterier genom att

blanda dem med kommunalt osorterat avfall. Det är nödvändigt att sortera gamla batterier separat.

- Om du inte planerar att använda din produkten på ett tag, avlägsna batterierna. Batterier kan läcka kemikalier som kan skada elektroniska delar.
- Utsätt inte apparaten för kraftigt våld, stötar, damm, extrema temperaturer eller fukt.
- Utsätt inte produkten för vatten. Om du spiller vätska över den, torka omedelbart med en mjuk, luddfri trasa.
- Rengör inte apparaten med frätande eller slipande material.
- Mixtra inte med enhetens interna komponenter då detta kan påverka garantin.
- Av trycktekniska skäl, kan displaybilderna i denna manual skilja sig från dem i verkligheten.
- Förbrukad produkt måste sorteras som specialavfall på avsedd miljöstation och får inte slängas som vanligt restavfall.
- Innehållet i denna manual får ej kopieras utan tillverkarens medgivande.

**NOTERA** De tekniska specifikationerna för denna produkt och innehållet i användarmanualen kan komma att ändras utan vidare upplysning.

**NOTERA** Egenskaper och tillbehör kan skilja mellan olika länder. För mer information, kontakta ditt lokala inköpsställe. För att ladda ner en elektronisk version av manualen, vänligen besök <http://global.oregonscientific.com/customerSupport.php>.

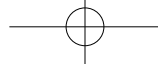

## SPECIFIKATIONER

TYP	BESKRIVNING
<b>HUVUDENHET</b>	
L x B x H	7,32 x 3,7 x 2,13 in (186 x 94 x 54 mm)
Vikt	223 g (7,87ounces) utan batteri
Temperaturområde	-5 °C till 50 °C (23 °F till 122 °F)
Signalfrekvens	433 MHz
Område för luftfuktighet	25% - 95%
Ström	3 X UM-3 (AA) 1,5V batterier
Temperaturområde för isvarning	3 °C till -2 °C

## FJÄRRENHET (THGR511)

L x B x H	96 x 50 x 22 mm (3,78 x 1,97 x 0,87 tum)
Vikt	49 g (1,7 oz)
Överföringsavstånd	30m fri sikt
Temperaturområde	-20°C till 60°C (-4°F till 140°F)
Drift	2 x UM-4 (AAA) 1,5 V batterier

## OM OREGON SCIENTIFIC

Besök vår webbsajt [www.oregonscientific.se](http://www.oregonscientific.se) för att ta reda på mer om Oregon Scientifics produkter.

Om du har några frågor är du välkommen att kontakta vår Kundtjänst på [info@oregonscientific.se](mailto:info@oregonscientific.se).

Oregon Scientific Global Distribution Limited reserverar sig rätten att redigera och uttolka innehåll, terminologi och föreskrifter i denna manual samt att göra tillägg när som helst utan föregående meddelande. Om skillnader finns mellan den engelska versionen och andra språkversioner, gäller den engelska.

## EU-FÖRSÄKRAN OM ÖVERENSSTÄMMELSE

Härmed deklarerar tillverkaren Oregon Scientific Global Distribution Limited att radioutrustning typ Weather@Home Bluetooth-aktiverad väderstation (Modell: BAR218HGX) Står i överensstämmelse med 2014/53/EU-direktiv. Står i överensstämmelse med 2014/53/EU-direktiv. Den fullständiga texten av EU-försäkran om överensstämmelse finns tillgänglig på följande Internetadress:

<http://global.oregonscientific.com/customerSupport.php>



## LÄNDER SOM OMFATTAS AV RED-DIREKTIVET

Alla länder inom EU, Schweiz 

och Norge 

## INFORMATION TILL ALLA ANVÄNDARE



I enlighet med de europeiska direktiven 2011/65/ EU och 2012/19/EU, som hänsyftar till användning av farliga substanser i elektrisk och elektronisk apparatur liksom avyttring av avfall.

Symbolen med den överkryssade soptunnan som finns på apparaten, anger att produkten måste samlas upp och avyttras separat i förhållande till annat avfall när den fullgjort sin livstid.

Användaren måste därför överlämna den utslitna apparaturen till lämpliga uppsamlingsställen för sorterat elektroniskt och elektrotekniskt avfall eller lämna tillbaka den till återförsäljaren på samma gång som han/hon köper en ny likvärdig apparat, enligt principen en gammal produkt i utbyte mot en ny. Lämplig sortering

av den nedskrotade apparaturens olika delar för därpå följande återvinning, behandling och miljövänlig sanering bidrar till att undvika förorening av miljön och negativa effekter på hälsan, liksom att det gynnar återanvändning av de material som apparaturen är gjord av.

Om användaren nedskrotar produkten felaktigt medför det att sanktioner enligt gällande lagstiftning kommer att tillämpas.

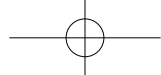

Weather@Home  
 家用天氣預報  
 藍牙天氣儀  
 型號: BAR218HGX  
 使用手冊

**目錄**

簡介----- 2

概觀----- 2

  正面----- 2

  背面----- 3

遙控感應器----- 3

使用入門----- 4

  放置電池----- 4

  遙控感應器----- 4

  感應器數據輸送----- 4

時鐘----- 5

  手動設定時鐘----- 5

天氣預報----- 5

天氣預警提示----- 5

溫度和濕度----- 6

霜凍預警----- 6

天氣趨勢----- 6

月相----- 6

背景燈光----- 6

重置----- 7

連接到智能電話----- 7

  配對你的天氣儀----- 7

  設定----- 8

  檢視即時顯示----- 9

  檢視歷史數記錄----- 10

技術規格----- 10

關於歐西亞----- 11

## 簡介

感謝您選擇我們Oregon Scientific™的家用天氣預報藍牙天氣儀。此外，還進行室內和室外溫度之間的變化顯示。

**註** 使用新產品時，應把本說明書放在附近以便隨時參考。使用指南內含實用的操作說明，以及技術規格和警告需知。

## 概觀

### 正面

- 遙控感應接收顯示和室外頻道選項
-  室外遙控感應電力不足
-  未來12小時天氣預報和氣壓趨勢
-  天氣預警提示
- 室內溫度顯示(即時/最高/最低)和溫度趨勢
-  智能電話連接顯示
-  主機電力不足
- 霜凍警告顯示
- MODE** (模式): 變更設置/顯示

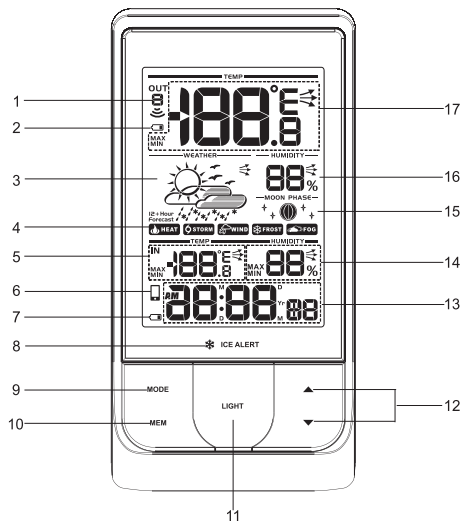

- MEM** (記憶體): 查看即時、最高和最低溫度/濕度
- LIGHT** (燈光): 啟動背景燈光
- ▲ / ▼: 提高/降低設置數值;限雙向開關 ▲ 選擇室外頻道按鈕 (1-5); 啟動/關閉相應模式
- AM/PM** (上午/下午): 上午/下午

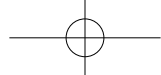

MD/DM/Yr(月日/日月/年): 日曆/時鐘和星期  
(時分秒顯示)

14. 室內濕度顯示 (即時/最高/最低)和濕度趨勢
15. 月相顯示
16. 室外濕度(即時/最高/最低) 和濕度趨勢
17. 室外溫度(即時/最高/最低) 和溫度趨勢

背面

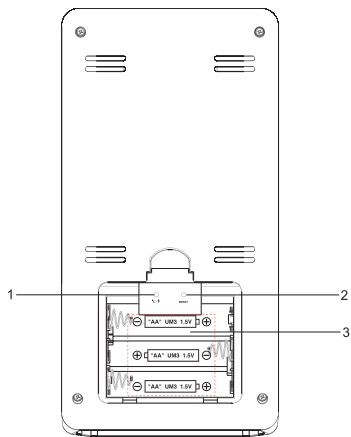

1. °C / °F: 溫度單位選項
2. **RESET** (重置): 重置原始設定電池格
3. 電池槽

### 遙控感應器

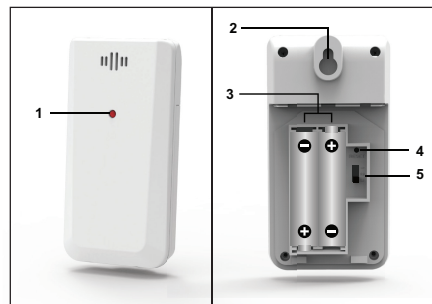

1. LED 狀態指示燈
2. 掛牆孔
3. 電池槽
4. **RESET** 重置孔
5. **CHANNEL** (頻道)切換

## 使用入門

### 放置電池

1. 移除電池蓋
2. 按正負極標誌放入電池
3. 於每次更換電池後按 **RESET** (重置)

 顯示位置	含義
時鐘/鬧鐘位置	主機電力不足
室外溫度位置	感應器電力不足

### 遙控感應器

主機最多能從5個感應器接收數據。

設置感應器：

1. 打開電池蓋子
2. 選擇頻道後按 **RESET**(重置)。
3. 合上電池蓋子。
4. 用桌架或掛牆裝置將感應器安裝距主機98尺(30米)範圍以內。

**秘訣** 最理想的安裝位置是把感應器安裝在室外，高度不超過5尺(1.5米)，且免受陽光直接照射或潮濕狀態影响的地方，有助提高讀數的準確度。

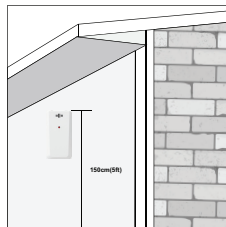

**註** 使用鹼性電池能延長電池壽命和在零度以下使用鋰電池。

### 感應器數據輸送

尋找感應器：

同時按住 **▲** 和 **MODE** (模式)

搖控感應器上的感應接收標誌顯示狀態：

 標誌	描述
	主機搜尋感應器
	頻道已找到
	搜尋不到頻道



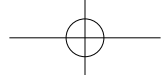

**秘訣** 傳送範圍會受各種因素影響而異，你或需要嘗試多個位置來得到最佳效果。

## 時鐘

### 手動設定時鐘

欲手動設定時鐘：

1. 按住 **MODE** (模式)
2. 按 **▲** 或 **▼** 更改設定
3. 按 **MODE** (模式) 確定
4. 設置順序：**12/24**小時制，時、分、年，日曆格式(日期-月份 / 月份-日期)，月、日與語言。

語言選擇：英文(**E**)，德文(**D**)，法文(**F**)和西班牙文(**S**)

選擇顯示模式：

選擇 **MODE** (模式) 切換時鐘的秒/星期/日曆/月相。





## 天氣預報

這產品可以預報半徑**19-31**英哩(**30-50**公里) 範圍裡未來**12**小時天氣。

	晴天
	部份有雲
	多雲
	有雨
	有雪

## 天氣預警提示

天氣預警提示提供顯示可能的的情況下，可能會出現根據氣象站的預測。預警提示的含義如下：

預警	提示
 <b>HEAT</b>	可能高溫
 <b>WIND</b>	可能大風
 <b>STORM</b>	風暴風險
 <b>FOG</b>	可能有霧
 <b>FROST</b>	可能結冰

## 溫度和濕度

### 選擇溫度單位：

- 使用針或筆尖點擊溫度標誌以選擇°C 或 °F

### 選擇室外感應器顯示：

- 切換 ▲ 選擇所需感應器顯示

### 自動掃描感應器：

- 同時按住 ▼ 和 MEM (記憶體) 3秒以顯示每個感應器數據。
- 結束按 ▲。

### 從感應器顯示一天即時、最低和最高記錄：

- 切換 MEM。

### 清除記錄：

- 按住 MEM (記憶體)。

### 欲清除記錄：

- 按住 MEM (記憶)。

## 霜凍預警

如果頻道1感應器由37°F降到28°F (3°C-2°C)，LED指示燈將閃動，並且一旦溫度超出此範圍將停止閃動。

- 同時按下 ▲ 和 ▼ 以關閉霜凍預警提示。

註 由於霜凍警報只適用於頻道1，要防止LED閃動，選擇室外感應器頻道2或3。









## 天氣趨勢

溫度、濕度和氣壓趨勢標示是根據最近的感應器顯示。

上升 ↗	穩定 →	下降 ↘
---------	---------	---------

## 月相

在月相模式，按 ▲ 或 ▼ 以掃描年份(2001至2099)。

	新月		滿月
	娥眉月		虧凸月
	上弦月		下弦月
	盈凸月		殘月

註 星形標示將從下午6點到第二天早上6點顯示。

## 背景燈光

按 LIGHT(燈光) 5秒啓動背景燈光。



## 重置

按 **RESET** 重置原始設定。

## 連接到智能電話

你可以從Apple Store下載應用程式，通過智能電話的藍牙4.0遙控設置天氣儀和閱讀天氣資訊。

為了迅速找到應用程序，在搜索引擎中輸入“**Weather@Home**”為關鍵字。

確保你的移動設備是兼容iOS 8或Android 4.4的藍牙4.0。



## 配對你的天氣儀

首先，你需要將你的天氣儀與移動設備配對。當進行配對時，會在天氣儀的屏幕上閃動，配對成功後將停留顯示在屏幕上。

按住 **▲** 30秒啓動主機配對組合。

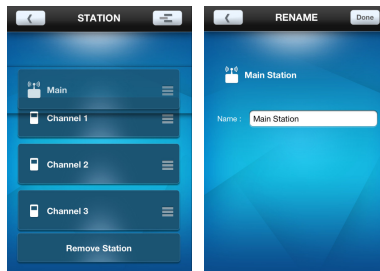
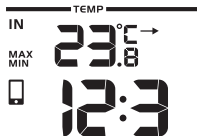



1. 打開App, 點擊**Connect**。應用程式將自動搜索氣象站。
2. 配對成功後，主機和頻道資料將顯示。
3. 輕觸各頻道可為其重新命名（包括空格在內，可多達20個字符）。輕觸 **Done** 完成。輕觸  退出。

## 刪除氣象站:

在**STATION** 屏幕上，點擊**Remove Station**刪除氣象站，氣象站將解除配對，其資料將從應用中刪除。

重新設定感應器在屏幕上的位置：

1. 在 **STATION** (天氣儀) 畫面，按 。
2. 在感應器右面按住 ，把感應器拖到所需位置。
3. 按  確認。



## 設定

您可以通過程式設置天氣儀，如測量單位。



你可以設定以下：

- 溫度
- 氣壓
- 降雨 (不適用於 BAR218HGX)
- 風速 (不適用於 BAR218HGX)
- 海拔高度
- 顯示不可用感應器

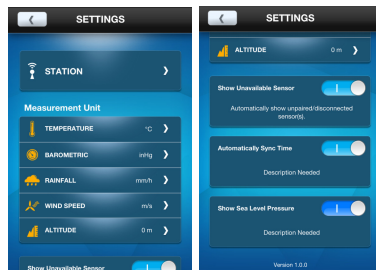
- 自動同步時間
- 顯示海面氣壓



選擇測量單位：

1. 按  檢視測量單位選項。
2. 點擊所需單位。
3. 按  回到上一個畫面。

設定海拔高度：

海拔高度反映你身處的位置從海面的距離。

1. 在主機空白的位置輸入海拔高度
2. 按 **Done** (完成)。

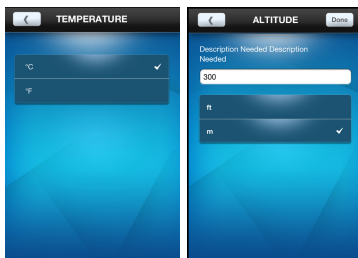
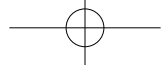

### 檢視即時顯示

您可以通過程式直接查看來自不同感應器的天氣訊息。這些訊息顯示在 **HOME** (主畫面)。

**註** 若電力不足標誌  在畫面上出現，請在相應儀器上更換電池。



### 顯示不可用感應器:

如果感應器超出範圍，數據將中斷和 — 標誌 (破折號模式) 會在屏幕上顯示。如果你不想顯示不可用的傳感器:

- 在 **SETTINGS** (設定) 畫面，點擊和向右拖曳啟動功能，或向左拖曳將其關閉。

### 自動同步時間:

天氣儀上的時間和日期可以與你的移動設備自動同步。

- 在 **SETTINGS** (設定) 畫面上，點擊和向右拖曳啟動功能，或向左拖曳將其關閉。

### 顯示海面氣壓:

輸入海拔高度數據後，你可以在 **HOME** 主畫面查看海面氣壓。

- 在 **SETTINGS** (設定) 畫面上，點擊和向右拖曳啟動功能，或向左拖曳將其關閉。

**註** 當海拔高度設定為0米時，氣壓顯示為當地氣壓。如果海拔高度被設置到當前位置，新的氣壓顯示將為海面氣壓。

## 檢視歷史數據記錄

您可以通過程序查看歷史數據記錄。歷史數據也可以圖表顯示 (過去24小時或過去7天)。



## 查看歷史數據記錄

1. 在畫面上點擊所需感應器位置。
2. 按 選擇所需數據或點擊按 日期排列數。



## 注意事項

- 不得對機體猛力施壓、撞擊、或放在溫差大或過於濕度的地方。
- 不得利用類似報紙、窗簾等物品蓋住產品的通風口。
- 請勿將機體浸水若不慎將機體沾水，立即使用柔軟、不含麻的布將之擦拭。
- 不得使用磨損或腐蝕性的物質清潔機體。
- 不得以硬物刮液晶體顯示屏，此舉可能導致顯示屏的損壞。
- 不要干擾機體的內部零件。此舉將使保證失效。
- 必須使用新電池。請勿混合使用新舊電池。
- 本指南所示圖像也許與實物不同。
- 棄置本產品時，確認已個別將之回收。
- 把產品放在某些木材表面可能會損壞其塗層。我們對此等損壞概不負責。請諮詢傢具製造商，了解保養傢具的資訊。
- 未經製造商的許可，不可複製手冊中的任何內容。
- 丟棄舊電池時，不得視之為不必分類的都市廢棄物。必須以特別方式另行處理此等廢棄物。
- 請注意，部份機體配備電池安全繫帶。首次使用前，請將之從電池格中拆下。



**註** 我們有權更改本產品的技術規格和本使用指南之內容，而無需另行通知。

### 技術規格

種類	說明
<b>主機</b>	
L x W x H 長x闊x高	186 x 94 x 54 毫米 (7.32 x 3.7 x 2.13 吋)
重量	223克(7.87安士) 不包括電池
溫度範圍	-5°C to 50°C (23°F to 122°F)
信號頻率	433 MHz 頻率
濕度範圍	25% - 95%
電量	3 x UM-3 (AA) 1.5V 電池
冰點提示溫度範圍	3°C to -2°C
<b>遙控裝置(THGN132N)</b>	
L x W x H 長x闊x高	96 x 50 x 22 毫米 (3.78 x 1.97 x 0.87吋)
重量	49克(1.7安士) 不包括電池
輸送範圍	98尺(30米) 無中斷

溫度範圍	-20°C to 60°C (-4°F to 140°F)
電量	2 x UM-4 (AAA) 1.5 V 電池

### 關於歐西亞

瀏覽我們的網站[www.oregonscientific.com.hk](http://www.oregonscientific.com.hk)瞭解更多關於歐西亞的產品。

如有任何疑問，請聯絡我們的客戶服務  
[enquiry@oregonscientific.com.hk](mailto:enquiry@oregonscientific.com.hk)。

Oregon Scientific Global Distribution Limited。保留權利，隨時行使獨立裁決權，於未事前通知情況下詮釋和解釋本用戶手冊之任何內容、條款與條件並修改之。若英語版本與任何其他語言版本有任何不一致處，將以英語版本為準。



©2019 Oregon Scientific. 版權所有。





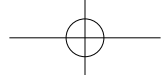

简中

Weather@Home  
 蓝牙功能气象站  
 型号: BAR218HGX  
 用户手册

**目录**

简介-----2

概要-----2

  正面图-----2

  背面图-----3

  传感器 (THGR511) -----3

开始操作-----4

  插入电池-----4

  遥控器-----4

  传感器数据传输-----4

闹钟-----5

  手动设置闹钟-----5

天气预报-----5

天气警报信息-----5

温度和湿度-----6

冰冻警报-----6

天气趋势-----6

月相-----6

背光灯-----6

重置-----7

与您的手机连接-----7

  配对您的气象站-----7

  设置-----8

  查看当前读数-----9

  查看历史读数-----10

注意事项-----10

技术参数-----11

关于欧西亚-----11









## 简介

感谢您选择我们Oregon Scientific™的Weather@Home蓝牙功能气象站。此外，还进行室内和室外温度之间的变化显示。

**注** 使用新产品时，应把本手册放在附近以便随时参考，其中内含实用操作说明，以及技术规格和警告告知。

## 概要

### 正面图

1. 遥控器接收指示器和已选择的户外频道
2.  户外传感器电池低
3. **12+Hour Forecast**: 未来12小时的天气预报和气压变化趋势
4.  **HEAT** /  **STORM** /  **WIND** /  **FROST** /  **FOG**: 天气警报消息
5. 室内温度及温度变化趋势读数 (当前/最高/最低)
6.  BLE连接指示器
7.  主机电池低
8. 结冰警报LED指示器
9. **MODE** (模式): 改变设置/显示
10. **MEM** (存储): 查看当前最高和最低温度/湿度

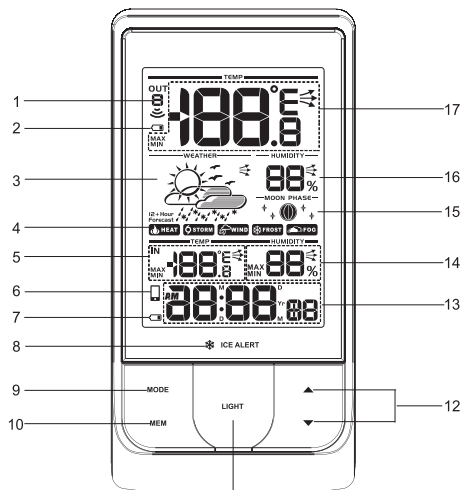

11. **LIGHT** (灯): 打开背光灯
12. **▲/▼**: 设置值的增加/减小值; 仅拨动 **▲** 按键以选择户外频道(1-5); 打开/关闭配对模式。
13. **AM/PM**: 上午/下午

**MD/DM/Yr** (月日/日月/年): 带工作日的日历/闹钟 (小时:分钟,带秒种显示)

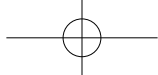

14. 室内湿度及湿度变化趋势读数(当前/最高/最低)
15. 月相显示
16. 室外湿度及湿度变化趋势读数(当前/最高/最低)
17. 室外温度及温度变化趋势读数(当前/最高/最低)

背面图

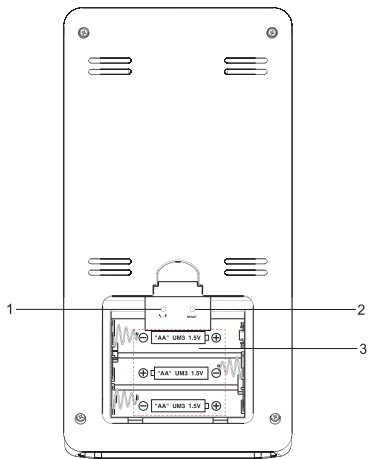

1. °C / °F: 选择温度单位
2. **RESET** (重置):重置默认设置的单位
3. 电池盒

传感器 ( THGR511 )

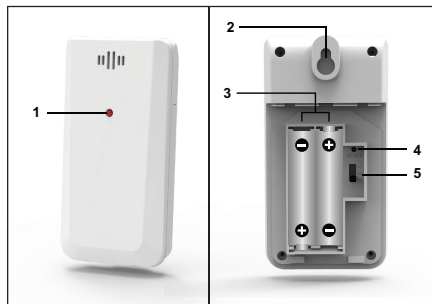

1. 状态指示器
2. 墙安装孔
3. 电池盒
4. **RESET** (重置): 重置孔
5. **CHANNEL** (频道): 频道开关

## 开始操作

### 插入电池

1. 移开电池盒。
2. 插入电池，匹配极性 (+/-)。
3. 每个电池变化后，按下**RESET** (重置)

 位置	说明
闹钟/报警区域	主机电池低
室外温度区域	传感器电池低

### 遥控器

主机可至少从5个传感器收集数据。

#### 设置传感器：

1. 打开电池盒。
2. 选择一个频道，然后按下**RESET** (重置)。
3. 关闭电池盖。
4. 使用座台脚或墙安装将传感器置于主机的98 尺 (30米) 内。

**提示** 传感器的理想位置为不高于5尺 (1.5米) 的住宅外部的任何位置，可保护其不受阳光直射或潮湿环境，以确保精确读数。

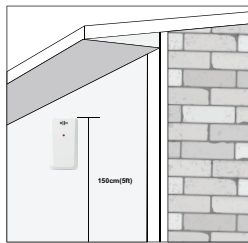





**注** 为了使用时间更长，使用碱性电池，温度在零度以下使用消费级锂电池。

### 传感器数据传输

#### 如需搜索传感器：

同时按住 **▲** 和 **MODE** (模式) 按键。

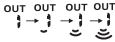
#### 遥控器区域的传感器接收图标显示状态：

 图标	说明
	主机正在搜索传感器。
	已找到一个频道。
	不能找到传感器。

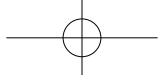

**提示** 由于许多因素，传输范围可能不同。您需要在不同位置实验，以得到最佳结果。

## 闹钟

### 手动设置闹钟



1. 按住**MODE** (模式) 按键。
2. 按下 ▲ 或 ▼，改变设置。
3. 按下**MODE** (模式) 按键进行确认。
4. 设置顺序为：12/24小时格式，小时，分钟，年。日历格式(日-月/月-日)，月，日和语言。语言选项为英语 (**E**)，德语 (**D**)，法语 (**F**)，意大利语 (**I**)和西班牙语 (**S**)。

### 选择显示模式：

拨动**MODE** (模式) 按键，在带秒/工作日/日历/月相的闹钟中进行选择。

## 天气预报

该产品预报在未来12小时内19-31英里 (30-50 km) 半径范围内的天气。

	晴
	局部多云
	多云
	雨
	雪

## 天气警报信息

天气警报信息提供基于气象站计算的可能发生的天气情况指示。

警报	信息
 <b>HEAT</b>	高温风险
 <b>WIND</b>	大风风险
 <b>STORM</b>	暴雨风险
 <b>FOG</b>	大雾风险
 <b>FROST</b>	冰冻风险

## 温度和湿度

### 选择温度单位:

- 使用别针或笔尖选择°C或°F作为温度读数。

### 选择室外传感器读数:

- 拨动▲, 以选择您所需的传感器读数。

### 在传感器中自动扫描:

- 同时按住▼和MEM(存储)按键以显示每个传感器的数据, 持续时间为3秒。
- 如需结束, 按下▲。

### 从已选择的传感器显示当前、最小和最大记录:

- 拨动MEM(存储)按键。

### 清除记录:

- 按住MEM(存储)按键。

## 冰冻警报

如果频道1传感器的温度从37°F跌至28°F (3°C至-2°C), LED指示器闪烁, 当温度不在该范围时, 停止闪烁。

- 同时按下▲和▼以终止冰冻警报。

**注** 由于冰冻警报仅适用于频道1, 为避免LED闪烁, 选择室外传感器的频道2或频道3。









## 天气趋势

温度、湿度和气压变化趋势图标都是基于近期的传感器读数。

升高	平稳	下降
		

## 月相

在月相模式, 按下▲和▼可对这些年进行扫描(2001-2099)。

	新月		满月
	娥眉月		亏凸月
	上弦月		下弦月
	盈凸月		残月

**注** 月相周围的星标从晚上6:00显示至第二天早上6:00。

## 背光灯

按下LIGHT(灯)按键, 打开背景灯, 持续5秒。

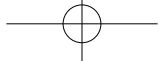

## 重置

按下**RESET** (重置) 按键, 返回至默认设置。

## 与您的手机连接

您可远程设置气象站, 使用从苹果商城下载的应用以及您的手机设备, 通过蓝牙4.0读取天气信息。为了迅速找到应用, 在搜索引擎中输入关键字“**Weather@Home**”。

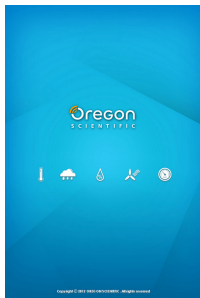

确认您的手机系统为配备蓝牙4.0的iOS8或Android4.4。

## 配对您的气象站

首先, 您需要将气象站与您的手机配对。配对时, 在手机在气象站屏幕上闪烁, 成功配对后, 保持灯亮。

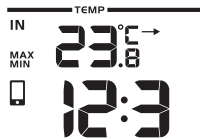

按下 **▲**, 以确认主机的配对, 时间持续**30秒**。

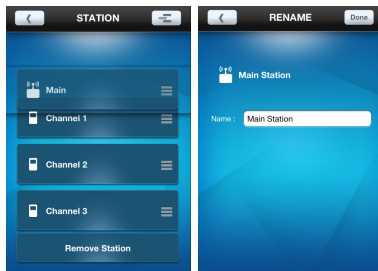



1. 打开App, 点击**Connect**。应用程序将自动搜索气象站。
2. 配对成功后, 主机和频道数据将显示。
3. 轻触各频道可为其重新命名 (包括空格在内, 可多达20个字符)。轻触 **Done** 完成。 **<** 退出。

## 删除气象站:

在**STATION** 屏幕上, 点击**Remove Station**删除气象站, 气象站将解除配对, 其数据将从应用中删除。

## 重新定位屏幕上的传感器

1. 在 **STATION** (气象站) 屏幕, 轻触 。
2. 按住传感器右侧的 。拖动至您所需的位置。
3. 轻触 , 进行确认。

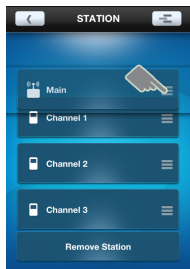

- 海拔
- 显示不可用传感器
- 自动同步时间
- 显示海平面气压

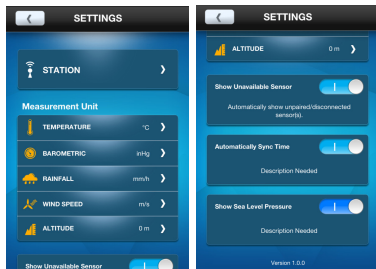



## 设置

可通过应用设置您的气象站, 如测量单位。

### 设置如下:

- 温度
- 气压
- 降雨 (在BAR218HGX不可用)
- 风速 (在BAR218HGX不可用)

### 选择测量单位:

1. 轻触 , 以查看测量单位选项。
2. 轻触您所需的单位。
3. 轻触  返回至上一屏幕。

### 设置海拔:

海拔反映了您所处位置海平面的距离。

1. 在空格中填写您的主机海拔。
2. 轻触 **Done** (完成)。



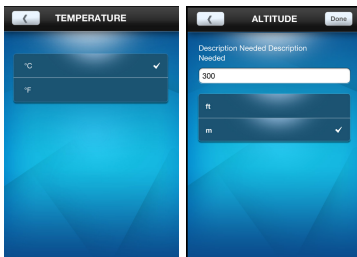
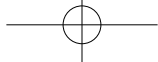

### 查看当前读数

可通过应用一次直接查看不同传感器的所有天气读数。读数在**HOME** (主屏幕)。

**注**：如果屏幕出现电池图标，请更换相应设备的电池。



### 显示不可用传感器：

如果传感器不在范围内，读数被干扰并且屏幕上出现 — (破折号模式)。如果不想显示不可用的传感器：

- 在**SETTINGS** (设置) 屏幕，触摸和滑动按钮至右侧打开功能，或滑动至左侧关闭功能。

### 自动同步时间：

移动设备可自动同步气象站的时间和日期。

在**SETTINGS** (设置) 屏幕，触摸和滑动按钮至右侧打开功能，或滑动至左侧关闭功能。

### 显示海平面气压：

输入海拔后，可在**HOME** (主屏幕)，查看海平面气压。

- 在**SETTINGS** (设置) 屏幕，触摸和滑动按钮至右侧打开功能，或滑动至左侧关闭功能。





**注** 当海拔设置为0米时，气压读数为局部气压。如果海拔设置至当前位置，显示的新气压读数将作为海平面气压。

## 查看历史读数

可通过应用查看历史数据。历史读数也可通过表盘显示 (过去24小时或过去7天)。



## 查看历史:

1. 轻触屏幕上所需的传感器区域。
2. 轻触   ，以选择所需数据或轻触 ，根据日期对数据进行分类。



## 注意事项

- 不得对机体猛力施压、撞击、或放在温差过大或过于潮湿的地方。
- 不得用报纸、窗帘等物品盖住产品的通风口。
- 请勿将机体浸水。若机体不慎沾水，请立即使用无绒软布擦拭干净。
- 不得使用磨损或腐蚀性物质清洁机体。
- 请勿使用硬物刮擦液晶显示屏，以免损坏显示屏。
- 不要干扰机体内部零件，以免使保修失效。
- 必须使用新电池。请勿混合使用新旧电池。
- 本手册所示图像可能与实物有所不同。
- 弃置本产品时，确保妥当回收以备处置。
- 把产品放在某些木材表面可能会损坏其涂层，对此类损坏我们恕不负责。请咨询家具制造商，了解有关家具保养的详细信息。
- 未经制造商许可，不可复制本手册中的任何内容。
- 丢弃旧电池时，不得将其视为不可分类废弃物，而必须以特别方式另行处理。
- 请注意，部份机体配备电池安全带。首次使用前，请将其从电池格中拆下。

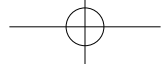

**注** 我们保留权限随时变更本产品的技术规格和本使用手册内容，恕不另行通知。请访问 <http://global.oregonscientific.com/customerSupport.php> 下载电子版的用户手册。

### 技术参数

类型	说明
<b>主机</b>	
L x W x H 长 x 宽 x 高	186 x 94 x 54 毫米 (7.32 x 3.7 x 2.13英寸)
重量	223 克 (7.87 盎司) 不包括电池
温度范围	-5°C 至 50°C (23°F 至 122°F)
信号频率	433 MHz
湿度范围	25% - 95%
功率	3 x UM-3 (AA) 1.5V 电池
冰点提醒温度范围	3°C to -2°C
<b>远程装置 (THGR511)</b>	
L x W x H 长 x 宽 x 高	96 x 50 x 22 毫米 (3.78 x 1.97 x 0.87英寸)
重量	49克 (1.7盎司) 不包括电池

传输范围	98尺(30米) 无障碍
温度范围	-20°C 至 60°C (-4°F至140°F)
功率	2 x UM-4 (AAA) 1.5 V 电池

### 关于欧西亚

浏览我们的网站[www.oregonscientific.com.cn](http://www.oregonscientific.com.cn)了解更多关于欧西亚的产品。

如有任何疑问，请联络我们的客户服务  
[enquiry@oregonscientific.com.cn](mailto:enquiry@oregonscientific.com.cn)。

Oregon Scientific Global Distribution Limited保留权利，随时行使独立裁决权，于未事前通知情况下诠释和解释本用户手册之任何内容、条款与条件并修改之。若英语版本与任何其他语言版本有任何不一致处，将以英语版本为准。

**Oregon**  
S C I E N T I F I C  
歐 西 亞  
[www.oregonscientific.com](http://www.oregonscientific.com)  
Oregon Scientific Inc.  
Tualatin, Oregon USA  
欧西亚中国授权制造商  
展科电子(深圳)有限公司  
制造地:中国深圳宝安臣田工业村



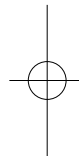
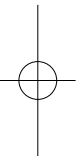

© 2019 Oregon Scientific. All rights reserved.

P/N:300103545-00012-10

