

REGULATORS OCTOPUS MV

WARNING

CAREFULLY READ THIS INSTRUCTION MANUAL BEFORE USE, AND KEEP IT FOR FUTURE REFERENCE.

INTRODUCTION

Congratulations on your purchase of a Mares regulator. This product is part of Mares's new family of advanced high performance underwater life support system. It is designed, manufactured and tested by experienced divers.

For over 40 years, Mares has been an industry leader in dive innovation and technology. The modular of regulators have several key features for your diving comfort.

Important:

Any critical information or warnings that might affect the performance or result in the injury or death of the technician, regulator owner, or other persons is highlighted with the following symbols:

DANGER

Indicates an imminently hazardous situation which, if not avoided, will result in death or serious injury.

WARNING

Indicates a potentially hazardous situation which, if not avoided, could result in death or serious injury.

CAUTION

Indicates a potentially hazardous situation which, if not avoided, may result in minor or moderate injury. It may also be used to alert against unsafe practices.

MARES reserves the right to modify any products, processes and manufacturing techniques at any time. It is the technicians' responsibility to acquire the latest information and parts from MARES for service and repairs to be performed.

IMPORTANT:

If the instructions provided in the manual are unclear or difficult to understand, please contact MARES before using the regulator or attempting any repairs.

WARNING

Carefully follow these and all the other instructions concerning your MARES regulator and all other SCUBA equipment. Failure to do so could lead to serious injury or death.

WARNING

As with all SCUBA equipment, MARES regulators are designed to be used by trained, certified divers only. Failure to fully understand the risks of using such equipment may result in serious injury or death. DO NOT use this regulator or any SCUBA equipment unless you are a trained, certified MARES diver.

EC CERTIFICATION

The MARES regulators described in this manual have been tested and certified by Registered Test Centre No. 0426 - Italcert - Viale Sarca 336, Milano - I, in compliance with EC directive 89/686/EEC of 21 December 1989. The test procedures were conducted according to the EN 250: 2000 standard, in conformance with the aforesaid directive which sets out the conditions for marketing and essential safety requirements for Category III Personal Protective Equipment (PPE).

The certification testing results are the following:

Model	Warm water (Temp. = > 10°C)	Cold Water (Temp. < 10°C)	Marking	Position
Octopus MV	approved	approved	CE 0426	on the hose

The CE0426 marking for Octopus MV is an adhesive label affixed to the hose. This label must not be removed.

The CE markings indicate that the product is compliant with the essential health and safety requirements (Att. II DE 89/686/CEE). The suffix 0426 after the letters "CE" indicates the Italcert Registered Test Center in charge of monitoring the production under Art. 11B DE 89/686/EEC.

REFERENCES TO EN 250: 2000 – OBJECT – DEFINITIONS – LIMITS

Object: The requirements and tests provided for in EN 250: 2000 are aimed at providing a minimum safety level for the operating of diving breathing apparatuses at a maximum depth of 50m/162 feet.

Scuba – Definition: Self-contained, open-circuit compressed air underwater breathing apparatus, equipped with an air cylinder

Scuba – Minimum equipment (EN 250: 2000):

- Air cylinder / cylinders.
- Regulator.
- Safety device, e.g. pressure gauge / computer or reserve or alarm.
- Carrying frame or holding device, e.g. backpack and/or strap.
- Facepiece (mouthpiece assembly or full face mask or diving helmet).
- Operating instructions.

WARNING

SCUBA equipment complying with EN 250 is not intended for breathing by more than one user at the same time.

WARNING

If SCUBA equipment is configured and used by more than one diver at the same time, the cold water and breathing performance may not fulfill the requirements of EN 250.

Limits (EN 250: 2000)

- **SCUBA – Component units (EN 250: 2000):** The SCUBA equipment may consist of separate component units such as cylinders, regulator and pressure gauge. The MARES regulators described in this manual can be used with other SCUBA unit components certified according to directive EEC/89/686 and EN 250: 2000. The air inside the tanks must conform to the requirements for breathable air set out in EN12021.

DANGER

MARES regulators and octopus are designed and intended for use only with clean, compressed atmospheric air. Do not use this equipment with any other gas.

Failure to adhere to this warning may result in serious injury or death due to fire and explosion or the serious deterioration or failure of the equipment.

- Maximum depth: 50 m/162 feet.
 - Warm water regulators – water temperature over or equal to +10°C (50°F).
 - Cold water regulators – water temperature below +10°C (50°F).
- In accordance with standard EN 250: 2000, cold water is that at temperatures below 10°C.

To use MARES regulators in cold water conditions, always install the CWD (Cold Water Diving) kit. THE CWD KIT SHOULD ONLY BE INSTALLED BY AN AUTHORIZED MARES SERVICE CENTER.

WARNING

Attempting to dive in cold water conditions (10°C or less) without adequate training may result in serious injury. Before diving in cold water, it is advisable to take a special training course under the supervision of a certified diving instructor. Because no regulator can be completely guaranteed against freezing of the second stage under all conditions, even MARES regulators fitted with the CWD kit may be subject to "icing" phenomena. In this event, regulators may not function properly. This may result in serious injury. Therefore, to minimize the potential hazards, it is essential to be adequately trained in the prevention and handling of the problems which may arise from a regulator subject to "icing" phenomena.

Particularly in these situations, the following precautions should be observed:

- 1) Avoid breathing from the regulator outside the water.
- 2) Never operate the purge button when not underwater.

WARNING

For safety reasons, it is not advisable to use an Octopus second stage that is not a certified MARES Octopus. The manufacturer declines responsibility for damages to persons or property resulting from the use of different Octopus second stages. The MARES Octopus second stages have been designed and tested for use on first stage low pressure ports OTHER than the preferential port used for the primary second stage.

WARNING

For safety reasons, the submersible pressure gauge / high pressure safety device to be assembled on the regulator must comply with the standard EN 250: 2000. According to this regulation, with an upstream pressure of 100 bar, the maximum permitted airflow through the connector toward the first stage must not exceed 100 liters/min. If you have a submersible pressure gauge / high pressure safety device that complies with the EN 250:1993 standard or a different specification, check whether the instruction manual indicates the value of the maximum airflow.

The use of submersible pressure gauges / safety devices that do not comply with the EN 250: 2000 standard, or which do not have an indication of the maximum permitted airflow through the first stage connector, may result in serious accidents.

GENERAL WORKING PRINCIPLE

Regulators reduce cylinder pressure, referred to as inlet pressure, to a pressure suitable for breathing. Modern regulators do this in two stages connected by a hose. The first stage provides pressure to the second stage; this reduced pressure remains constant despite the sizeable changes undergone by the cylinder inlet pressure during the dive (dropping from 3000/4350 to few hundred psi). The second stage brings pressure down to ambient pressure and delivers air only when the diver inhales. Each stage of the regulator contains an internal valve. When a pressure imbalance is created inside the respirator due to a withdrawal of air by the diver (beginning of inhalation), the valves open and allow air to flow until the pressure balance is restored (end of inhalation).

FIRST STAGE

For the second stage to work properly, the first stage must deliver air at a correct and – most importantly – constant intermediate pressure. This characteristic, provided by all MARES first stages, is essential for obtaining optimal adjustment of the second stage and ensuring top performance for the entire duration of the dive, regardless of tank pressure. All MARES first stages are available with the following types of tank valve fittings: international YOKE CGA 850 adapter (max pressure 232 bar), or DIN 477/50 connector (max pressure 300 bar), in accordance with the standard EN 250: 2000.

SECOND STAGE

The purpose of the second stage is to deliver air at ambient pressure, only during the inhalation phase. When the diver inhales, the pressure inside the second stage decreases, creating a pressure difference (imbalance) between the two sides of the diaphragm. This pulls the flexible diaphragm inward, pressing the demand lever and unseating the second stage valve. This opening allows air to flow in through the second stage and to the diver, until the diver stops inhaling. At this point the internal second stage pressure increases, pushing the diaphragm back in the opposite direction, causing the valve to return to its seat and shutting off the airflow.

Octopus MV Second stage (Fig.1)

Octopus MV is based on the VAD patent (A), the famous integrated by-pass.

It immediately led to a compact and streamlined shape, a natural extension of the hose.

Consequently, the exhaust tee (B) is laterally opposed to the supply hose (C). The ergonomic advantage is immediate: a perfectly symmetrical octopus second stage that can be used on either side.

The wide diameter of the exhaust valve (D) guarantees optimal exhalation effort.

The cover (E) is very streamlined and is secured using three stainless steel screws on the front (F) tightened into metallic inserts.

The seal on the diaphragm (G) isn't frontal, but radial, which is much more reliable.

Using the Octopus MV second stage is a pleasure.

The reduced weight offers superior comfort without straining the jaw muscles.

Performance, certified by the CE-EN 250: 2000 regulations, ensures minimal breathing effort even in extreme conditions.

Thanks to the updated VAD, breathing is entirely natural.

Every detail has been meticulously crafted and tested to wed the highest possible quality with simple functionality.

The MV octopus positions itself ideally on the BC, and is immediately in the perfect position for use.

The option to use it freely on either side makes it especially versatile.

Integrated V.A.D. system

The Octopus MV second stage uses the integrated V.A.D. (Vortex Assisted Design) system. This system guarantees a low breathing effort at any depth, so that as the air from the hose passes through the second stage valve, it is routed directly to the mouthpiece via the by-pass tube (Fig. 1). Inside the latter there is a depression which helps hold down the second stage diaphragm during inhalation, thus increasing the sensitivity of the regulator. The V.A.D. system also improves performance during dives in especially cold water (colder than 10°C / 50°F). In fact, with the V.A.D. system, the expansion of air in the second stage occurs inside a by-pass tee and in the mouthpiece, away from the second stage valve/lever, thus lowering the risk of ice forming.

NBS System (patented)

The Octopus MV second stage uses the new NBS (Natural Breathing System).

The introduction of a new patented system allows breathing to be more comfortable, that has been made possible through countless tests and research.

A special spiral-shaped insert is placed inside the by-pass tube (Fig. 1 – A). With such a special insert, airflow can be adjusted, making breathing more natural under any condition.

OCTOPUS MV TECHNICAL FEATURES	Octopus
VAD (Vortex Assisted Design)	INTEGRATED
USE 2ND STAGE	SYMMETRICAL (RIGHT AND LEFT)
MATERIALS Metal parts Non-metal parts Gaskets	Chrome- and nickel-plated brass, stainless steel High impact technopolymers Nitril rubbers, silicone rubbers
TEFLON-COATED 2ND STAGE DEMAND LEVER	Stainless steel
CAPACITY With supply at 180 bar	2300 l/min
HOSE Type Octopus length	super soft 3/8" 100 cm
Weight (gr)	175 gr

USE AND MAINTENANCE

WARNING

DO NOT attempt to use your regulator unless you have performed all of these pre-dive operating procedures. The LP components are not designed for use with pressures higher than 285 psi.

Connecting the hoses to the first stage

The hoses and accessories should be connected in such a way as to avoid damaging the O-ring. Use a suitable wrench to remove the plug from the first stage port, and screw the terminal fitting of the hose firmly but gently into the first stage port.

WARNING

The regulator in and of itself is not a complete SCUBA unit, but only one of its components. Under the EN 250: 2000 standard, a complete SCUBA unit must include at least the following Minimum Equipment:

- Air cylinder / cylinders.
- Regulator.
- Safety device, e.g. pressure gauge / computer or reserve or alarm.
- Carrying frame or holding device, e.g. backpack and/or strap.
- Facepiece (mouthpiece assembly or full face mask or diving helmet).
- Operating instructions.

Your MARES regulator has been designed for use in conjunction with other SCUBA unit components conforming to the EEC/89/686 directive and certified with the EC mark. The air inside the tanks must conform to the requirements for breathable air set out in EN12021.

BEFORE ASSEMBLING THE COMPONENTS OF YOUR SCUBA UNIT, CAREFULLY READ ALL THE USER INSTRUCTIONS AND ANY WARNINGS WHICH THEY CONTAIN.

PRE-DIVE CHECKLIST

- Ensure that all the hoses have been correctly assembled onto the 1st stage, and check them for cuts, signs of wear or other damage. If the hoses are loose enough to be unscrewed manually, they must be tightened with a wrench before being pressurised.
- Make sure that the first and second stages do not show signs of damage.
- Position the tank control valve so that the valve opening is directed towards the diver.
- Remove the dust cap from the regulator yoke and position the A-clamp or DIN fitting so that it is centered on the tank valve opening.
- The first stage should be oriented in such a way that the hose leading to the second stage is routed over the diver's shoulder (Fig. 2).
- Tighten the yoke nut finger tight only, being careful not to damage the O-Ring on the tank valve.
- Check the submersible pressure gauge, making sure that the pressure reading is zero.
- Very slowly open the tank valve, allowing air to enter the regulator gradually.
- Do not turn the first stage connected to the tank when the system is pressurized!!

WARNING

When opening the air valve, press the purge valve of the second stage. This helps to reduce the impact on the valve (Fig. 3). DO NOT PERFORM THIS OPERATION AT AMBIENT TEMPERATURES BELOW 10°C (50°F).

- Check the pressure gauge to ensure that it indicates the proper cylinder pressure for your planned dive.
- Check the cylinder and regulator connection for leakage. If leakage exists, it may be caused by incorrectly mounting the regulator on the valve or by a damaged cylinder valve O-ring.
- To confirm that the regulator delivers air properly, first exhale through the mouthpiece to blow any foreign matter from the second stage, then inhale. A few breathing cycles should indicate if there are any obvious problems that cannot be discovered by actually breathing from the regulator while underwater.

DURING THE DIVE

When the regulator is out of the diver's mouth, free flowing of air may occur. This inconvenience may be easily eliminated by turning the regulator downward and lightly shaking it to fill it with water (Fig. 4). Should free flow continue, abort the dive immediately..

POST-DIVE CARE AND PERIODIC MAINTENANCE

Ideally, your regulator should be rinsed with fresh water while pressurized. This allows the second stage to be rinsed internally without introducing contaminants into critical sealing areas. Rinse the first stage and also run water into the mouthpiece of the second stage and out of the exhaust tees to remove foreign matter. If the regulator is not pressurized, do not depress the purge button while rinsing. Actuation of the purge function may allow particles to contaminate the valve seat and cause leakage. In order to avoid filter and first stage contamination, prevent water from entering the first stage air inlet. Cover the first stage filter with the special dust cup (Fig. 5). Allow the regulator to dry thoroughly before putting it away. If the regulator is exposed for prolonged periods to direct sunlight, or left in greasy or dusty environments, some of its components may be damaged. Do not use lubricants. Lubricants should never be used in routine care and maintenance.

WARNING

The correct functioning of the regulator is dependent upon proper maintenance. Therefore, your regulator should be submitted to a MARES authorized service center for inspection at least once a year. It is also recommended that the first stage valve be replaced every two years or every 200 diving hours.

WARRANTY

With the purchase of a MARES regulator, you receive a Permanent "Original Owner Identification Card" made of durable plastic. Your card will have the model and serial number embossed on it. Please print your name and sign in the appropriate space provided. Retain this card and present it whenever periodic maintenance of the regulator is performed by any MARES Authorized Service Center worldwide.

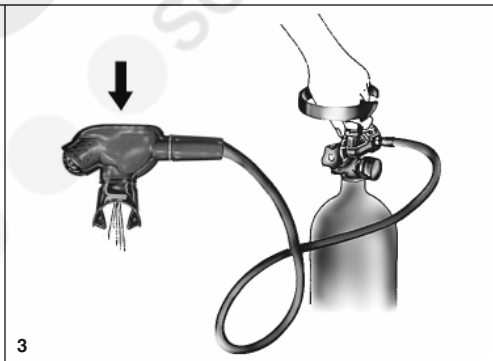
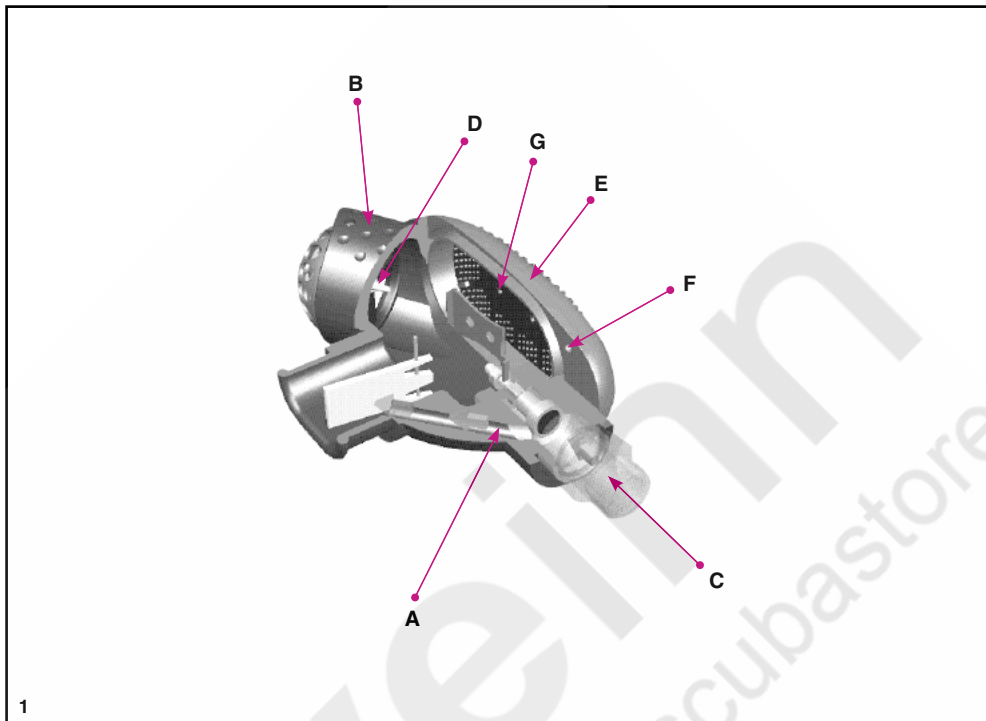

diveinn
scubastore



Mares S.p.A. - Salita Bonsen, 4 - 16035 RAPALLO - ITALY - Tel. +39 01852011 - Fax +39 0185669984
www.mares.com