

LOWRANCE®

Traditional Sonar and DSI Sonar Installation

This document covers the installation of the transducer and display unit installation, which includes connecting the unit to power and installing the unit on the bracket mount.

The first section of the document covers the installation of a traditional sonar skimmer transducer. DSI sonar installation is covered in the last section of the manual.

Make sure you read all the installation instructions before drilling holes in your vessel!



NOTE: *This majority of this installation does not apply to the GPS only units since they do not have a transducer. Turn to pages 8-11 for information on mounting the display unit and connecting the unit to power.*

Traditional Sonar Transducer Installation

One piece bracket (Recommended Tools and Supplies — not included)	
Drill	Marine grade above-or-below waterline sealant
1" (25mm) or 5/8" (15mm) drill bit	Marine grade epoxy (Shoot-thru-hull install only)
#29 (0.136") (3mm) drill bit	Zip ties (trolling motor mount)
Phillips (Slotted-head) screwdriver	TMB-S bracket kit (Skimmer trolling motor mount)

Traditional Sonar

A. Select a transducer location

To function properly the Skimmer transducer must be in the water at all times and in a location that has a smooth flow of water when the boat is moving. If the transducer is not placed in a smooth flow of water, interference caused by bubbles and turbulence may show on-screen as random lines or dots. The unit also could lose bottom signal when the boat is on plane.



NOTE: Mount the transducer at least one foot away from the engine lower unit.

B. Aligning Ratchets on bracket

You will use the ratchets to ensure the transducer is installed parallel to the ground.

1. Insert the ratchets in the bracket with the letter "A" aligned with the dot stamped on the outside of the transducer bracket.

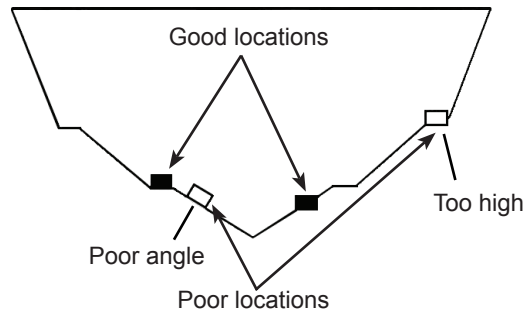

2. Slide the transducer into the bracket and temporarily slide the bolt through the transducer bracket.

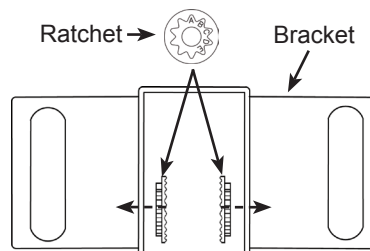

Traditional Sonar

3. Hold the transducer assembly against the transom. Look at the transducer from the side. If it is parallel to the ground, then the "A" position is correct.

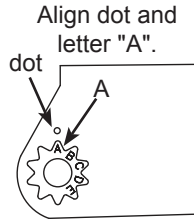

4. If the transducer can not be adjusted so its face is parallel to the ground, remove the transducer and ratchets from the bracket. Reinsert the ratchets into the bracket, this time with the letter "B" aligned with the dot stamped in the bracket. Reassemble the transducer and bracket and place it against the transom.

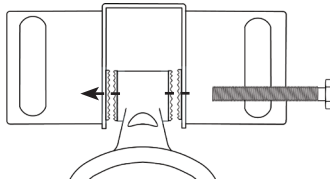

5. Check to see if the transducer will adjust so its face is parallel with the ground. Repeat this process until the transducer can be adjusted so its face is parallel with the ground.

C. Assembling the bracket

After determining the correct position for the ratchets, loosely assemble the transducer and bracket assembly.

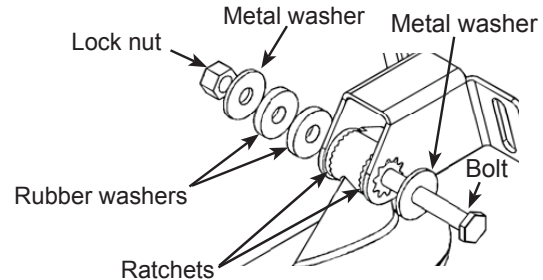

Traditional Sonar

D. Attaching Transducer to Transom

1. Adjust the transducer so its face is parallel with the ground and its center line is even with the bottom of the boat hull.
2. Hold the transducer and bracket assembly against the transom. When the transducer and bracket are properly aligned mark its position on the hull.
3. Drill the mounting holes for the transducer bracket. Use a #29 bit (for the #10 screws).

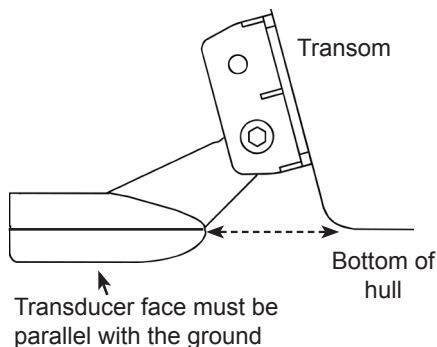

Run the cable over the bolt and through the bracket.

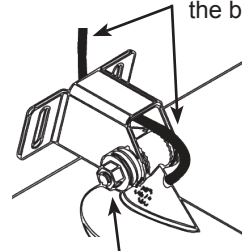

Do not over tighten the lock nut; otherwise transducer may not kick-up if it strikes an object.

Routing cables

When mounting your transducer, make sure to leave some slack in the cable near the transducer. If you need to drill a hole in the transom to pass the connector through, the hole size will depend on the connector on the end of the transducer's cable.

E. Make test run to determine results

After the transducer is installed make a test run to ensure the transducer is installed properly. Use the

Traditional Sonar

slots in the transducer mounting bracket to loosen the screws and slide the transducer up or down, if adjustments are necessary.

Shoot-thru-hull Skimmer and Pod transducer installation

Before attempting any installation on boats with flotation material sandwiched within the hull, consult the boat manufacturer. In a shoot-thru-hull installation the transducer is epoxied to the inside of the boat hull.

WARNING: Do not remove material from the inner hull. Careless grinding on the hull could damage hull integrity. Contact the boat dealer or manufacturer to confirm hull specifications.

A transducer can not shoot through wood or metal hulls. Wood and metal hulls require either a transom mount or thru-hull installation. For shoot-thru-hull applications many boat hulls have a flat

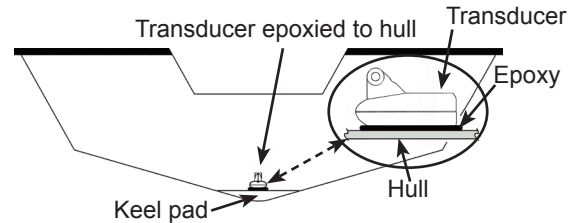

keel pad that offers a good transducer mounting surface.

Make sure the Skimmer transducer is oriented so the nose of the transducer is facing the bow (front) of the boat. If the transducer has a built in temp sensor, it will only show the temperature of the hull, not the water temp.

Before you epoxy the transducer to the hull, make sure the area is clean, dry and free of oil or grease. The surface of the hull must be flat so the entire

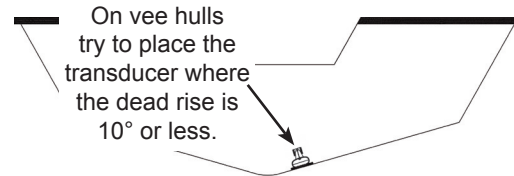

Traditional Sonar

transducer face is in contact with the hull. Also, make sure the cable is long enough to reach the sonar unit.

To use shoot-thru-hull installation:

1. Sand the inside surface of the hull, where the transducer is to be epoxied, and the face of the transducer. Sand the hull until it is smooth to the touch. The sanded area should be about 1-1/2 times the diameter of the transducer.
2. After sanding, clean the hull and the face of the transducer with an alcohol wipe to remove any dust.
3. Apply a thin layer of epoxy (about 1-16" or 1.5 mm) on the face of the transducer and the sanded area on the hull. **Be careful when mounting a transducer inside a boat hull. Once epoxied into position, the transducer can be very difficult to remove. Epoxy is available at www.lei-extras.com (Part No. 106-98).**

Sand transducer face and mounting location

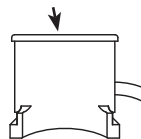

Apply epoxy to transducer face and mounting location.

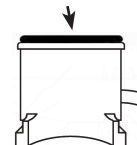

4. Press the transducer into the epoxy, turning it to force out any air bubbles from under the transducer face. **Make sure there are no air pockets in the epoxy layers.**

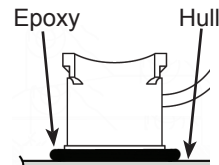

5. Stop pressing when it bottoms out on the hull. Epoxy transducer to hull. Apply pressure to hold the transducer in place while the epoxy sets. Be careful not to move the transducer while the epoxy is setting. Allow the epoxy to set before moving the boat.

- When finished, the face of the transducer should be parallel with the hull with a minimum amount of epoxy between the hull and transducer.

Trolling motor Skimmer and Pod Installation

The TMB-S trolling motor bracket (Part No. 51-45) is an *optional* accessory and is available through LEI Extras at www.lei-extras.com. The TMB-S bracket is used to attach a one-piece bracket skimmer transducer to a trolling motor. The Pod transducer does not need a TMB-S trolling motor bracket to be installed on a trolling motor. It only needs a hose clamp (adjustable strap).

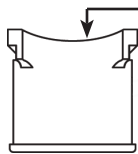

The top of the Pod transducer is curved to fit the contour of the trolling motor, so you do not need a TMB-S mounting bracket.

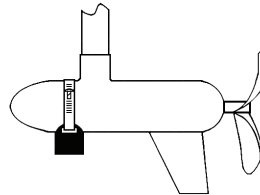

Position the transducer so its face is pointing straight down when the trolling motor is in the water.

Installing transducer on trolling motor:

- Attach the skimmer transducer to the bracket as shown in the diagram.

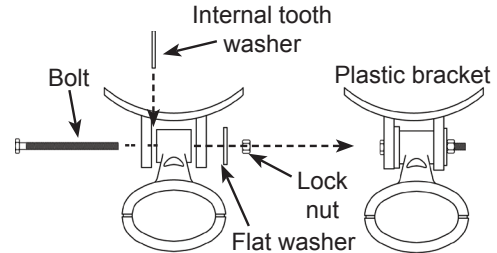

- Slide the adjustable strap (hose clamp) through the plastic bracket on the skimmer transducer or through the Pod transducer slots and then slip the strap around the trolling motor.

Traditional Sonar

3. Position the transducer so its face is pointing straight down when the trolling motor is in the water.

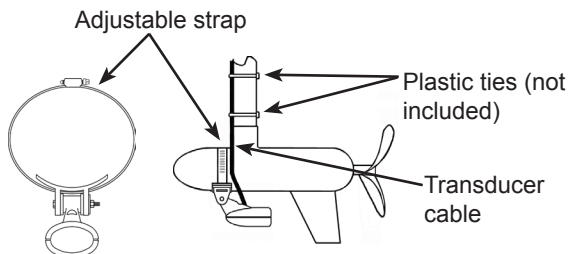

4. Tighten the adjustable strap securely to the trolling motor. Make sure there is enough slack in the transducer cable for the trolling mount to turn freely.

Connecting the unit to power

1. Connect the black wire to a ground.
2. Attach a 3 Amp fuse (not included) to the end of the power wire and then connect the fuse to the positive (+) terminal on the battery.
3. Connect the Power cable to the Power port on the back of the display unit.



NOTE: Use 18 gauge wire to extend the power or ground wires.

Traditional Sonar

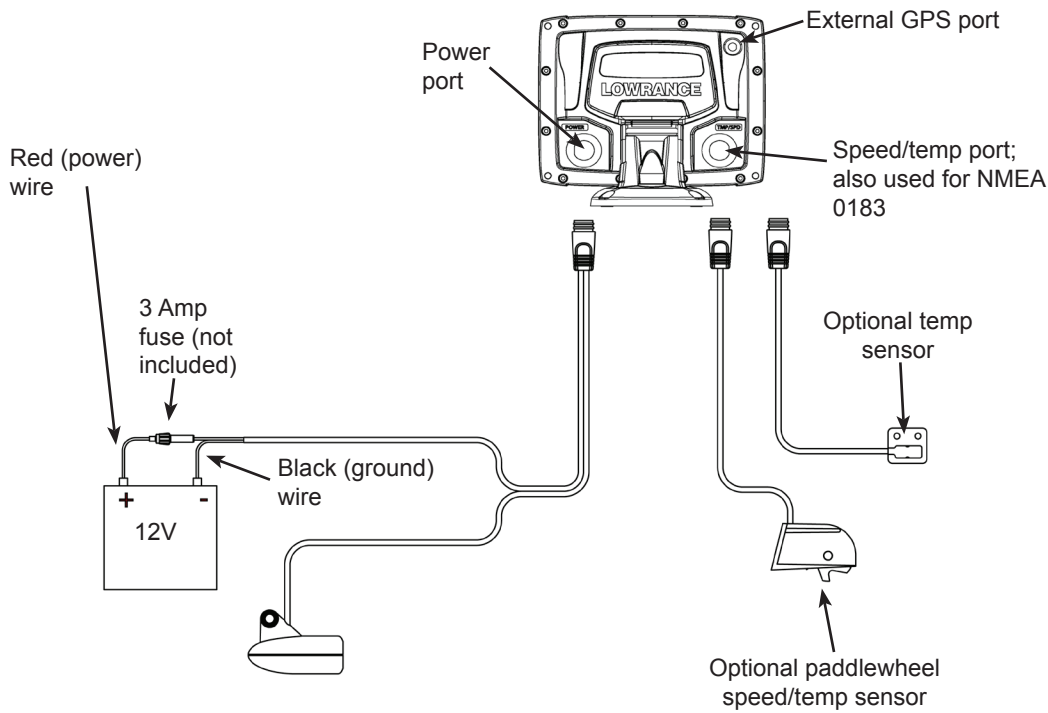

Traditional Sonar

NMEA 0183 Connection Diagram (GPS capable units only)

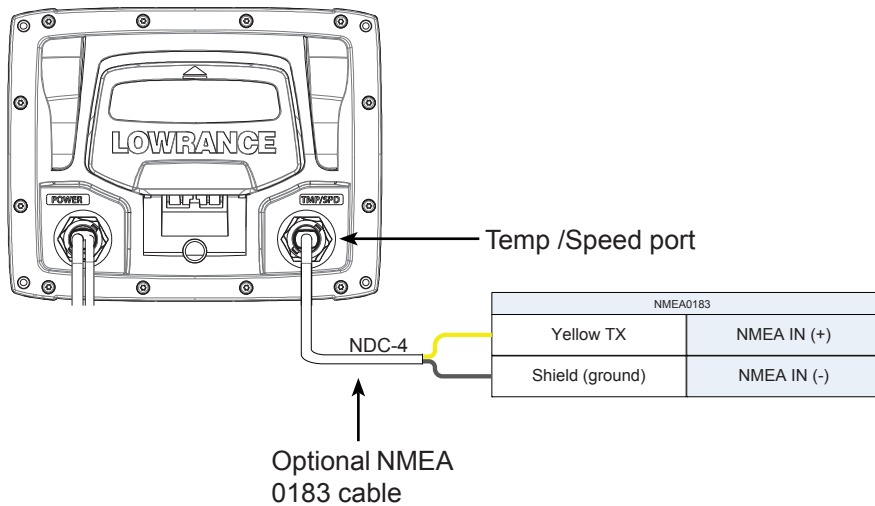

Mounting the display unit

Before mounting the display unit mount, make sure there is nothing in the area that will obstruct the display unit when it is installed on the bracket.

To install bracket mount:

1. Place the bracket on the desired mounting surface and mark the four mounting holes. If you want to run the unit's cables up through the mounting surface, make a mark in the center of the bracket mounting surface.
2. Drill pilot holes for the four mounting holes. If desired, use a 1-inch (25mm) bit to drill the center cabling hole in the mounting surface.
3. If you are running the cables up through the mounting surface, push the cables through the mounting surface and then pull them through the cabling hole in the center of the bracket.
4. Align the mounting bracket with the four mounting holes and use the supplied screws to fasten it to the mounting surface.
5. Connect the display unit to the bracket mount.

Display unit

Removing the unit from the bracket

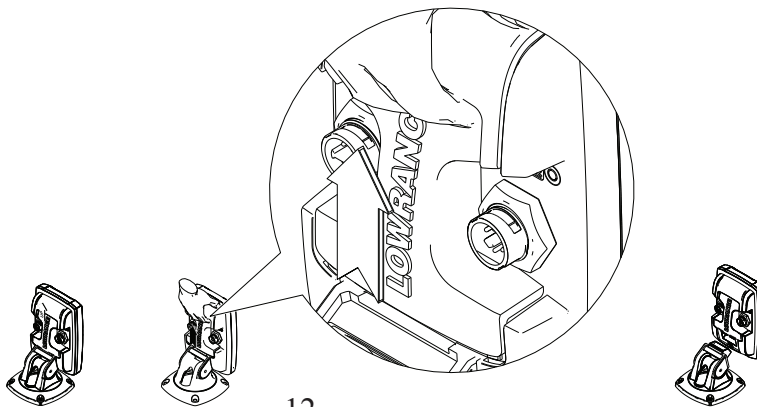
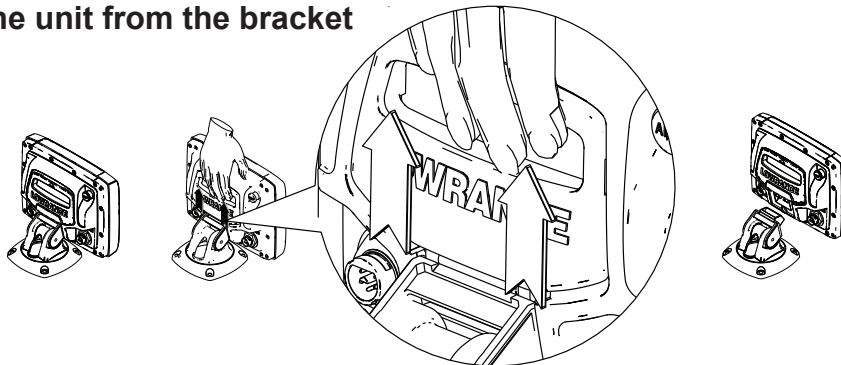

12

DSI Series Installation

This document covers the installation of the DSI series transducer and display unit installation.



WARNING: Make sure you read all installation instructions before drilling holes in your vessel.

(Tools and Supplies — not included)	
Drill	Marine grade below waterline sealant
1" (25mm) or 5/8" (15mm) drill bit	Zip ties (trolling motor mount)
#29 (0.136") (3mm) drill bit	Trolling motor accessory kit
Slotted-head (Phillips) drill bit	FM-ME5 flush mount kit (pn: 000-10028-001) (optional)

Transducer bracket assembly

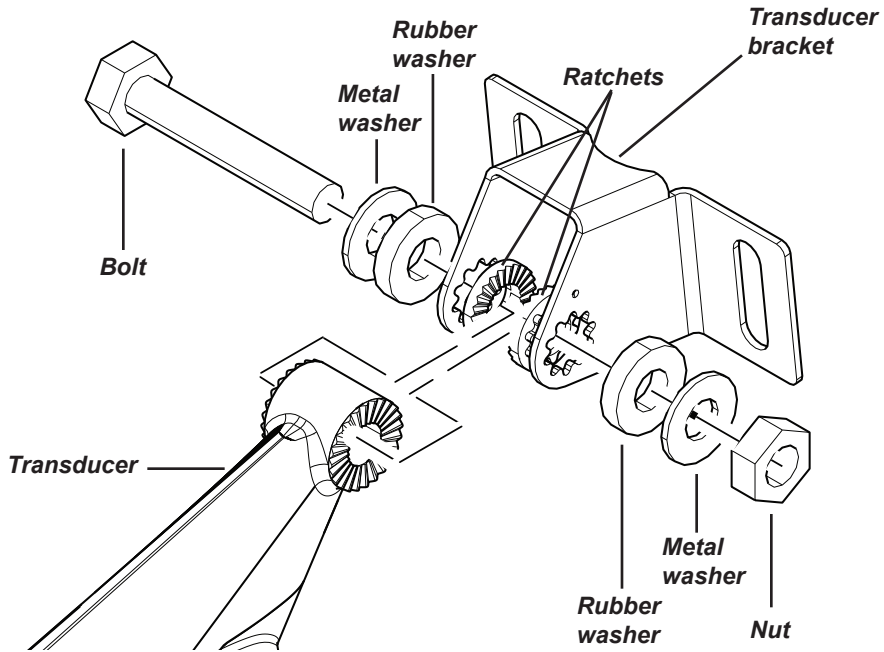

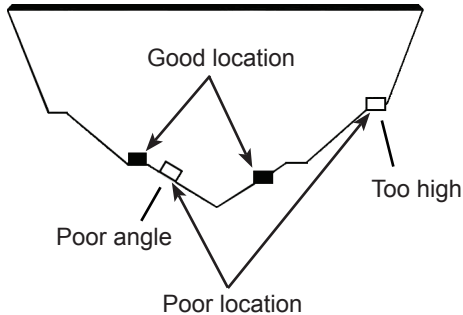

Selecting transducer location

The DSI transducer must be in the water at all times and in a location that has a smooth flow of water when the boat is moving.

If it is not placed in a smooth flow of water, interference from bubbles and turbulence may diminish product performance. The unit also could lose bottom signal when the boat is on plane.

Install the transducer at least 1' (.3m) away from the engine's lower unit.

Aligning transducer ratchets

Ratchets are used to ensure the transducer is installed parallel to the ground.

1. Insert the ratchets in the bracket with the letter "A" aligned with the dot stamped on the outside of the transducer bracket.
2. Slide the transducer into the bracket and temporarily slide the bolt through the transducer bracket.

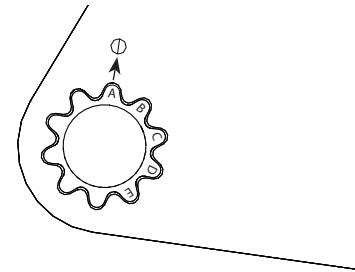

DSI Sonar

3. Hold the transducer assembly against the transom. Look at the transducer from the side. If it is parallel to the ground, then the “A” position is correct.
4. If the transducer can not be adjusted so its face is parallel to the ground, remove the transducer and ratchets from the bracket. Reinsert the ratchets into the bracket, this time with the letter “B” aligned with the dot stamped in the bracket. Reassemble the transducer and bracket and place it against the transom.
5. Repeat this process until the transducer can be adjusted so its face is parallel with the ground.

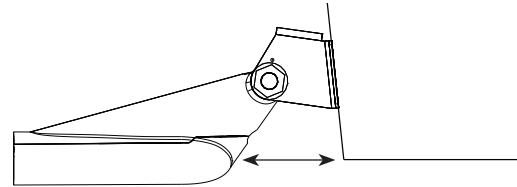

2. Hold the transducer and bracket assembly against the transom. When the transducer and bracket are properly aligned mark its position on the hull.

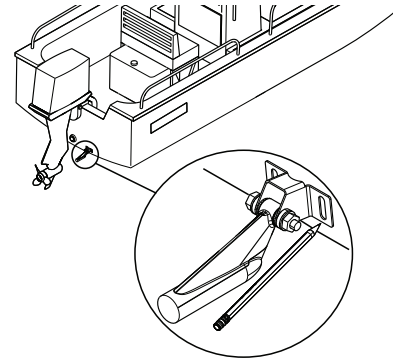

Mounting to transom

1. Adjust the transducer so its face is parallel with the ground and its center is even with the bottom of the boat hull.

3. Drill the mounting holes for the transducer bracket. Use a #29 bit (for the #10 screws).
4. Attach the transducer to the transom using the supplied screws (2).

Shoot-thru hull

The DSI transducer can be epoxied to the hull for shoot-thru installations. This is not a recommended installation method since it significantly degrades DSI performance.

Mounting on trolling motor

The optional DSI trolling motor accessory (pn: 000-10261-001) is available through LEI Extras at www.lei-extras.com. The Trolling motor accessory allows you to mount the DSI transducer to a trolling motor. You must remove the factory installed transducer mount from the transducer housing before you can install the DSI transducer on a trolling motor.

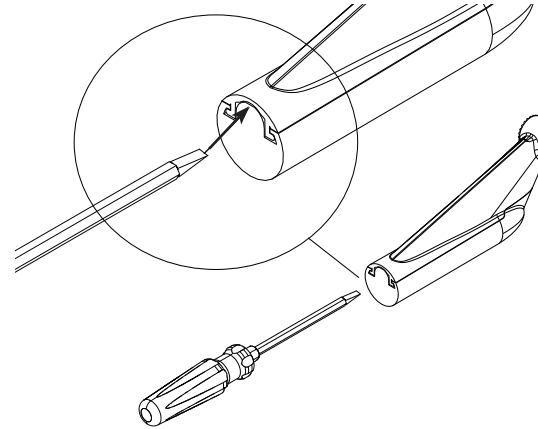

Using a flathead screwdriver, depress the release tab and slide off the transducer mount.

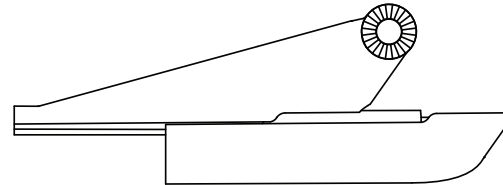

DSI Sonar

Installing transducer on trolling motor:

1. Place the DSI transducer inside the trolling motor housing.
2. Slide the adjustable strap (hose clamp) through the slots in the trolling motor housing and slip the strap around the trolling motor.

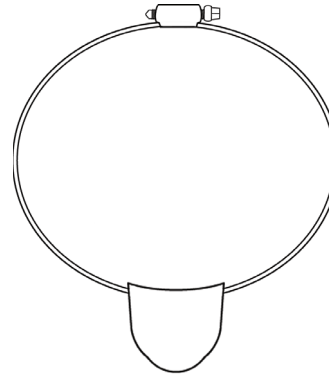
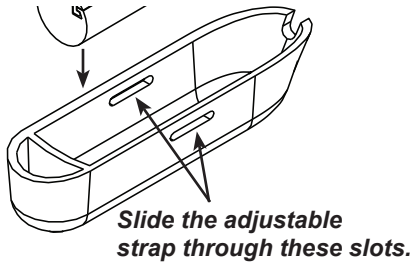

3. Position the trolling motor housing so its face is pointing down when the trolling motor is in the water.
4. Tighten the adjustable strap securely to the trolling motor. Make sure there is enough slack in the transducer cable for the trolling motor to turn freely.

DSI Wiring Diagram

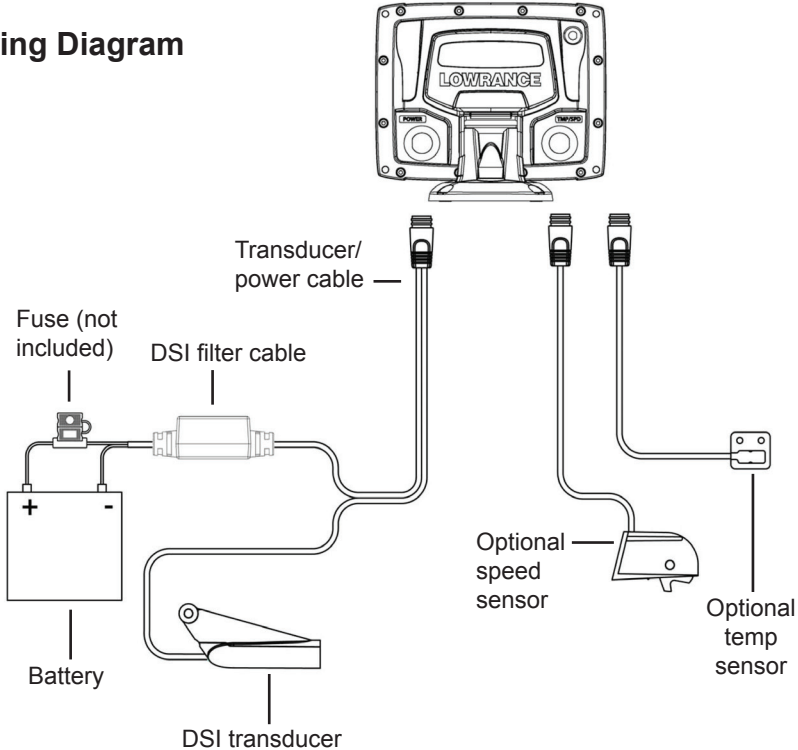

NMEA 0183 Connection Diagram (GPS capable units only)

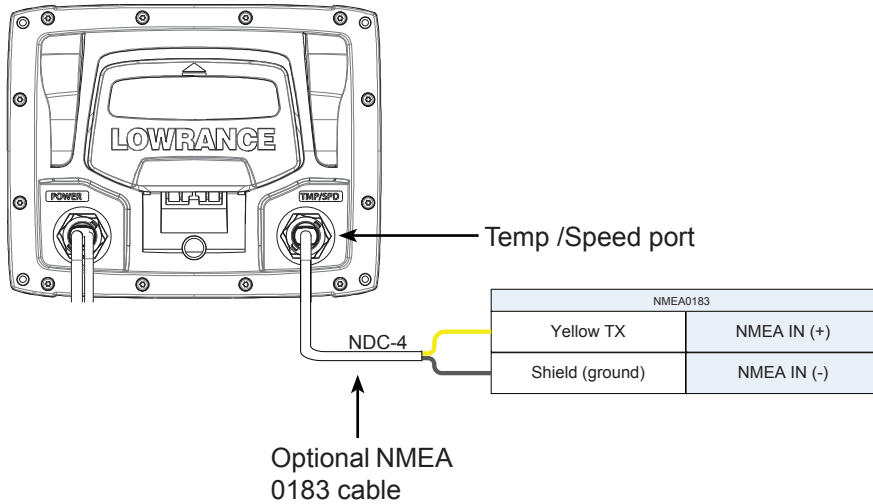



Visit our website:
www.lowrance.com



Copyright © 2011
All Rights Reserved
Navico Holding AS