

Headboard Car Assemblies

Intermediate Cars

CB BALL BEARING CARS

SLIDER CARS

CB BALL BEARING CARS

SLIDER CARS



Batten Cars

CB BALL BEARING CARS

SLIDER CARS



Part No.	Description	Length		Width		Weight		Max headboard thickness		Max batten			Batten	Maximum working load		
		in	mm	in	mm	oz	g	in	mm	in	mm	in		mm	lb	kg
CB Cars: Typical Boat Length: Monohulls 11.3 - 15.2 m (37 - 50 ft); Multihulls 9.1 - 12.2 m (30 - 40 ft)																
3811	Headboard car assembly	8 ³ / ₈	213	2 ¹ / ₄	57	18	518	9 ⁹ / ₁₆	14	—	—	—	—	—	1600	725
3812	Intermediate car	2 ¹ / ₄	57	2 ¹ / ₄	57	4	109	—	—	—	—	—	—	—	—	—
3829	Battcar/10 mm stud**	2 ⁷ / ₈	73	2 ¹ / ₄	57	6	157	—	—	—	—	—	—	—	600	272
3830	Battcar/40 mm receptacle	2 ⁷ / ₈	73	2 ¹ / ₄	57	9	253	—	—	1 ⁵ / ₈	41	5 ⁵ / ₈	16	Flat/round	600	272
3881	Battcar/12 mm stud**	2 ⁷ / ₈	73	2 ¹ / ₄	57	6.4	182	—	—	—	—	—	—	—	600	272
3831	Universal Battcar**	2 ⁷ / ₈	73	2 ¹ / ₄	57	4.3	122	—	—	—	—	—	—	—	600	272
3882	Batten car/12 mm stud**	4 ¹ / ₈	105	2 ¹ / ₄	57	8.2	232	—	—	—	—	—	—	—	875	397
3883	Reef car	4 ¹ / ₈	105	2 ¹ / ₄	57	6.1	174	—	—	—	—	—	—	—	875	397
Slider Cars: Typical Boat Length: Monohulls 11.3 - 15.2 m (37 - 50 ft); Multihulls 9.1 - 12.2 m (30 - 40 ft)																
3827	Headboard car assembly	6	153	1 ¹ / ₄	35	10	269	9 ⁹ / ₁₆	14	—	—	—	—	—	1600	725
1777	Low-load intermediate car*	2	51	1 ¹ / ₄	32	1.1	32	—	—	—	—	—	—	—	200	91
3828	Intermediate car	1 ³ / ₄	44	1 ³ / ₈	35	1.6	45	—	—	—	—	—	—	—	350	159
3802	Battcar/10 mm stud**	1 ³ / ₄	44	1 ³ / ₈	35	2.8	80	—	—	—	—	—	—	—	350	159
3803	Battcar/40 mm receptacle	1 ³ / ₄	44	1 ³ / ₈	35	6.4	181	—	—	1 ⁵ / ₈	41	5 ⁵ / ₈	16	Flat/round	350	159

**Track mounting kit
3804, 3805, 3806**

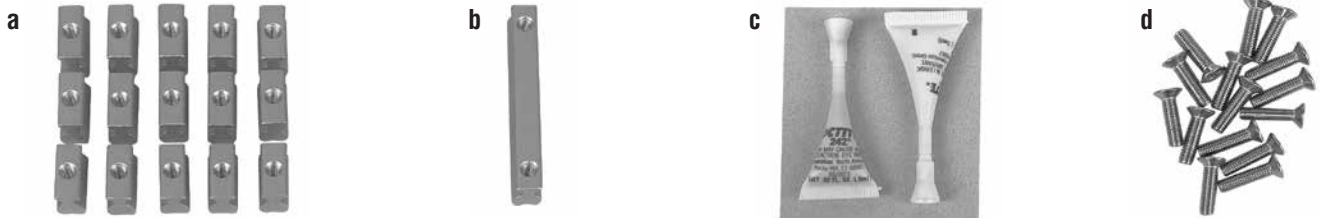

**Screwpin endstop kits
3824, 3825, 3826**

**Endstop kits
3808, 3809, 3810**

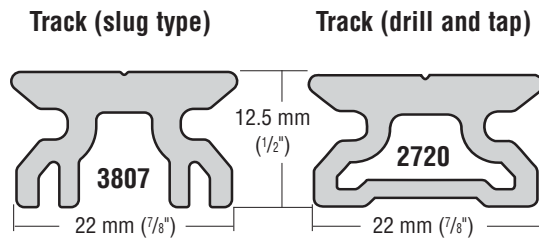
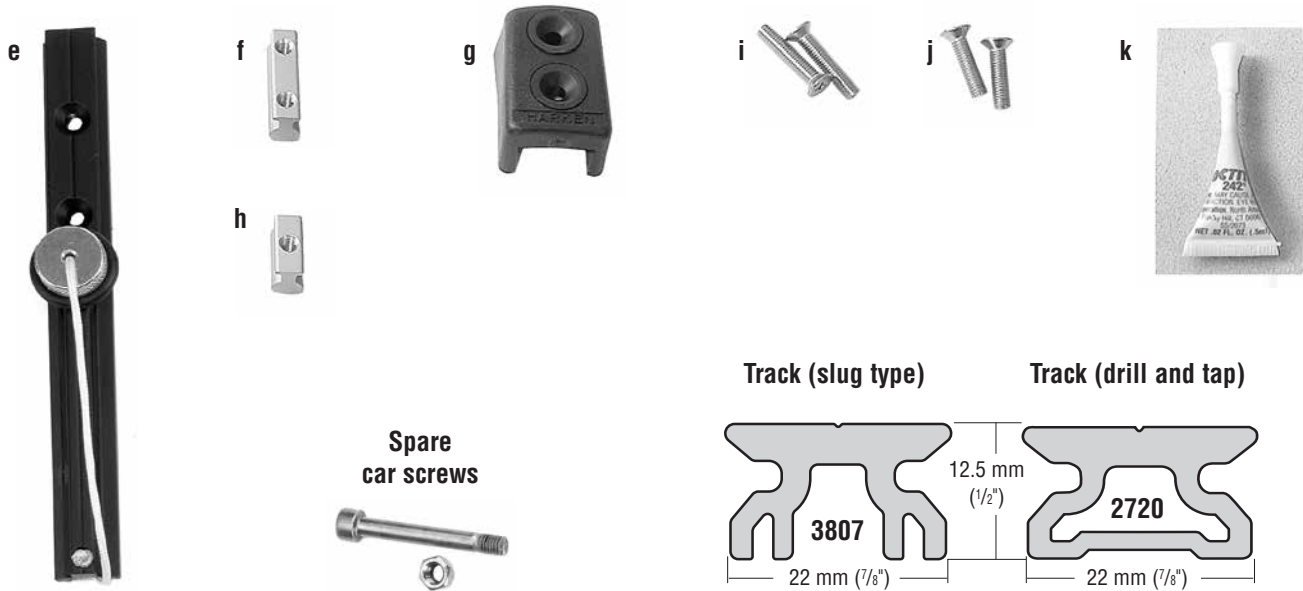

Track and Accessories

Part No.	Description	Includes
Mounting Slug Method		
3804, 3805 3806	Track mounting kit	(a) 15 mounting slugs 19 mm (3/4"); (b) 1 connector slug 67 mm (2 5/8"); (c) 2 tubes blue Loctite® adhesive; (d) 17 HFS1015 flathead screws 5 x 20 mm
3824, 3825 3826	Screwpin endstop kt	(e) 1 end track with screwpin stop; (f) 1 top stop slug 32 mm (1 1/4"); (g) 1 top endstop 263A; (h) 1 mounting slug 19 mm (3/4"); (i) 2 HFS320 flathead screws 5 x 25 mm; (j) 2 HFS1015 flathead screws 5 x 20 mm; (k) 1 tube blue Loctite® adhesive
3808, 3809 3810	Endstop kit	(g) 2 endstops 263A; (i) 4 HFS320 flathead screws 5 x 25 mm; (f) 2 stop slugs 32 mm (1 1/4")
3807	Track	Section length: 2.05 m (6'8 7/8"). Number of track sections will vary according to luff length of your mainsail.
Drill & Tap Method		
2720	Track	Use for masts without grooves or when slugs will not fit. Purchase stainless steel #10 (5 mm) screws separately. Do not use 3807 open-backed track. It requires mounting slugs. See page 8 for drill/tap sizes and mounting instructions.

Loctite is a registered trademark of Henkel AG & Company KGaA.

HARKEN®

BATTCAR INSTALLATION MANUAL

System A CB and Slider

Installation Manual – Intended for specialized personnel or expert users

4248 10/14



Introduction

Safety precautions	2
--------------------	---

Preassembly (Slug Mount/Drill & Tap)

Parts	3
Tools	4
Sizing	4
Sail modifications	4
Track length (slug mount only)	4 - 5
Cutting top track to length (slug mount only)	6
Check fit of mounting slugs/cars (slug mount only)	7

Installation (Slug Mount)

Install track	8 - 10
Install screwpin endstop kit	10

Preassembly (Drill & Tap)

Parts	4, 11
Track length	11
Remove old track	11

Installation (Drill & Tap)

Drill, tap, and fasten	11
------------------------	----

Operation (Slug Mount/Drill & Tap)

Load cars on track	12
Load cars on track with sail attached	13
Lost balls	13
Load cars on track with sail attached (slider)	14
Load sail on cars (CB/slider)	14 - 15

Maintenance (Slug Mount/Drill & Tap)

Removing sail	16
Car maintenance/cleaning/inspect	16
Lazy Jacks	16
Operating precautions	16

Sailmaker's Instructions (Slug Mount/Drill & Tap)

Dimensions	17
Installing headboard car assembly	17
Headboard plates	17
Battcars with batten receptacles	18 - 19
Distance between attachment points/reef points	20
Attaching sail to intermediate cars	21

Troubleshooting – Installation/Operation

22

Addresses

24

Please read these instructions carefully before installing, servicing, or operating the equipment.

This manual may be modified without notice: www.harken.com/manuals for updated versions.

PLEASE SAVE THESE INSTRUCTIONS

Introduction

This manual gives technical information on installation and service. This information is **written exclusively** for specialized personnel or expert users. Installation, disassembling, and reassembling by personnel who are not experts may cause serious damage to property, or injury to users and those in the vicinity of the product. If you do not understand an instruction, contact Harken.

The user must have appropriate training in order to use this product.

Harken accepts no responsibility for damage or harm caused by not observing the safety requirements and instructions in this manual. See limited warranty, general warnings, and instructions in www.harken.com/manuals.

Purpose

Harken Battcars are designed to reduce the size of, or completely drop the mainsail on a sailboat so wind has little effect on the sail. Use of this product for other than normal sailboat applications is not covered by the limited warranty.

Safety Precautions



WARNING! This symbol alerts you to potential hazards that may kill or hurt you and others if you don't follow instructions. The message will tell you how to reduce the chance of injury.



CAUTION! This symbol alerts you to potential hazards that may hurt you and others if you do not follow instructions. The message will tell you how to reduce the chance of injury.



WARNING! Strictly follow all instructions to avoid potential hazards that may kill or hurt you and others: www.harken.com/manuals for general warnings and instructions.

Headboard Car Assemblies

Intermediate Cars

CB BALL BEARING CARS

SLIDER CARS

CB BALL BEARING CARS

SLIDER CARS



Batten Cars

CB BALL BEARING CARS

SLIDER CARS



Part No.	Description	Length		Width		Weight		Max headboard thickness		Max batten			Batten	Maximum working load	
		in	mm	in	mm	oz	g	in	mm	in	mm	in		mm	lb
CB Cars: Typical Boat Length: Monohulls 11.3 - 15.2 m (37 - 50 ft); Multihulls 9.1 - 12.2 m (30 - 40 ft)															
3811	Headboard car assembly	8 ³ / ₈	213	2 ¹ / ₄	57	18	518	9 ⁹ / ₁₆	14	—	—	—	—	1600	725
3812	Intermediate car	2 ¹ / ₄	57	2 ¹ / ₄	57	4	109	—	—	—	—	—	—	200	91
3829	Battcar/10 mm stud**	2 ⁷ / ₈	73	2 ¹ / ₄	57	6	157	—	—	—	—	—	—	600	272
3830	Battcar/40 mm receptacle	2 ⁷ / ₈	73	2 ¹ / ₄	57	9	253	—	—	1 ⁵ / ₈	41	5 ⁵ / ₈	16	Flat/round	600 272
3881	Battcar/12 mm stud**	2 ⁷ / ₈	73	2 ¹ / ₄	57	6.4	182	—	—	—	—	—	—	600	272
3831	Universal Battcar**	2 ⁷ / ₈	73	2 ¹ / ₄	57	4.3	122	—	—	—	—	—	—	600	272
3882	Batten car/12 mm stud**	4 ¹ / ₈	105	2 ¹ / ₄	57	8.2	232	—	—	—	—	—	—	875	397
3883	Reef car	4 ¹ / ₈	105	2 ¹ / ₄	57	6.1	174	—	—	—	—	—	—	875	397
Slider Cars: Typical Boat Length: Monohulls 11.3 - 15.2 m (37 - 50 ft); Multihulls 9.1 - 12.2 m (30 - 40 ft)															
3827	Headboard car assembly	6	153	1 ¹ / ₄	35	10	269	9 ⁹ / ₁₆	14	—	—	—	—	1600	725
1777	Low-load intermediate car*	2	51	1 ¹ / ₄	32	1.1	32	—	—	—	—	—	—	200	91
3828	Intermediate car	1 ³ / ₄	44	1 ³ / ₈	35	1.6	45	—	—	—	—	—	—	350	159
3802	Battcar/10 mm stud**	1 ³ / ₄	44	1 ³ / ₈	35	2.8	80	—	—	—	—	—	—	350	159
3803	Battcar/40 mm receptacle	1 ³ / ₄	44	1 ³ / ₈	35	6.4	181	—	—	1 ⁵ / ₈	41	5 ⁵ / ₈	16	Flat/round	350 159

**Track mounting kit
3804, 3805, 3806**

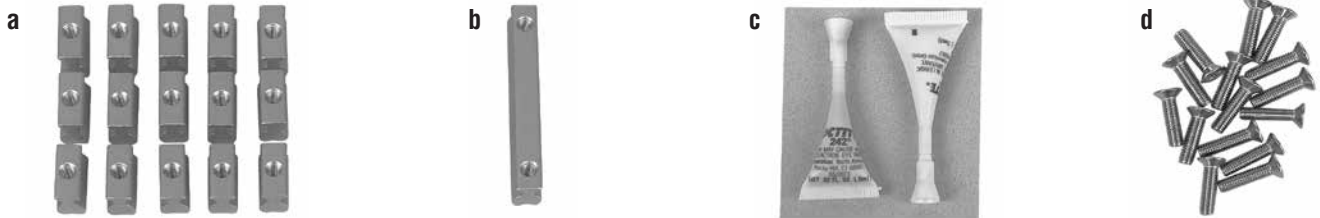

**Screwpin endstop kits
3824, 3825, 3826**

**Endstop kits
3808, 3809, 3810**

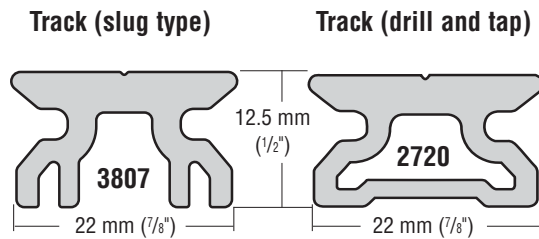
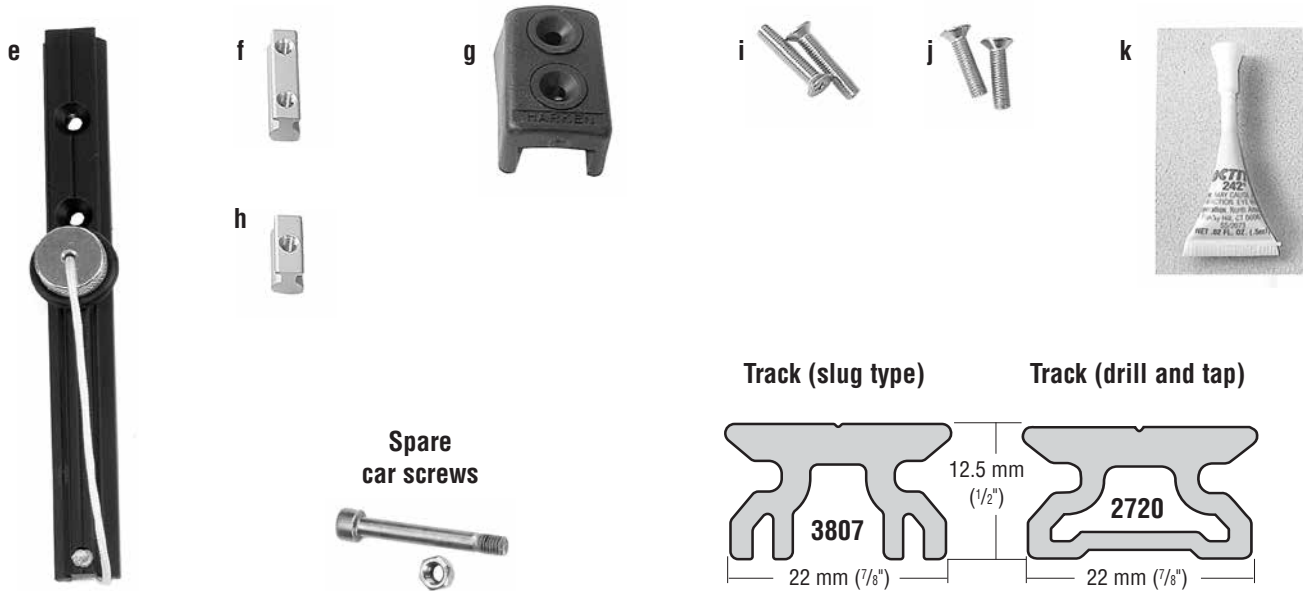

Track and Accessories

Part No.	Description	Includes
Mounting Slug Method		
3804, 3805 3806	Track mounting kit	(a) 15 mounting slugs 19 mm (3/4"); (b) 1 connector slug 67 mm (2 5/8"); (c) 2 tubes blue Loctite® adhesive; (d) 17 HFS1015 flathead screws 5 x 20 mm
3824, 3825 3826	Screwpin endstop kt	(e) 1 end track with screwpin stop; (f) 1 top stop slug 32 mm (1 1/4"); (g) 1 top endstop 263A; (h) 1 mounting slug 19 mm (3/4"); (i) 2 HFS320 flathead screws 5 x 25 mm; (j) 2 HFS1015 flathead screws 5 x 20 mm; (k) 1 tube blue Loctite® adhesive
3808, 3809 3810	Endstop kit	(g) 2 endstops 263A; (i) 4 HFS320 flathead screws 5 x 25 mm; (f) 2 stop slugs 32 mm (1 1/4")
3807	Track	Section length: 2.05 m (6'8 7/8"). Number of track sections will vary according to luff length of your mainsail.
Drill & Tap Method		
2720	Track	Use for masts without grooves or when slugs will not fit. Purchase stainless steel #10 (5 mm) screws separately. Do not use 3807 open-backed track. It requires mounting slugs. See page 8 for drill/tap sizes and mounting instructions.

Loctite is a registered trademark of Henkel AG & Company KGaA.

Tools You Will Need

1. Tape measure	10. Putty knife
2. Tape	11. Hex wrench (4 mm)
3. Power drill (screwdriver)	12. Nut driver (8 mm) or open wrench
4. Drill bit 5.5 mm (13/64")	Drill & Tap (additional)
5. Phillips screwdriver	13. Spring clamp
6. Hammer	14. Spring-loaded center punch (not shown)
7. Hacksaw	15. Drill bit 4.2 mm (5/32") (not shown)
8. Center punch	16. Tap 5 x .80 mm (10-32) (not shown)
9. File	17. Transfer punch (5.2 mm or .205")



Mast-Up Installation: Stepladder secured to the boat.

Work Height: 2.13 m (7') above boom

Sizing

Make sure that you have the correct size Battcar system for your boat.

Car part numbers			Car type	Maximum sail area			
Headboard	Battcars	Intermediate		Monohull	Multihull		
3811	3829, 3830	3812, 3831	CB	600 ft ²	56 m ²	500 ft ²	46 m ²
3827	3802, 3803	3828	Slider	600 ft ²	56 m ²	500 ft ²	46 m ²
—	—	1777	Slider	350 ft ²	33 m ²	300 ft ²	28 m ²

Sail Modifications (See page 12)

- Mainsail headboard
 - Drill new halyard location
 - Drill attachment to accept clevis pin for 3811/3827 headboard car coupler.
- Batten receptacle on sail to accept 10 mm threaded stud.
Note: Harken does not supply receptacle.
- Becket spacer on sail for 1777, 3812, 3828, or 3831 intermediate cars.

Determine Track Length

Measure track length from point 1 to point 2. See diagram at left. Use this measurement in two charts to follow.







- Upper end:** 203 mm (8") above black band. Track is longer than sail luff length to allow for stretch as sail ages. Track *must not* block halyard exit.
- Lower end:** Bottom of track will be approximately 10 mm (3/8") above gooseneck fitting. When installed 3824, 3825, 3826 endstop kit track should be as low as possible yet you should still be able to install long headboard cars. Test measurement by using long headboard car. See photo at right.

3808, 3809, 3810 Endstop kit: Cut a 203 mm (8") piece from finished end of one of the 2.05 m (6'8 7/8") 3807 tracks. You will remove this track when loading cars so it can be lower on mast. See page 7, step 11. Drill lower hole for stop. See page 5, step 3.

Number of Track Sections

Bottom 203 mm (8") endstop track and variable length top track included in measurements below. See example below:

Track Length	Number of 2.05 m (6'8 7/8) Track Sections
8.458 m to 10.490 m (27'9" to 34'5")	5
10.516 m to 12.522 m (34'6" to 41'1")	6
12.548 m to 14.580 m (41'2" to 47'10")	7
14.605 m to 16.637 m (47'11" to 54'7")	8
16.662 m to 18.694 m (54'8" to 61'4")	9

Track length example	
	2.05 m (6'8 7/8")
	2.05 m (6'8 7/8")
	2.05 m (6'8 7/8")
	2.05 m (6'8 7/8")
	2.05 m (6'8 7/8")
	.203 m (8")
Total	10.49 m (34'5")

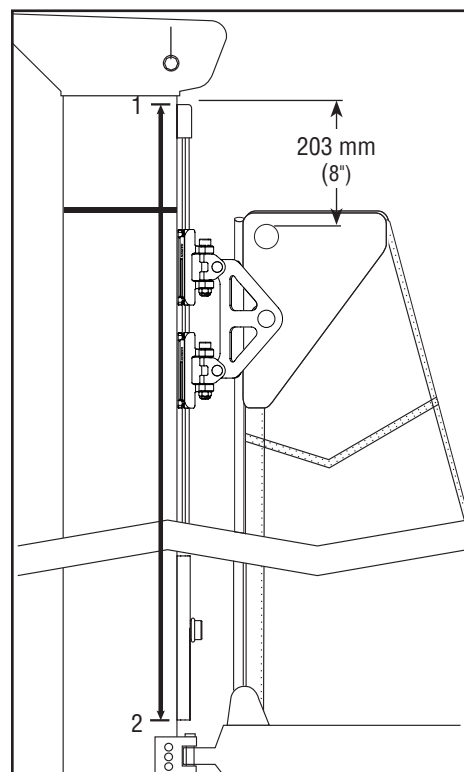

Top track length chart: (use for 3807 slug mount track). Round track length to nearest 25 mm (1").

Note: Chart is based on using 8" (203 mm) end track at bottom.

Total Track Length (as defined on page 3)								Top Track Length			
27' 9"	8.458 m	—	—	41' 2"	12.548 m	47' 11"	14.605 m	54' 8"	16.662 m	1 ⁵ / ₁₆ "	41 mm
27' 10"	8.484 m	34' 6"	10.516 m	41' 3"	12.573 m	48' 0"	14.630 m	54' 9"	16.688 m	2 ¹ / ₁₆ "	52 mm
27' 11"	8.509 m	34' 7"	10.541 m	41' 4"	12.598 m	48' 1"	14.656 m	54' 10"	16.713 m	3"	76 mm
28' 1"	8.560 m	34' 9"	10.592 m	41' 6"	12.649 m	48' 3"	14.707 m	55' 0"	16.764 m	5"	127 mm
28' 3"	8.611 m	34' 11"	10.643 m	41' 8"	12.700 m	48' 5"	14.757 m	55' 2"	16.815 m	7"	178 mm
28' 5"	8.661 m	35' 1"	10.693 m	41' 10"	12.751 m	48' 7"	14.808 m	55' 4"	16.866 m	9"	229 mm
28' 7"	8.712 m	35' 3"	10.744 m	42' 0"	12.802 m	48' 9"	14.859 m	55' 6"	16.916 m	11"	279 mm
28' 9"	8.763 m	35' 5"	10.795 m	42' 2"	12.852 m	48' 11"	14.910 m	55' 8"	16.967 m	1' 1"	330 mm
28' 11"	8.814 m	35' 7"	10.846 m	42' 4"	12.903 m	49' 1"	14.961 m	55' 10"	17.018 m	1' 3"	381 mm
29' 1"	8.865 m	35' 9"	10.897 m	42' 6"	12.954 m	49' 3"	15.011 m	56' 0"	17.069 m	1' 5"	432 mm
29' 3"	8.915 m	35' 11"	10.947 m	42' 8"	13.005 m	49' 5"	15.062 m	56' 2"	17.120 m	1' 7"	483 mm
29' 5"	8.966 m	36' 1"	10.998 m	42' 10"	13.056 m	49' 7"	15.113 m	56' 4"	17.170 m	1' 9"	533 mm
29' 7"	9.017 m	36' 3"	11.049 m	43' 0"	13.106 m	49' 9"	15.164 m	56' 6"	17.221 m	1' 11"	584 mm
29' 9"	9.068 m	36' 5"	11.100 m	43' 2"	13.157 m	49' 11"	15.215 m	56' 8"	17.272 m	2' 1"	635 mm
29' 11"	9.119 m	36' 7"	11.151 m	43' 4"	13.208 m	50' 1"	15.265 m	56' 10"	17.323 m	2' 3"	686 mm
30' 1"	9.169 m	36' 9"	11.201 m	43' 6"	13.259 m	50' 3"	15.316 m	57' 0"	17.374 m	2' 5"	737 mm
30' 3"	9.220 m	36' 11"	11.252 m	43' 8"	13.310 m	50' 5"	15.367 m	57' 2"	17.424 m	2' 7"	787 mm
30' 5"	9.271 m	37' 1"	11.303 m	43' 10"	13.360 m	50' 7"	15.418 m	57' 4"	17.475 m	2' 9"	838 mm
30' 7"	9.322 m	37' 3"	11.354 m	44' 0"	13.411 m	50' 9"	15.469 m	57' 6"	17.526 m	2' 11"	889 mm
30' 9"	9.373 m	37' 5"	11.405 m	44' 2"	13.462 m	50' 11"	15.519 m	57' 8"	17.577 m	3' 1"	940 mm
30' 11"	9.423 m	37' 7"	11.455 m	44' 4"	13.513 m	51' 1"	15.570 m	57' 10"	17.628 m	3' 3"	991 mm
31' 1"	9.474 m	37' 9"	11.506 m	44' 6"	13.564 m	51' 3"	15.621 m	58' 0"	17.678 m	3' 5"	1.041 m
31' 3"	9.525 m	37' 11"	11.557 m	44' 8"	13.614 m	51' 5"	15.672 m	58' 2"	17.729 m	3' 7"	1.092 m
31' 5"	9.576 m	38' 1"	11.608 m	44' 10"	13.665 m	51' 7"	15.723 m	58' 4"	17.780 m	3' 9"	1.143 m
31' 7"	9.627 m	38' 3"	11.659 m	45' 0"	13.716 m	51' 9"	15.773 m	58' 6"	17.831 m	3' 11"	1.194 m
31' 9"	9.677 m	38' 5"	11.709 m	45' 2"	13.767 m	51' 11"	15.824 m	58' 8"	17.882 m	4' 1"	1.245 m
31' 11"	9.728 m	38' 7"	11.760 m	45' 4"	13.818 m	52' 1"	15.875 m	58' 10"	17.932 m	4' 3"	1.295 m
32' 1"	9.779 m	38' 9"	11.811 m	45' 6"	13.868 m	52' 3"	15.926 m	59' 0"	17.983 m	4' 5"	1.346 m
32' 3"	9.830 m	38' 11"	11.862 m	45' 8"	13.919 m	52' 5"	15.977 m	59' 2"	18.034 m	4' 7"	1.397 m
32' 5"	9.881 m	39' 1"	11.913 m	45' 10"	13.970 m	52' 7"	16.027 m	59' 4"	18.085 m	4' 9"	1.448 m
32' 7"	9.931 m	39' 3"	11.963 m	46' 0"	14.021 m	52' 9"	16.078 m	59' 6"	18.136 m	4' 11"	1.499 m
32' 9"	9.982 m	39' 5"	12.014 m	46' 2"	14.072 m	52' 11"	16.129 m	59' 8"	18.186 m	5' 1"	1.549 m
32' 11"	10.033 m	39' 7"	12.065 m	46' 4"	14.122 m	53' 1"	16.180 m	59' 10"	18.237 m	5' 3"	1.600 m
33' 1"	10.084 m	39' 9"	12.116 m	46' 6"	14.173 m	53' 3"	16.231 m	60' 0"	18.288 m	5' 5"	1.651 m
33' 3"	10.135 m	39' 11"	12.167 m	46' 8"	14.224 m	53' 5"	16.281 m	60' 2"	18.339 m	5' 7"	1.702 m
33' 5"	10.185 m	40' 1"	12.217 m	46' 10"	14.275 m	53' 7"	16.332 m	60' 4"	18.390 m	5' 9"	1.753 m
33' 7"	10.236 m	40' 3"	12.268 m	47' 0"	14.326 m	53' 9"	16.383 m	60' 6"	18.440 m	5' 11"	1.803 m
33' 9"	10.287 m	40' 5"	12.319 m	47' 2"	14.376 m	53' 11"	16.434 m	60' 8"	18.491 m	6' 1"	1.854 m
33' 11"	10.338 m	40' 7"	12.370 m	47' 4"	14.427 m	54' 1"	16.485 m	60' 10"	18.542 m	6' 3"	1.905 m
34' 1"	10.389 m	40' 9"	12.421 m	47' 6"	14.478 m	54' 3"	16.535 m	61' 0"	18.593 m	6' 5"	1.956 m
34' 3"	10.439 m	40' 11"	12.471 m	47' 8"	14.529 m	54' 5"	16.586 m	61' 2"	18.644 m	6' 7"	2.007 m
34' 5"	10.490 m	41' 1"	12.522 m	47' 10"	14.580 m	54' 7"	16.637 m	61' 4"	18.694 m	6' 8 ¹ / ₈ "	2.054 m

1. Cut special length top track from 2.05 m (6'8 3/4") track.

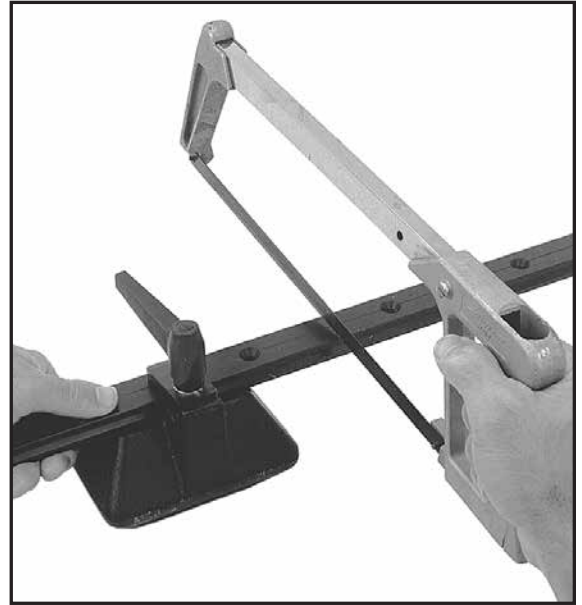

2. Deburr cut.

Slightly round track corners that will slide against mast.



3. Drill two 5.5 mm (13/64") holes in cut end of track.
Center at 8 mm (5/16") and 27 mm (11/16").

Short top track lengths

41 mm (1 5/16")	Use existing hole. Do not drill second hole.
52 mm (2 1/16")	Use existing hole, drill hole 5/16" (8 mm) from cut end.

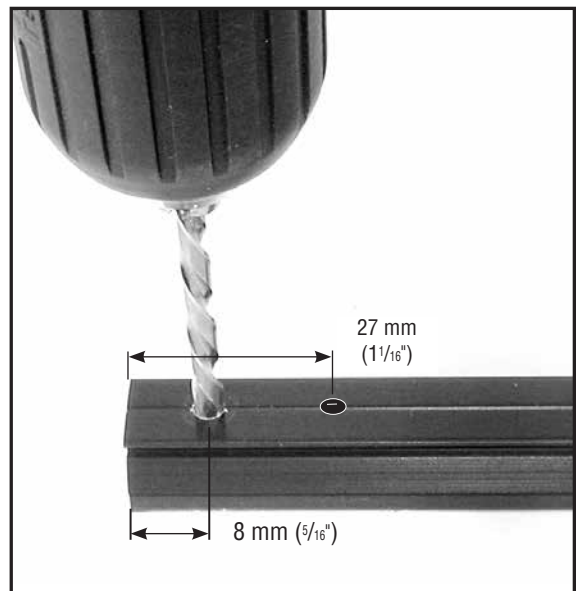

CB/Slider Systems (Slug Mount)

67 mm (2 5/8") connector slug must fit feeder opening.
File opening to make longer.

Use halyard with retrieval line to hoist 67 mm (2 5/8") connector slug up mast to check for burrs in groove.

Mast prebend: May require straightening before installation.

Storm Trysail Track

Cars must clear storm trysail track. Tracks often converge above spreaders.

Aft face of mast must be flat or convex.

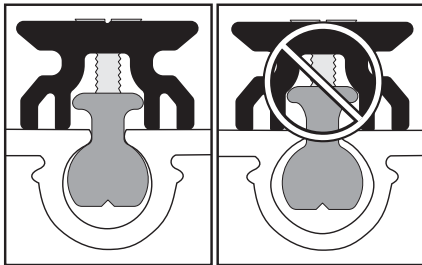

Test track: Put mounting slug in groove, track section on mast. Tighten with screw. Track must be drawn tightly to mast.

Mounting screw must be long enough for mast groove.
If necessary, purchase longer screws.

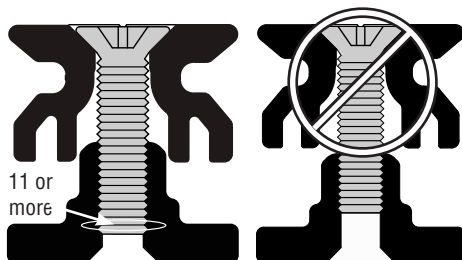

Warning! Screws need minimum of 5 threads (turns) engaged to hold track to mast. Turn screw 360° five times after threads engage slug.

Check Fit of Mounting Slugs/Car

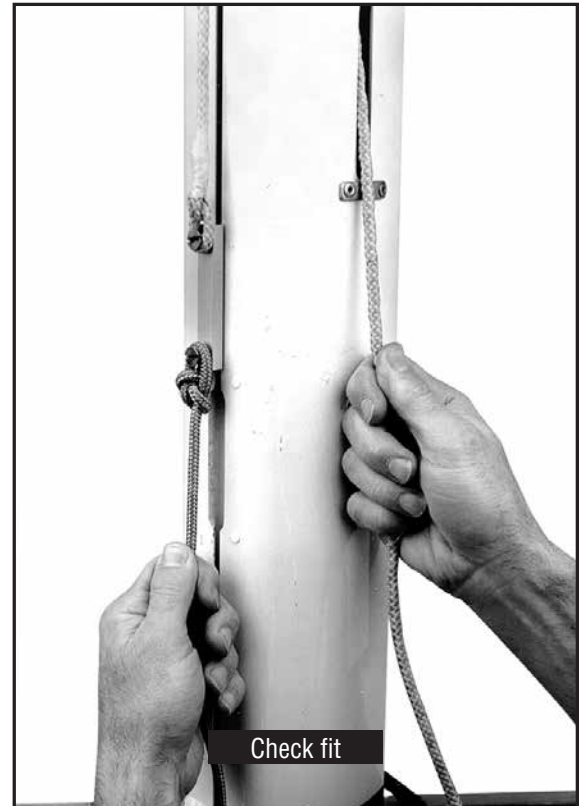

1. Slip top track slugs into mast groove. Use 32 mm (1 1/4") mounting slug for top stop.

Short top track lengths	Top slug
41 mm (1 5/16")	67 mm (2 5/8")
52 mm (2 1/16")	19 mm (3/4")

Mast up: Tape 32 mm (1 1/4") slug even with top of upper track. Tape other slugs in place.

2. One drop blue Loctite® adhesive into each connector slug hole.

3. Thread 5 mm x 25 mm endstop screws through endstop, track, and into endstop slug.

Short top track lengths	
41 mm (1 5/16")	Use one screw in stop
52 mm (2 1/16")	Use both screws

Mast up: Remove tape. Tighten screw to hold track.



4. Slide slugs into place with putty knife.
Loosely install 5 mm x 20 mm screws.

Tip: Use putty knife to see if screws are loose enough to slide in groove.

Remember: Tracks may stick when reaching a spliced area on mast.

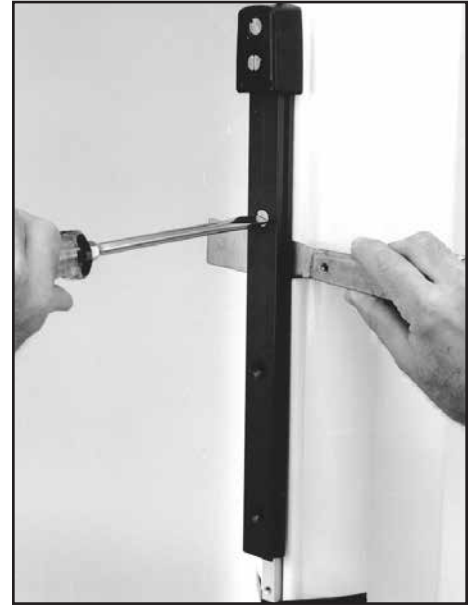

5. Loosen top screw. Slide top track up and position next 2.05 m (6'8 3/4") track.

Mast up: Tighten bottom screw to hold track.



6. Slide 15 mounting slugs and then the connector slug into mast groove.

Mast up: Tape in place.

One drop blue Loctite® adhesive into each hole.



7. Hold full-length track piece up to mast. Loosely install top screw.

Use putty knife to slide additional slugs and connector slug into place. Loosely install all fifteen 5 mm x 20 mm screws.

8. Slide tracks up enough to fit next track.

Mast up: Hold upper tracks. Loosen screw that holds tracks. Slide track up. If screws bind in mast groove opening, loosen them until track slides. Tighten new bottom screw securely.



CAUTION! Do not let tracks drop. Severe injury to hands and/or fingers can result.

9. Repeat until full-length tracks installed.



10. Raise tracks so 203 mm (8") bottom track fits.

11. Install screwpin endstop kit.

3808, 3809, 3810 Endstop Kit
Leave bottom 203 mm (8") track off until cars are installed.

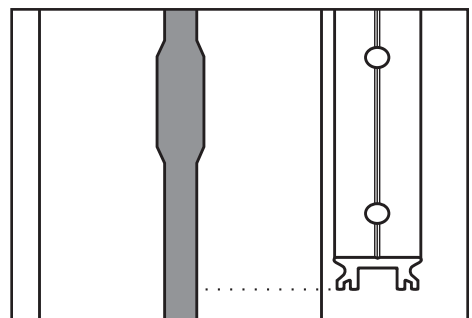

Note: If bottom full-length track blocks feeder gap, load bottom track slugs before installing track.

Track and Accessories

Part No.	Description	Includes
Purchase from Harken		
2707	Track (Micro CB)	Use for masts without grooves or when slugs will not fit. Purchase stainless steel #8 (4 mm) screws separately. Do not use 3817 open-backed track. It requires mounting slugs. See page 11 for drill/tap sizes and mounting instructions.
2724	Splice links	One needed for each track joint
263	Endstop set	
Purchase Separately		
#10 (5 mm) Flathead screws		Purchase 10 fasteners/meter of track
Drill		4.2 mm (5/32")
Tap		10-32 (5 x .80 mm)



Determining Track Length

Bottom track must be short enough to remove easily. Use 457 mm to 609 mm (18" to 24") length. **Do not use 3807 track for drilling and tapping.**

Remove Old Track

IMPORTANT! Before removing old track, scribe pencil line down either side.

Drill, Tap, and Fasten

After old track is removed, attach string to mast to line up track during installation.

1. Start at one end of track and work down: Do not drill and tap from both track ends.

Clamp or duct tape track on mast. Center punch in center of track hole using a narrow shaft spring-loaded machinist's punch with plastic centering tube or a transfer punch. Track hole size is 2.05" or 5.2 mm.

2. Drill track hole, holding drill perpendicular to mast face. Tap threads and install screws using blue Loctite® adhesive.

Tip: Use low speed drill with tap for cutting threads.

IMPORTANT! Use blue Loctite® adhesive instead of oil for tapping lubricant.

3. Align track at joints. Use 2711 splice links and round rods or dowels on outside of track to align during installation. Hold in place with spring or "C" clamps until track is secured.

Load all cars before installing bottom track and endstop.

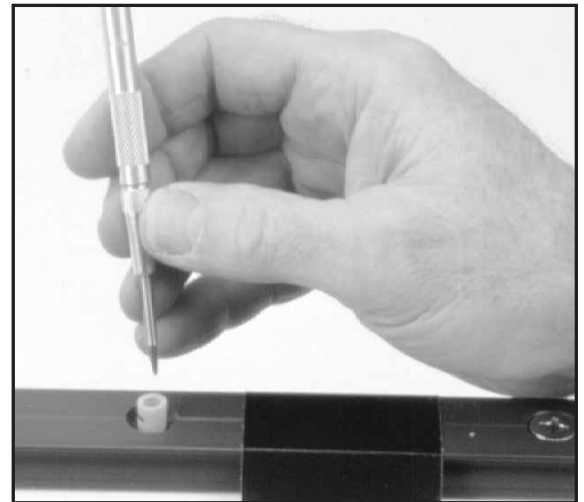

Loctite is a registered trademark of Henkel AG & Company KGaA.

IMPORTANT! To keep balls captive we recommend loading cars onto track without sail installed.
 Chart below shows correct number of balls for each car.

1. **Headboard cars:** Hold car so cap screw head faces up. Align car on guide section of loader track and gently roll onto upper tracks. If car sticks, realign and roll onto track.

Tip: To load headboard car assembly, angle headboard coupler, roll car onto track. If necessary, remove headboard assembly.



2. Load intermediate car (if used). Alternate with batten cars until all cars are loaded.

Mast up: Use halyard to hold cars up.



3. Install screwpin stop.

**3808, 3809, 3810
 Endstop kit**
 Remove bottom 203 mm (8")
 track and install cars.

*Tip: Use halyard to hold
 tracks up.*



CB System

Cars with sail attached can be loaded by carefully aligning car with track and supporting sail to keep weight off cars.

Line up car on guide portion of loader. Press car toward mast and carefully roll car onto track. Begin with upper cars and work down.

Load Cars on Track with Sail Attached

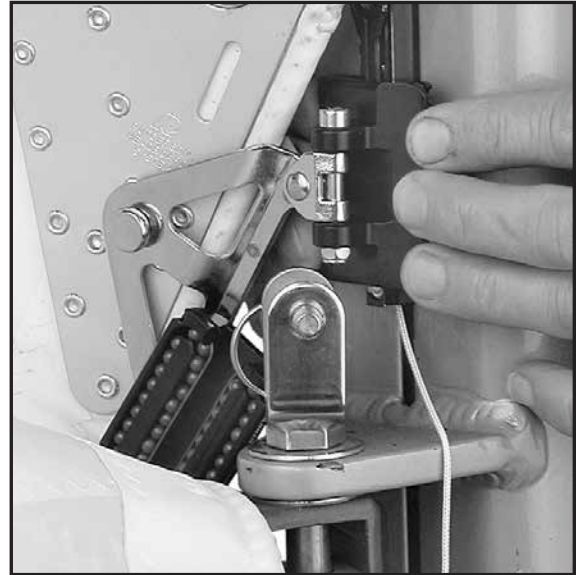

Tip: Have another person help hold sail while you load cars.

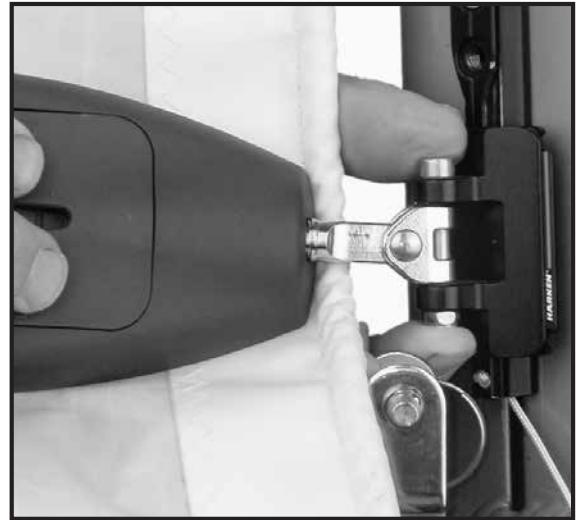

CB System

Consult chart for ball type: Torlon® or Delrin® ball bearings. Place car on edge with retaining clip in place. Insert balls one-by-one from center of clip and roll into return race. **Do not overfill car.**

Lost Balls



Part No.	Car Type	Car Length		Bearings		Number per Car	Purchase Part No.	Balls/Set	Ball Ø	
		in	mm	Color	Material				in	mm
3811	Headboard cars (2)	8 ³ / ₈	213	Brown	Torlon	60	177	21	1/4	6
3812	Intermediate car	2 ¹ / ₄	57	Brown	Torlon	32	177	21	1/4	6
3829	Batten car w/threaded stud	2 ⁷ / ₈	73	Brown	Torlon	40	177	21	1/4	6
3830	Battcar w/40 mm receptacle	2 ⁷ / ₈	73	Brown	Torlon	40	177	21	1/4	6
3831	Universal car	2 ⁷ / ₈	73	Brown	Torlon	40	177	21	1/4	6
3881	Batten car w/12 mm threaded stud	2 ⁷ / ₈	73	Brown	Torlon	40	177	21	1/4	6
3882	Batten car w/12 mm threaded stud	4 ¹ / ₈	105	Brown	Torlon	60	177	21	1/4	6
3883	Reef car	4 ¹ / ₈	105	Brown	Torlon	60	177	21	1/4	6

Delrin is a registered trademark of E. I. du Pont de Nemours and Company or its affiliates.
Torlon is a registered trademark of Solvay Advanced Polymers.

Slider System

Slider cars can be loaded onto tracks with or without sail attached.

Line up car on guide portion of loader. Press car toward mast and slide car onto track. Begin with upper cars and work down.

Tip: To load headboard car assembly, angle headboard. Roll car onto tracks. If necessary, remove headboard assembly.

Load Cars on Track with Sail Attached

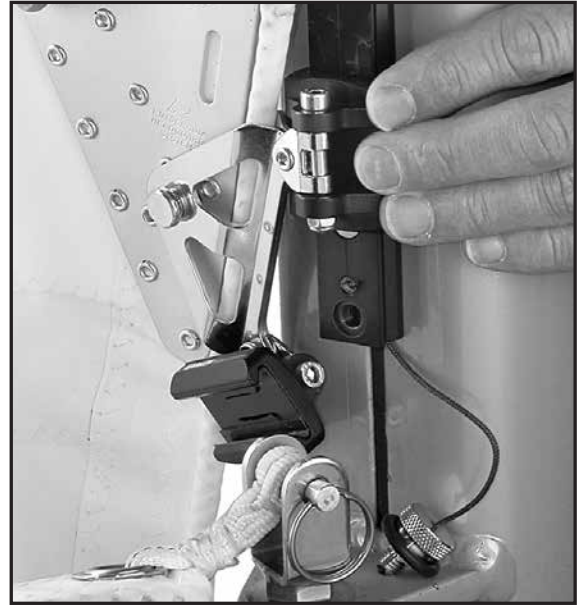

3883 Reef Car

1. Beginning with lower cars, use 4 mm hex key and 8 mm wrench or nut driver to attach sail to cars. Tighten lock nut until bottom tip of fastener is flush with nut.

For 3883 reef car, line up plastic becket spacer and insert clevis pin.



Load Sail on Cars



2. Screw threaded stud to sail batten receptacle. Thread completely in and then back off two turns. Receptacle must be allowed to rotate on stud.



3. Load toggle using 4 mm hex key and 8 mm wrench or nut driver. Tighten lock nut. **Do not over tighten.** Make sure toggle can pivot.



3a. For 3881 and 3882 battcars, line up toggle and insert clevis pin.



4. Attach head of sail to headboard car with clevis pin and cotter pin.

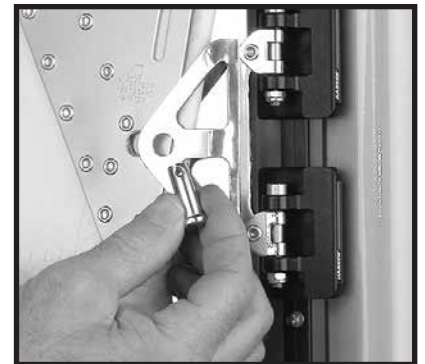

4a. For 3881 and 3882 battcars, press quick release button and push up on bottom of pin. Remove clevis pin.



Removing Sail (CB System)

From cars: Remove clevis pin from head of sail. Use a 4 mm hex wrench and a 8 mm wrench or nut driver on other cars.

Cars and sail: Keep cars lined up with track when sliding off.

Inspect cars: 20 balls per side. Replace 5 mm locknut after two removals.

Removing Sail (Slider System)

If your system has slider Battcars without ball bearings, leave slides attached and slide cars off, beginning at the bottom.

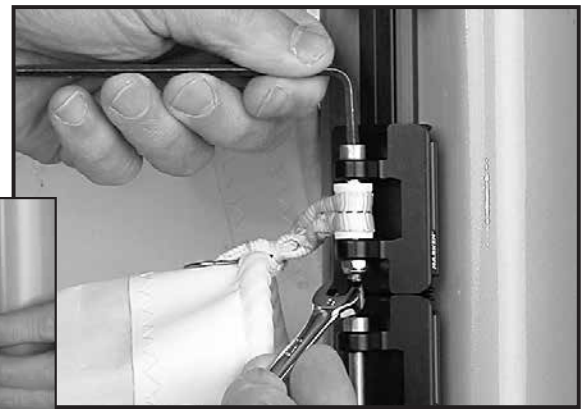

Car Maintenance/Cleaning (CB System)

Clean beginning of season, or if cars bind. Squirt detergent and water into ball bearings. Circulate by moving cars up and down. Let stand. To remove detergent, spray water into ball bearings and circulate. Clean tracks with detergent and water.

Use OneDrop™ Ball Conditioner (CB System)

Once dry, use *only* a single drop of McLube® OneDrop™ ball bearing conditioner. Do not use spray lubricants because ball bearings may skid not roll. Apply one to two drops of McLube OneDrop to ball contact surfaces of track. Roll car back and forth through OneDrop several times to distribute onto bearings. Wipe remaining OneDrop off track. OneDrop is preferred, but you can also use one to two drops of a light machine oil. Too much attracts dirt.

McLube is a registered trademark of McGee Industries, Inc.

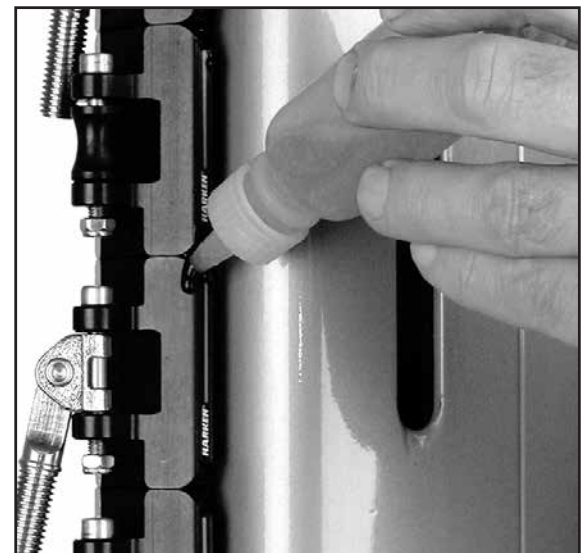

Inspect

Inspect Battcars for loose locknuts. Replace. Inspect batten receptacles for loose screws.

CB/Slider Systems

Lazy Jacks

Use shockcord to hold Lazy Jacks open so Battcars and battens will not catch on them when hoisting sail. This will also help stop Lazy Jacks from slapping on sail. Attach one end to lower spreader tips and the other to Lazy Jacks. Make sure shockcord is long enough so boom can swing out all the way without damaging spreaders.

Operating Precautions

When lowering sail, do not let halyard go. Ease cars down by keeping a wrap on winch.

IMPORTANT! On unstayed masts, avoid over-rotation of sail.

On boats with unstayed masts, vang must be used to prevent over-rotation of upper part of sail. Over-rotation can damage batten receptacles.

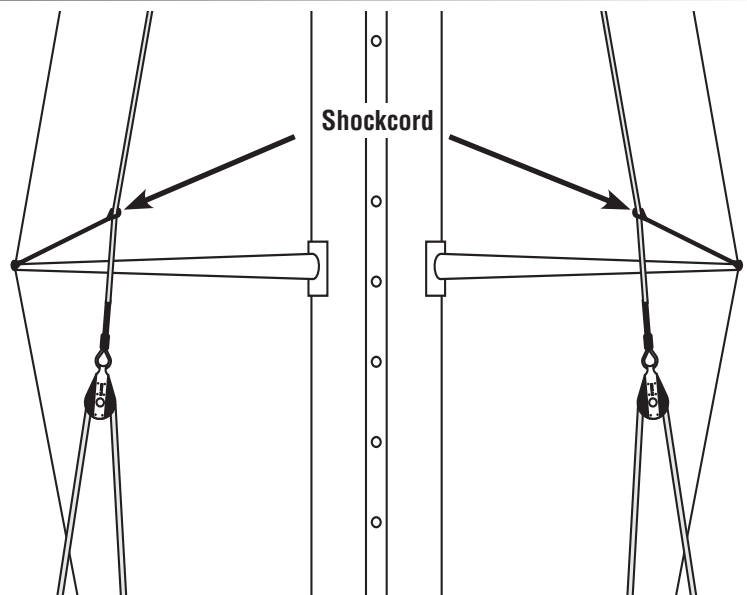

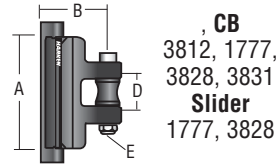
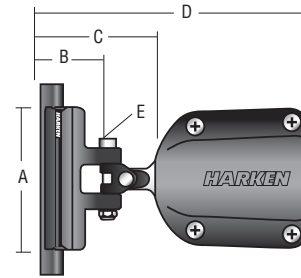
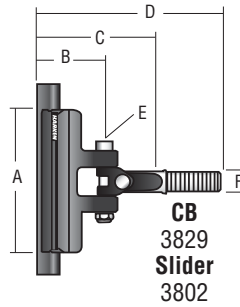
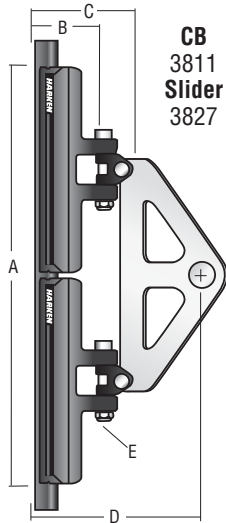

Dimensions (measured from aft face of mast)

Part No.	Description	A		B		C Boltrope setback		D		E Pin Ø		F Stud Ø
		in	mm	in	mm	in	mm	in	mm	in	mm	mm
System A CB												
3811	Headboard car assembly	8 3/8	213	1 3/8	35	2 1/4 / 2 1/8 *	57 / 73 *	4	102	3/16	5	—
3812	Intermediate car	2 1/4	57	1 3/8	35	—	—	3/4	19	3/16	5	—
3829	Battcar/10 mm stud	2 7/8	73	1 3/8	35	2 1/4	57	3 11/16	94	3/16	5	10
3830	Battcar/receptacle	2 7/8	73	1 3/8	35	2 7/8	73	5 3/4	146	3/16	5	—
3831	Universal Battcar	2 7/8	73	1 3/8	35	—	—	3/4	19	3/16	5	—
3881	Battcar/12 mm stud	2 7/8	73	1 3/8	35	2 3/4	69	3 7/8	99	1/4	6	12
3882	Long batten car/12mm stud	4 1/8	105	1 3/8	35	2 3/4	69	3 7/8	99	1/4	6	12
3883	Reef car	4 1/8	105	1 3/8	35	—	—	3/4	19	1/4	6	—
System A Slider												
3827	Headboard car assembly	6	153	1 1/16	27	2 1/8	54	3 11/16	94	3/16	5	—
1777	Intermediate car/low-load	2	51	1 1/8	28	—	—	3/4	19	3/16	5	—
3828	Intermediate car	1 3/4	44	1 1/16	27	—	—	2 1/32	17	3/16	5	—
3802	Battcar/10 mm stud	1 3/4	44	1 1/16	27	2 1/8	54	—	—	3/16	5	10
3803	Battcar/receptacle	1 3/4	44	1 1/16	27	2 1/8	54	5 1/8	130	3/16	5	—

CB/Slider Systems

Installing Headboard Car Assembly

Headboard coupler attaches to standard headboards - some headboard modification required.

Maximum thickness of headboard plates and sail: 14 mm (9/16")

G Center of coupler attachment hole to front edge of boltrope	
3802	40 mm (1 9/16")
3830	30 mm (1 3/16")
3829	44 mm (1 3/4")
3803	43 mm (1 11/16")

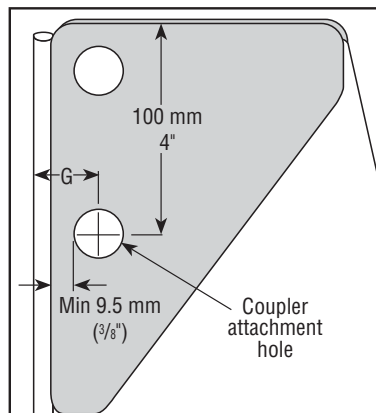

Coupler Attachment Hole

Drill 11 mm (7/16") coupler attachment hole so center is 101 mm (4") from top of headboard. Consult chart to determine "G" based on Battcar used.

Leave at least 9 mm (3/8") between front of headboard plate and front edge of coupler attachment hole.

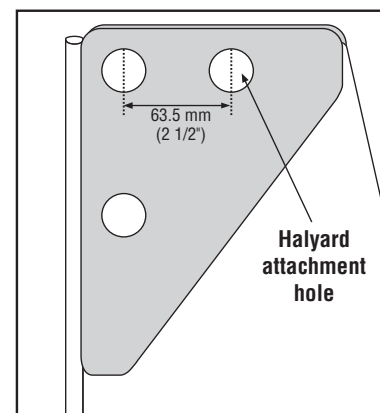

Halyard Attachment Hole

Use aft hole if headboard has two.

If not, drill second hole to accept halyard shackle pin. Locate hole approximately 63.5 mm (2 1/2") aft of existing hole.

Option 1

Round battens

End batten pocket 254 mm (10") from receptacle.

Flat battens

End batten pocket 254 mm (10") from receptacle.



Option 2

Round battens

Pucker batten pocket; draw edges together before inserting batten.

Flat battens

Fit batten into receptacle. If necessary, pucker batten pocket and draw edges together before inserting. May require optional shim.

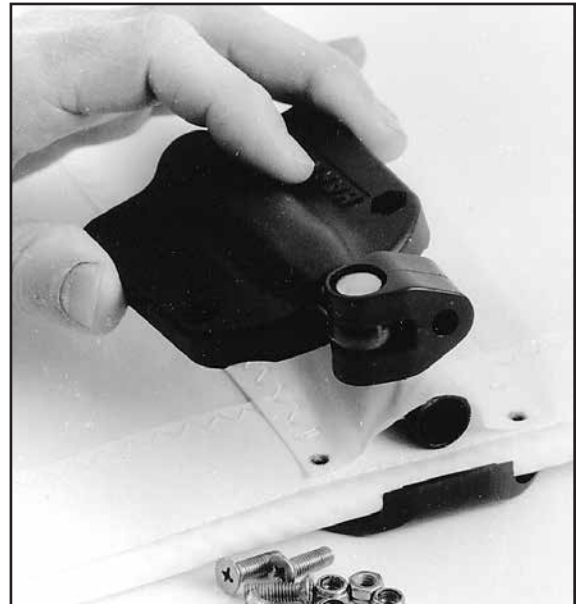

Optional Shim

Use enclosed rubber shim so thin flat battens or small diameter round battens fit correctly inside receptacle. To insert shim, take apart batten receptacle with batten inside. Place rubber shim on one side of the batten. Assemble. **Note: screw and nuts are not captive.**



Assembly

Place batten receptacles on same side of sail. Make sure front of coverplate presses on swivel pin retainer that secures swivel pin. Tighten screws and nuts.

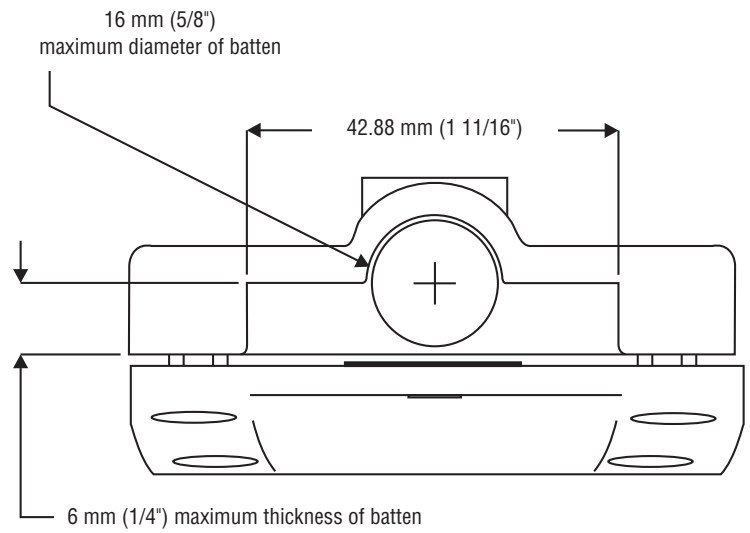

CB/Slider Systems

Distance Between Attachment Points

Battens and intermediate cars placed at sailmaker's discretion. Maximum distance between attachment points is 1.2 m to 1.35 m (4' to 4'6").

Distance may be slightly greater. Contact Harken to discuss sail reshaping to eliminate luff flutter.

Note: Adding battens may reduce stack height by eliminating luff cars.

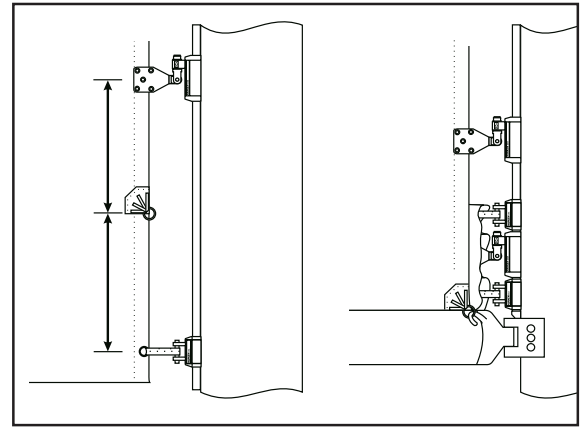

Diagram A

Setting Reef Points

Space reef points halfway between sail attachment points. Battens or reef points may need to be moved. Diagram A.

Note: Batten fittings and cars cannot handle reefing outhaul or downhaul loads. Transfer loads to a tack fitting. Diagram B.

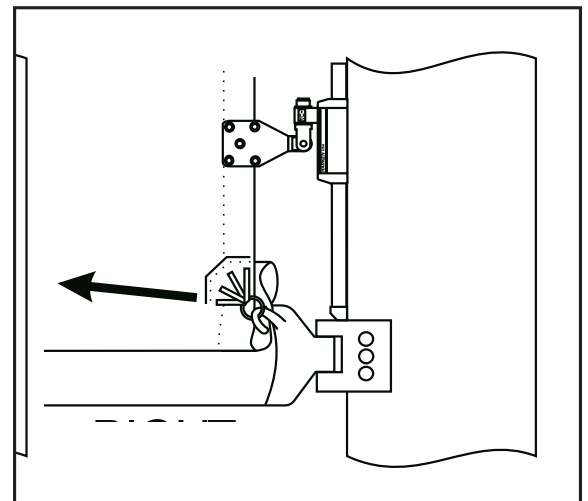
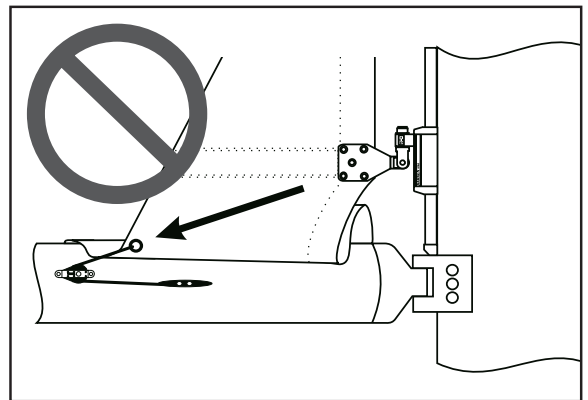
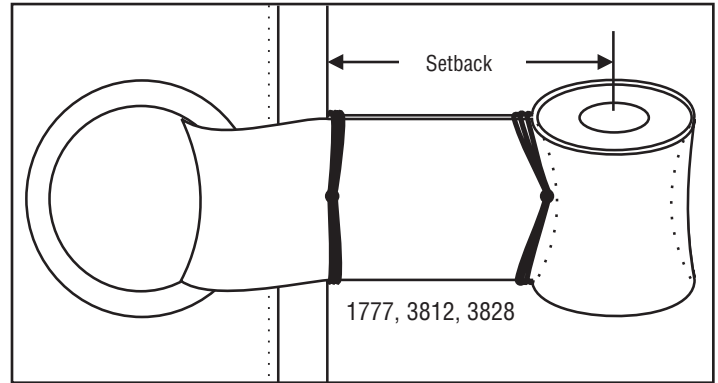

Diagram B

Sail setback from luff tape to intermediate car clevis pin will vary depending upon intermediate and batten car.

Intermediate Cars	Batten Cars		
	3802/3803 Slider cars	3829 CB Cars w/10 mm stud	3830 CB car w/batten recpt.
Setback – Luff tape to pin			
1777	26 mm (1")	30 mm (1 ³ / ₁₆ "	44 mm (1 ³ / ₄ "
3812	—	23 mm (7/ ₈ "	37 mm (1 ⁷ / ₁₆ "
3828	27 mm (1 ¹ / ₁₆ "	30 mm (1 ³ / ₁₆ "	44 mm (1 ³ / ₄ "



Plastic spacers come with 1777, 3812, and 3828 intermediate cars. Seize spacer to webbing by stitching just behind plastic spacer. Seize webbing to sail by stitching up against sail.

Problem	Probable Cause	Solution
Tracks do not butt up against each other.	Cut end of top or bottom track is at joint.	Make sure the anodized end is toward the full-length track.
	Track weight pulling tracks apart.	Tracks will come together when you loosen the bottom screw and push the tracks up the mast.
Mounting slugs do not fit.	Slugs wrong size.	Different size slug required. Contact your dealer.
Mounting screws will not tighten.	Incorrect mounting slug used.	Different size slug required. Contact your dealer.
Track will not slide up mast.	Slugs catching on mast splice.	Loosen screws slightly. If necessary have someone at splice area to wiggle the slug past the splice.
	Corners of cut track catching.	Use file to round off corners of track.
	Mast has too much prebend.	Ease backstay and/or straighten mast.
	Paint or other material clogging mast groove.	Clean out groove.
CB/slider cars do not fit on track.	Track and cars are not the same size.	Contact your dealer or Harken.
CB cars do not fit on track.	Balls are missing.	Remove cars, load balls and slide cars back on track.
Sail headboard does not fit inside coupler.	Ring was not pressed far enough.	Take sail to sailmaker.

CB/Slider Systems

Operation Troubleshooting

Problem	Probable Cause	Solution
Cars bind.	Dirt in cars.	Use detergent and fresh water to flush dirt out of cars; move cars up/down to circulate; follow with high-pressure water; clean track grooves. Condition balls using McLube One-Drop. See below.
	Stud threaded too tightly into receptacle.	Back off threaded stud two turns.
	Balls missing from car.	Remove cars, load balls and slide cars back on track.
Mounting screws will not tighten.	Incorrect mounting slug used.	Get new 6 mm lock nut.
Batten receptacle does not rotate.	Nuts are too tight.	Loosen nuts slightly.
Cars jam when raising sail.	Headboard or cars are catching on lazy jacks.	Use topping lift or rod vang and shock cord to pull lazy jacks out to shrouds.
Sail will not go all the way up.	Sail is too tall or sheave is too far forward.	Have sail shortened or move sheave aft.
Vertical post or pin on batten receptacle bending.	Reef loads are being transferred to batten receptacle.	Transfer reef downhaul and outhaul loads to mast or boom gooseneck.
Reef tack fitting will not reach reef hook.	Reef point too close to sail attachment.	Move intermediate car sail attachment.

Maintenance

Clean beginning of season, or if cars bind. Squirt detergent and water into ball bearings. Circulate by moving cars up and down. Let stand. To remove detergent, spray water into ball bearings and circulate. Clean tracks with detergent and water.

Do not use spray lubricants because ball bearings may skid, not roll. Once cars and tracks are dry, apply one to two drops of McLube® OneDrop™ conditioner to ball contact surfaces of track. Roll car back and forth through OneDrop several times to distribute onto bearings. Wipe remaining OneDrop off track. OneDrop is preferred, but you can also use one to two drops of a light machine oil. Too much oil attracts dirt.



Warranty

For additional safety, maintenance, and warranty information: www.harken.com/manuals or the Harken catalog.

Loctite is a registered trademark of Henkel AG & Company KGaA.
 McLube is a registered trademark of McGee Industries, Inc.
 OneDrop is a trademark of McLube®, a Division of McGee Industries.

HARKEN®

Corporate Headquarters

N15W24983 Bluemound Rd, Pewaukee, WI 53072 USA
Telephone: (262) 691-3320 • Fax: (262) 701-5780
Web: www.harken.com • Email: harken@harken.com

Harken Australia Pty, Ltd.

1B Green Street, Brookvale, N.S.W. 2100, Australia
Telephone: (61) 2-8978-8666 • Fax: (61) 2-8978-8667
Web: harken.com.au • Email: info@harken.com.au

Harken France

ZA Port des Minimes, BP 3064, 17032 La Rochelle Cedex 1, France
Telephone: (33) 05.46.44.51.20 • Fax: (33) 05.46.44.25.70
Web: harken.fr • Email: info@harken.fr

Harken Italy S.p.A.

Via Marco Biagi, 14, 22070 Limido Comasco (CO) Italy
Telephone: (39) 031.3523511 • Fax: (39) 031.3520031
Web: harken.it • Email: info@harken.it

Harken New Zealand, Ltd.

158 Beaumont Street
Unit 11, Orams Marine Centre
Westhaven, Auckland, 1010, New Zealand
Telephone: (64) 9-303-3744 • Fax: (64) 9-307-7987
Web: harken.co.nz • Email: harken@harken.co.nz

Harken Polska SP ZOO

ul. Rydygiera 8, budynek 3A, lokal 101, I piętro, 01-793 Warszawa, Poland
Tel: +48 22 561 93 93 • Fax: +48 22 839 22 75
Web: harken.pl • Email: polska@harken.pl

Harken Sweden AB

Main Office and Harken Brandstore: Västmangatan 81B
SE-113 26 Stockholm Sweden
Telephone: (46) 0303 61875 • Fax: (46) 0303 61876
Mailing address: Harken Sweden AB, Box 64, SE -440 30 Marstrand
Web: harken.se • Email: harken@harken.se

Harken UK, Ltd.

Bearing House, Ampress Lane, Lymington, Hampshire S041 8LW, England
Telephone: (44) 01590-689122 • Fax: (44) 01590-610274
Web: harken.co.uk • Email: enquiries@harken.co.uk

Please visit: <http://www.harken.com/locator.aspx>
to locate Harken dealers and distributors