



DVN 64030 TTC Vertical decorative hood with Touch control and Rim Extraction in 60cm



LED



Perimeter extraction

DESCRIPTION

Vertical decorative hood with Touch control and Rim Extraction in 60cm

LIFE STYLE

Easy

COLOURS



REFERENCE

EAN. 8434778010565

FEATURES

Vertical decorative hood
Energy efficiency class: C
Extraction rim system "Contour"
Touch control panel
2 speeds + 1 intensive
Exhaust capacities:
Free Outlet (m³/h): 460
Max. (m³/h): 410
Min. (m³/h): 380
Noise (LwA) Max Speed 66 dB
Noise (LwA) Min Speed 65 dB
LED illumination
1 aluminium filter with 4 layers
Stop delay timer
Filter saturation indicator
Recirculation function optional Set D11CTP
Regenerative Charcoal filters optional

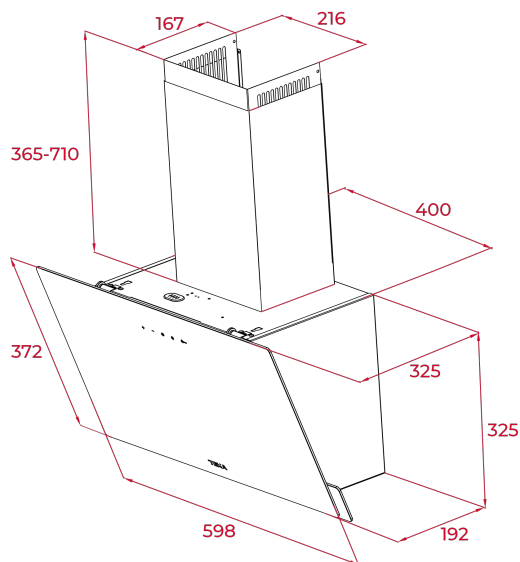

DIMENSIONS

Product height (mm): 372
Product width (mm): 598
Product depth (mm): 325
Product length (mm):
Net weight (Kg): 8,99

TECH SPECS

PARTICULAR CHARACTERISTICS

Type of hood: Vertical
Style: Decoratives
Certificates: CE; CB; EMC
Ø Outlet (mm): 150
Type of inner light: LED
Inside light Consumption (W): 1
Plug type: Schuko
Cable Connection Length (cm): 160
Power rate (V): 220-240
Frequency (Hz): 50/60
Number of motors: 2
Motor power (W): 140
Exhaust Capacity - Free Outlet (m³/h): 460

**EU REGULATION NO. 65/2014
&66/2104**

Annual energy consumption AEC kWh/annum (kWh): 60,2
Energy Efficiency Class: C
Fluid Dynamic Efficiency (FDEhood): 11,05
Fluid Dynamic Efficiency class: E
Light Efficiency (Lehood) lux/Watt: 76,1
Lighting Efficiency class: A

Grease Filtering Efficiency class: C
Air flow (Qmin) m3/h: 380
Air flow (Qmax): 410
Air flow (Qboost): 425
Noise (LwA) Min Speed (dB): 65
Noise (LwA) Max Speed (dB): 66
Noise (LwA) boost speed (dB): 67
Standby Power (Ps) W: 0,49
Time increase factor: 1,6
Electric power input at best efficiency point (Wbep) W: 101
Nominal power of the lighting system (WL) W: 2
Average illumination of the lighting system on the cooking surface (Emiddle) Lux: 152

ACCESSORIES

Anti Return valve: Yes
Outlet reduction: Yes
Optional Charcoal Filter: D9C
Charcoal filter description: CHARCOAL FILTER D9C INTEGRA (set 2 u.)
Conventional recirculation kit (with tube cover): 113290007

MODELS

Number of filters: 1
Filter description: Aluminum
Opening system: Panel Uphold Hinge
Control panel: Touch Control
Stop delay timer: Yes
Number of speeds: 2+1



DVN 64030 TTC

ENERGY LABEL

