



DSH 685 Decorative hood with Touch control display and ECOPOWER motor in 60 cm



A Energy Class



LED



Stop Delay
Timer

DESCRIPTION

Decorative hood with Touch control display and ECOPOWER motor in 60 cm

LIFE STYLE

Total

COLOURS



REFERENCE

EAN. 8421152157336

FEATURES

Double turbine armored motor EcoPower

Energy Efficiency class: A

Backlit electronic controls

Digital Display

Selected speed digital indicator

Aspiration timer

Non-Return Valve

3 speeds + intensive

Extraction capacities (*): min. 305 m³ / h – max. 735 m³ / h

Sound power (*): min. 54 dBA – max. 68dBA

LED Lighting Bar

Stainless steel decorative filters

Possibility of operation in recirculation (SET 1 / N1)

(*) Delegated Regulation (EU) No 65/2014 of the Commission of 1 October 2013.

DIMENSIONS

Product height (mm): 670-1000
Product width (mm): 600
Product depth (mm): 480
Product length (mm):
Net weight (Kg): 13,37

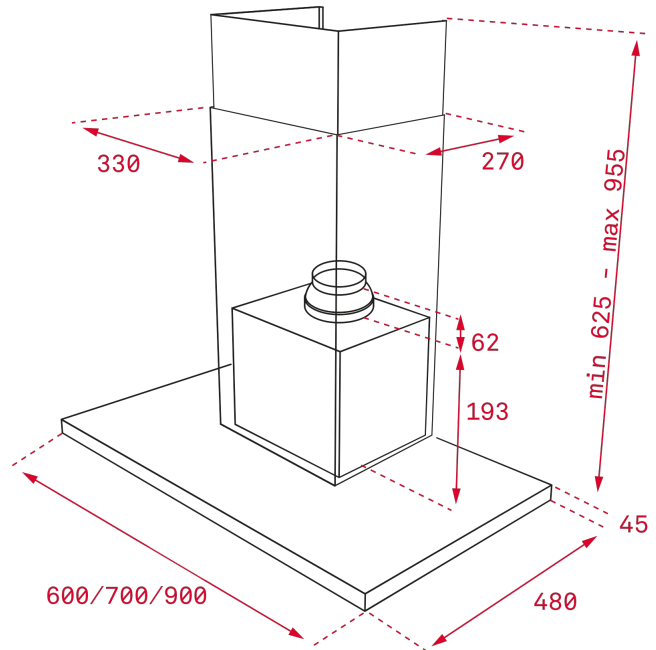

TECH SPECS

PARTICULAR CHARACTERISTICS

Type of hood: Horizontal
Style: Decoratives
Certificates: CE; CB; Rohs
Ø Outlet (mm): 150
Type of inner light: LED
Inside light Consumption (W): 6
Plug type: Schuko plug
Power rate (V): 220-240
Frequency (Hz): 50
Total hood power (W): 286
Number of motors: 1
Motor power (W): 280
Exhaust Capacity - Free Outlet (m³/h): 920

**EU REGULATION NO. 65/2014
&66/2104**

Annual energy consumption AEC kWh/annum (kWh): 54,7
Energy Efficiency Class: A
Fluid Dynamic Efficiency (FDEhood): 31,0
Fluid Dynamic Efficiency class: A
Light Efficiency (Lehood) lux/Watt: 55,2
Lighting Efficiency class: A

Grease Filtering Efficiency class: C
Air flow (Qmin) m³/h: 305
Air flow (Qmax): 586
Air flow (Qboost): 735
Noise (LwA) Min Speed (dB): 54
Noise (LwA) Max Speed (dB): 68
Noise (LwA) boost speed (dB): 72
Off mode Power (Po) W: 0,25
Energy Efficiency Index (EEI): 53,2
Time increase factor: 0,9
Electric power input at best efficiency point (Wbep) W: 153,1
Nominal power of the lighting system (WL) W: 6
Average illumination of the lighting system on the cooking surface (Emiddle) Lux: 331

ACCESSORIES

Anti Return valve: Yes
Outlet reduction: Yes
Optional Charcoal Filter: D4C
Charcoal filter description: CHARCOAL FILTER D4C
Conventional recirculation kit (with tube cover): 40490147

MODELS

Number of filters: 2
Filter description: Stainless Steel filters
Control panel: Backlit electronic control with white display
Stop delay timer: Yes
Filter saturation indicator: Yes
Number of speeds: 3+1



DSH 685

ENERGY LABEL

