



**CNL 6815 PLUS** Pull-out hood with ECOPOWER motor and 5+1 speeds in 60 cm



A Energy Class



LED

**DESCRIPTION**

Pull-out hood with ECOPOWER motor and 5+1 speeds in 60 cm

**LIFE STYLE**

Maestro

**COLOURS**



**REFERENCE**

EAN. 8421152146248

**FEATURES**

Pull-out hood  
EcoPower motor  
Energy Efficiency class: A  
Electronic control panel  
5+1 speeds  
Exhaust capacities:  
Free Outlet, m<sup>3</sup>/h: 734  
Qboost, m<sup>3</sup>/h: 730  
Max., m<sup>3</sup>/h: 555  
Min., m<sup>3</sup>/h: 295  
Noise (LwA) Boost Speed, dB: 70,4  
Noise (LwA) Max Speed, dB: 65,3  
Noise (LwA) Min Speed, dB: 53,1  
1 LED bar  
4 stainless Steel filters MMX  
Reinforced Black Glass upper structure  
Automatic Lighting  
Exchangeable Front Panel  
Finger Print Proof Front Panel

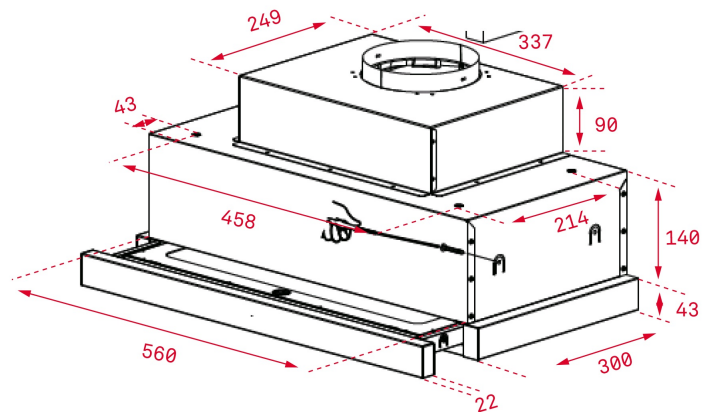

## DIMENSIONS

Product height (mm): 274

Product width (mm): 600

Product depth (mm): 300/490

Product length (mm):

Net weight (Kg): 9,63

## TECH SPECS

### PARTICULAR CHARACTERISTICS

**Type of hood:** Pull-out

**Style:** Integrated

**Certificates:** CE; CB; Rohs

**Ø Outlet (mm):** 150

**Type of inner light:** LED

**Inside light Consumption (W):** 19

**Plug type:** European plug

**Power rate (V):** 230

**Frequency (Hz):** 50

**Total hood power (W):** 274

**Number of motors:** 1

**Motor power (W):** 265

**Exhaust Capacity - Free Outlet (m<sup>3</sup>/h):** 734

**EU REGULATION NO. 65/2014  
&66/2104**

**Annual energy consumption AEC kWh/annum (kWh):** 54,5

**Energy Efficiency Class:** A

**Fluid Dynamic Efficiency (FDEhood):** 33,1

**Fluid Dynamic Efficiency class:** A

**Light Efficiency (Lehood) lux/Watt:** 43,3

**Lighting Efficiency class:** A

**Grease Filtering Efficiency class:** C  
**Air flow (Qmin) m<sup>3</sup>/h:** 295  
**Air flow (Qmax):** 555  
**Air flow (Qboost):** 730  
**Noise (LwA) Min Speed (dB):** 53  
**Noise (LwA) Max Speed (dB):** 65  
**Noise (LwA) boost speed (dB):** 70  
**Energy Efficiency Index (EEI):** 49,3  
**Time increase factor:** 0,8  
**Electric power input at best efficiency point (Wbep) W:** 164,0  
**Nominal power of the lighting system (WL) W:** 9  
**Average illumination of the lighting system on the cooking surface (Emiddle) Lux:** 390

## **ACCESSORIES**

**Anti Return valve:** Yes  
**Outlet reduction:** Yes  
**Optional Charcoal Filter:** D1C  
**Charcoal filter description:** CHARCOAL FILTER D1C

## **MODELS**

**Number of filters:** 2  
**Filter description:** Stainless Steel filters MMX  
**Control panel:** Electronic control  
**Stop delay timer:** Yes  
**Automatic lighting:** Yes  
**Number of speeds:** 5+1  
**Fingerprint proof front panel:** Yes



CNL 6815 PLUS

ENERGY LABEL

