



# CNL 6400 Pull-out hood with 2 motors and 2+1 speeds in 60 cm



Stop Delay  
Timer

**DESCRIPTION**

Pull-out hood with 2 motors and 2+1 speeds in 60 cm

**LIFE STYLE**

Easy

**COLOURS**



**REFERENCE**

EAN. 8421152146149

**FEATURES**

Pull-out hood  
Electronic control panel  
2+1 speeds  
Exhaust capacities:  
Free Outlet, m<sup>3</sup>/h: 432  
Qboost, m<sup>3</sup>/h: 385  
Max., m<sup>3</sup>/h: 224  
Min., m<sup>3</sup>/h: 161  
Noise (LwA) Boost Speed, dB: 70  
Noise (LwA) Max Speed, dB: 61  
Noise (LwA) Min Speed, dB: 56  
2 LED lamps  
2 stainless Steel filters  
Reinforced Black Glass upper structure  
Automatic Lighting  
Exchangeable Front Panel  
Finger Print Proof Front Panel (SS)

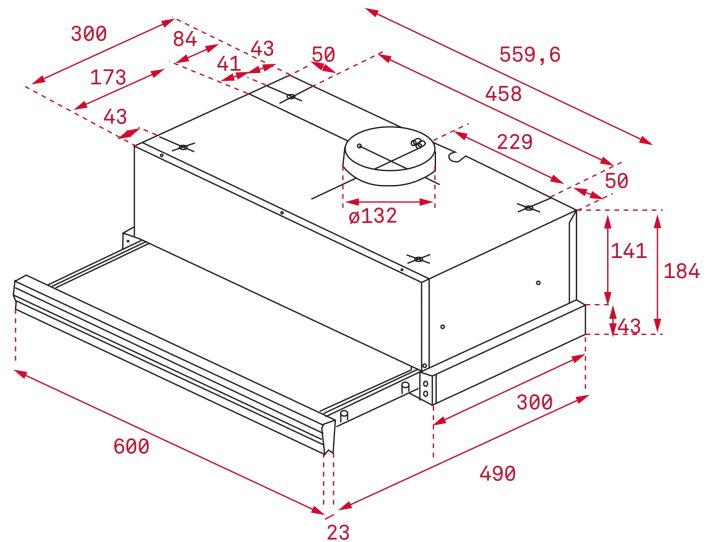

## DIMENSIONS

**Product height (mm):** 184  
**Product width (mm):** 600  
**Product depth (mm):** 300/490  
**Product length (mm):**  
**Net weight (Kg):** 9,91

## TECH SPECS

### PARTICULAR CHARACTERISTICS

**Type of hood:** Pull-out  
**Style:** Integrated  
**Certificates:** CE; CB; Rohs  
**Ø Outlet (mm):** 120  
**Type of inner light:** LED  
**Inside light Consumption (W):** 2 2  
**Plug type:** European plug  
**Power rate (V):** 230  
**Frequency (Hz):** 50  
**Total hood power (W):** 184  
**Number of motors:** 2  
**Motor power (W):** 180  
**Exhaust Capacity - Free Outlet (m3/h):** 432

**EU REGULATION NO. 65/2014  
&66/2104**

**Annual energy consumption AEC kWh/annum (kWh):** 116,5  
**Energy Efficiency Class:** D  
**Fluid Dynamic Efficiency (FDEhood):** 8,5  
**Fluid Dynamic Efficiency class:** E  
**Light Efficiency (Lehood) lux/Watt:** 28,3  
**Lighting Efficiency class:** A

**Grease Filtering Efficiency class:** D  
**Air flow (Qmin) m<sup>3</sup>/h:** 185  
**Air flow (Qmax):** 234  
**Air flow (Qboost):** 358  
**Noise (LwA) Min Speed (dB):** 56  
**Noise (LwA) Max Speed (dB):** 61  
**Noise (LwA) boost speed (dB):** 70  
**Energy Efficiency Index (EEI):** 98,6  
**Time increase factor:** 1,7  
**Electric power input at best efficiency point (Wbep) W:** 183,0  
**Nominal power of the lighting system (WL) W:** 4  
**Average illumination of the lighting system on the cooking surface (Emiddle) Lux:** 113

## **ACCESSORIES**

**Anti Return valve:** Yes  
**Outlet extension:** yes  
**Optional Charcoal Filter:** C1C  
**Charcoal filter description:** CHARCOAL FILTER C1C

## **MODELS**

**Number of filters:** 2  
**Filter description:** Stainless Steel filters  
**Control panel:** Electronic control  
**Stop delay timer:** Yes  
**Automatic lighting:** Yes  
**Number of speeds:** 2+1  
**Fingerprint proof front panel:** Yes



CNL 6400

ENERGY LABEL

